

RESEARCH IN MOTION CONFIDENTIAL

<b>HIERARCHICAL BLOCK</b> MAIN <b>DRAWN BY</b> A. Roemer <b>R&amp;G CHECK</b> <b>FIG CHECK</b>	COPYRIGHT 2010, RESEARCH IN MOTION LIMITED 295 PHILLIP ST. WATERLOO, ONTARIO, CANADA PHONE: (519) 888-7465, FAX (519) 888-6306
	<b>TITLE</b> R020 (Band I, II, V, VI) <small>(Uses: PCB-31441-002)</small>
<b>Edi Led Bu:</b> aroemer <small>Level Ed1: Jul 14, 2010, 2:55:16 pm</small>	<b>SIZE</b> (Uses: PCB-31441-002) <b>DRAWING NO.</b> SCH-31442-002
<b>REV</b> 1 <b>SHEET</b> 1 OF 19	

RF\_ANT

LAYOUT: ANT clips position DOUBLE check orientation

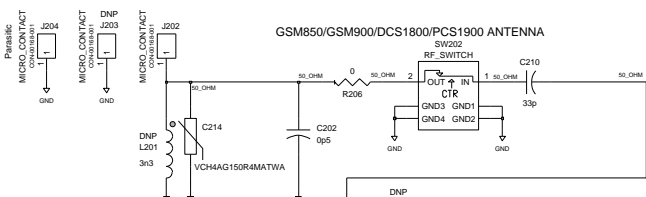

GSM850/GSM900/DCS1800/PCS1900 ANTENNA

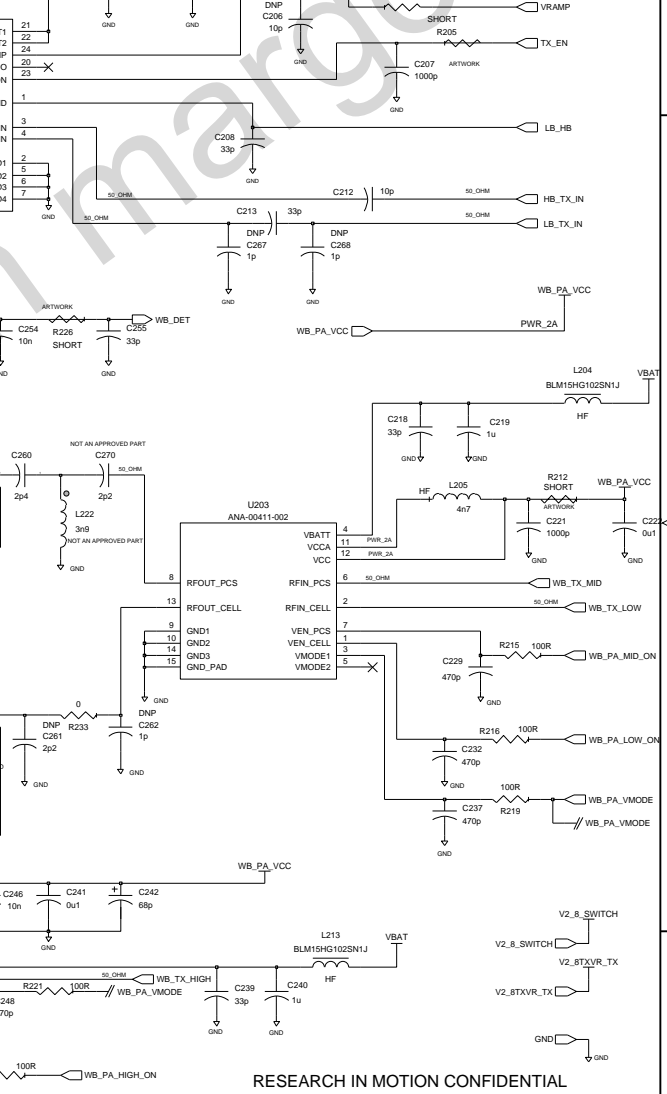
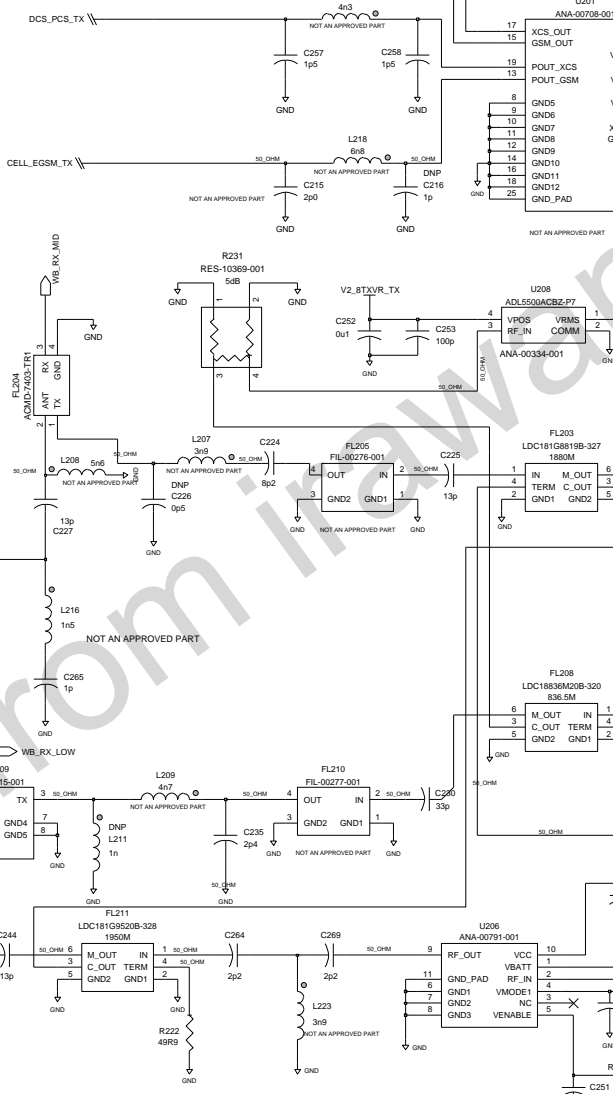
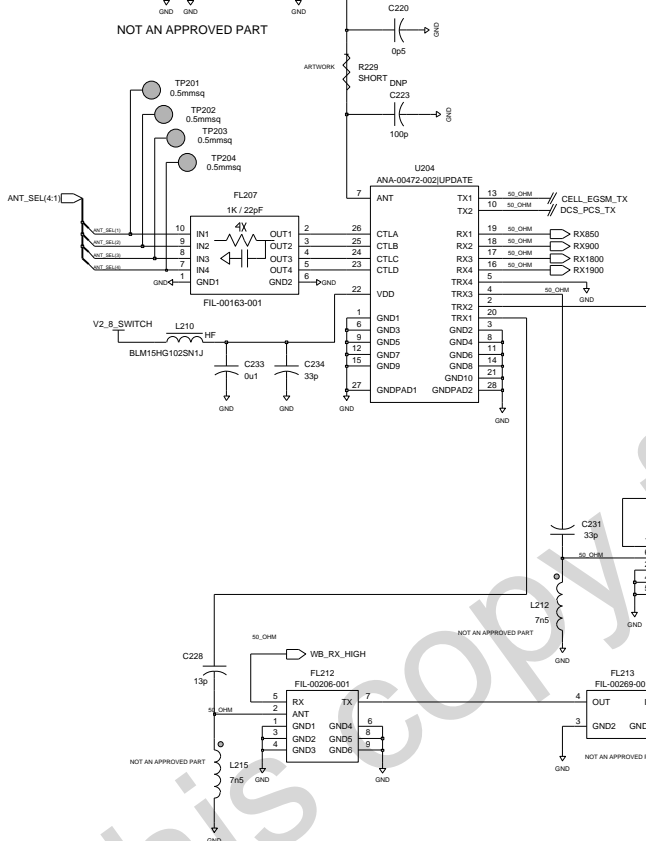

RESEARCH IN MOTION CONFIDENTIAL

HIERARCHICAL BLOCK RF_ANT		COPYRIGHT 2010, RESEARCH IN MOTION LIMITED 295 PHILLIP ST. WATERLOO, ONTARIO, CANADA PHONE: (519) 888-7465, FAX (519) 888-6306	
DRAWN BY A. Roemer		TITLE R020 (Band I, II, V, VI) (uses: PCB-31444-002)	
R&D CHECK		SIZE DRAWING No. SCH-31444-002	
MFG CHECK		C REV 1	
Edi Led By: aroemer		SHEET 2 OF 19	
Last Ed: Jul 13, 2010, 8:44:48 am			

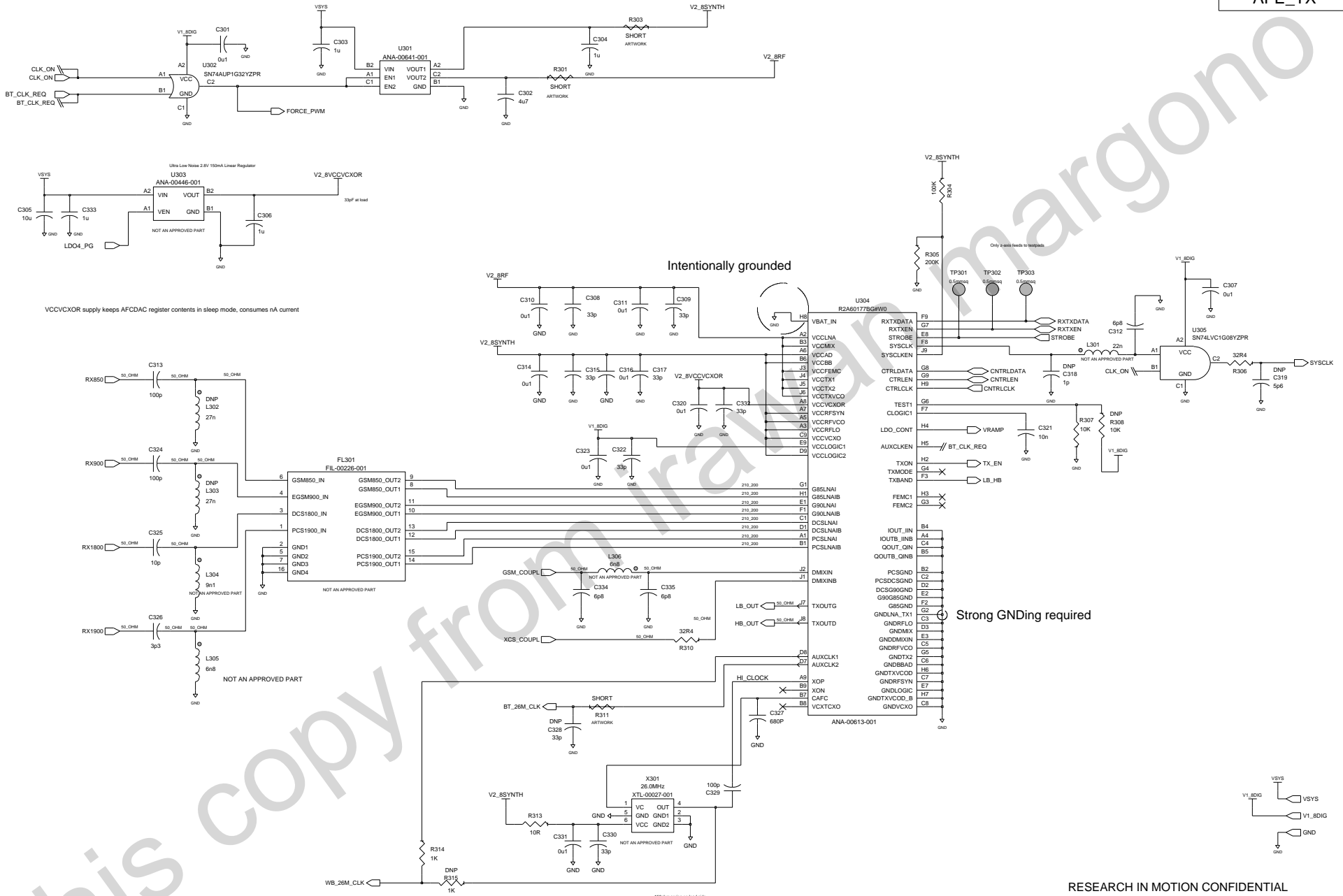

Strong GNDing required

RESEARCH IN MOTION CONFIDENTIAL

HIERARCHICAL BLOCK AFE_TX	COPYRIGHT 2010, RESEARCH IN MOTION LIMITED 295 PHILLIP ST. WATERLOO, ONTARIO, CANADA PHONE: (519) 888-7465, FAX (519) 888-6306
DRAWN BY: A. Roemer	TITLE R020 (Band I, II, V, VI)
R&D CHECK	(uses: PCB-31441-002)
MFG CHECK	SIZE DRAWING No. SCH-31442-002
Edi Led By: aroemer	C REV 1 SHEET 3 OF 19
Label: Ed1: May 27, 2010, 8:46:09 am	

WB\_AFE

D

D

C

C

B

B

A

A

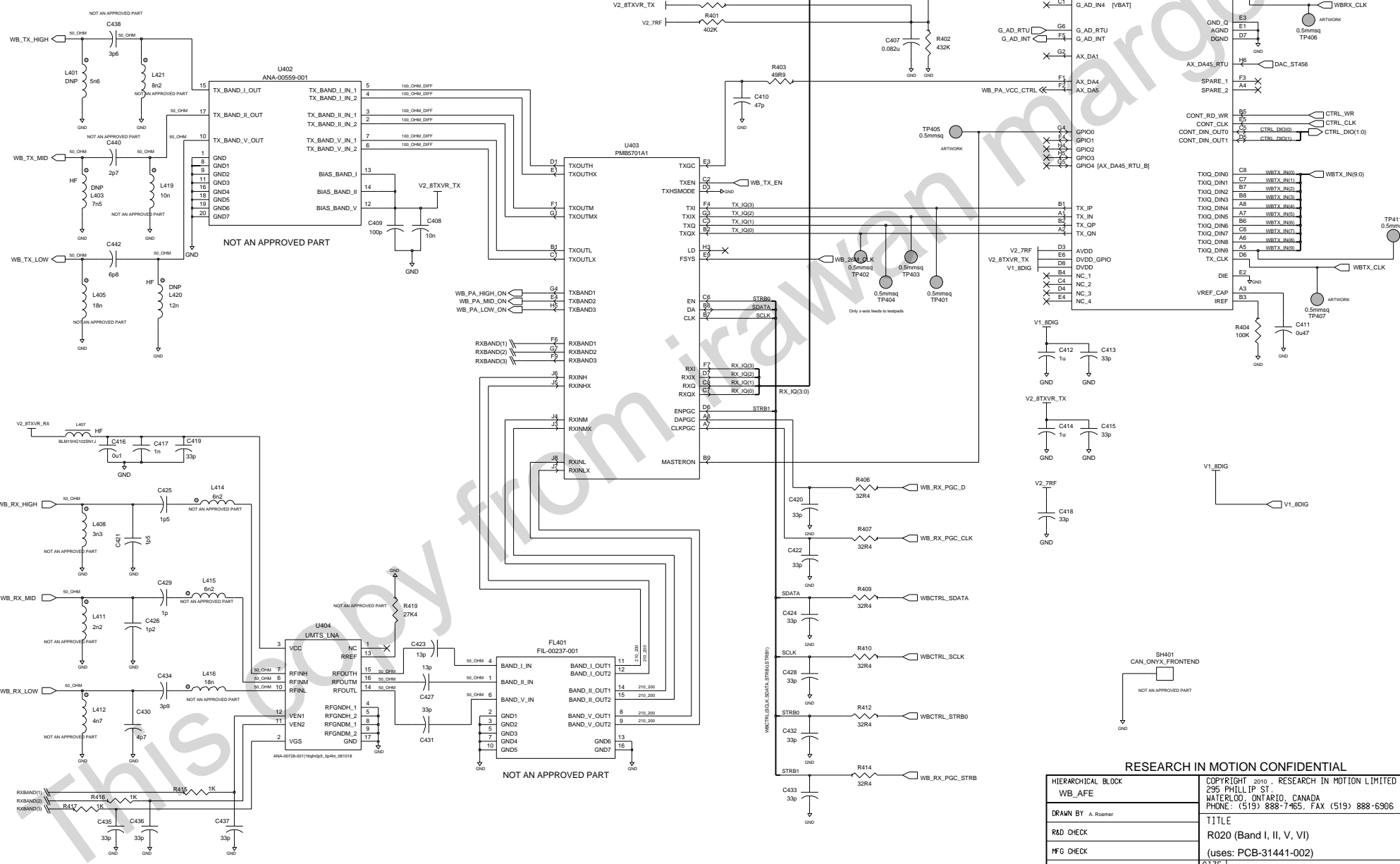

RESEARCH IN MOTION CONFIDENTIAL

HIERARCHICAL BLOCK WB_AFE	COPYRIGHT 2010, RESEARCH IN MOTION LIMITED 295 PHILLIP ST. WATERLOO, ONTARIO, CANADA PHONE: (519) 888-7465, FAX (519) 888-6306
DRAWN BY: A. Roemer	TITLE R020 (Band I, II, V, VI)
R&D CHECK	(uses: PCB-31441-002)
MFG CHECK	SIZE DRAWING No. SCH-31442-002
Edi Led Bu: aroemer	C REV 1 SHEET 4 OF 19
Level: Ed1:1 May 27, 2010, 9:01:25 am	

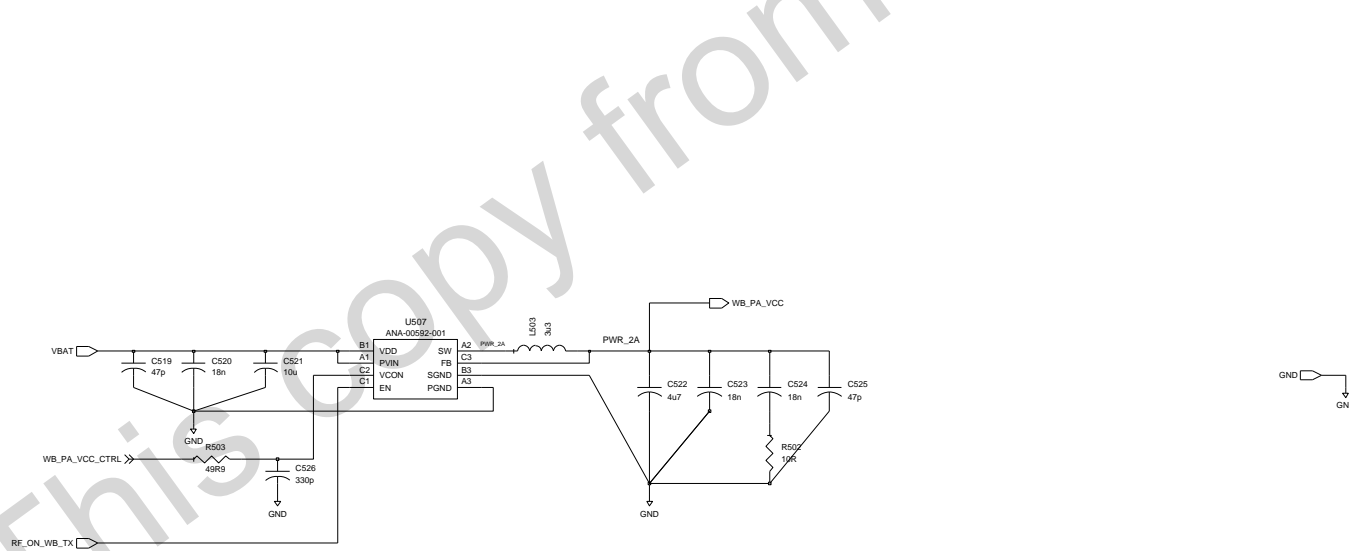
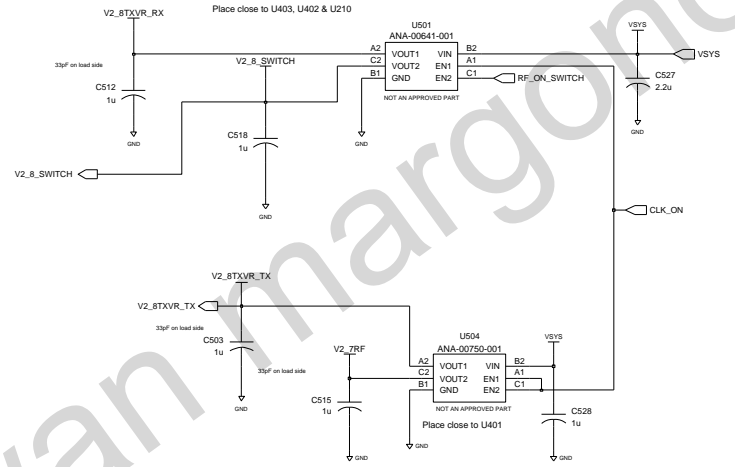
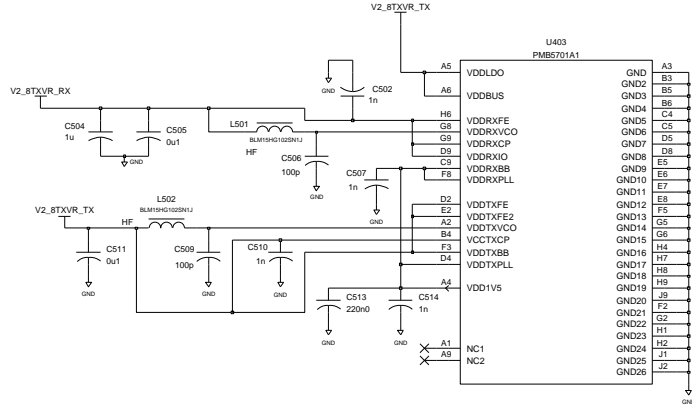

RESEARCH IN MOTION CONFIDENTIAL

HIERARCHICAL BLOCK WB_AFE2	COPYRIGHT 2009, RESEARCH IN MOTION LIMITED 295 PHILLIP ST. WATERLOO, ONTARIO, CANADA PHONE: (519) 888-7465, FAX (519) 888-6306
DRAWN BY A. Roemer	TITLE R020 (Band I, II, V, VI)
R&D CHECK	(uses: PCB-31441-002)
MFG CHECK	SIZE DRAWING No. SCH-31442-002
Ed: Led Bu: gkug	C REV 1 SHEET 5 OF 19
Level: Ed: 1: Jun 2, 2009, 9:49:50 am	

A-GPS

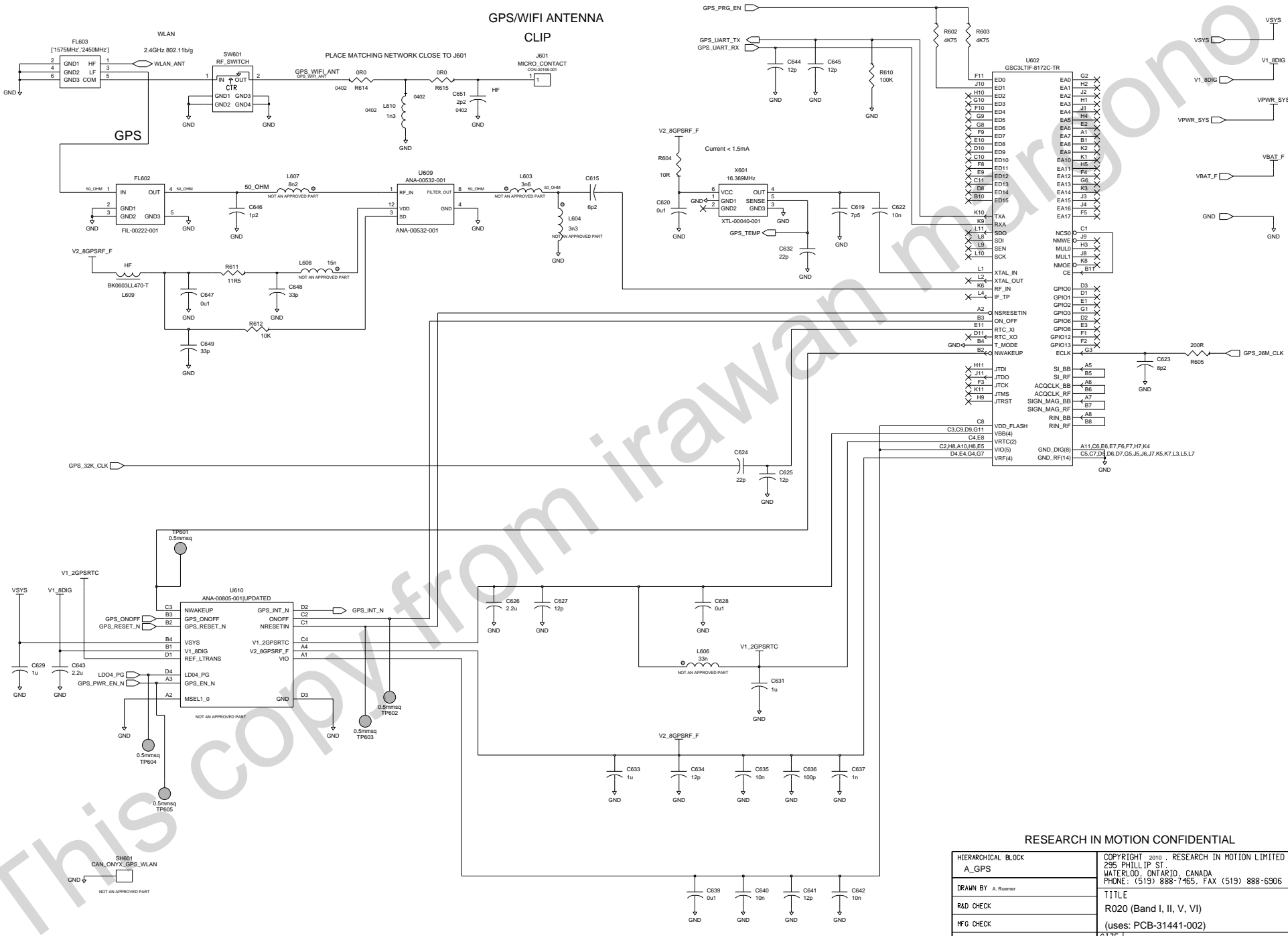

RESEARCH IN MOTION CONFIDENTIAL

HIERARCHICAL BLOCK A_GPS		COPYRIGHT 2010, RESEARCH IN MOTION LIMITED 295 PHILLIP ST. WATERLOO, ONTARIO, CANADA PHONE: (519) 888-7465, FAX (519) 888-6306	
DRAWN BY: A. Roemer		TITLE R020 (Band I, II, V, VI) (uses: PCB-31441-002)	
R&D CHECK		SIZE DRAWING No. SCH-31442-002	
MFG CHECK		REV 1 SHEET 6 OF 19	
Edi Led Bu: aroemer		C	
Last Ed1: May 27, 2010, 9:44:50 am			

D

D

C

C

B

B

A

A

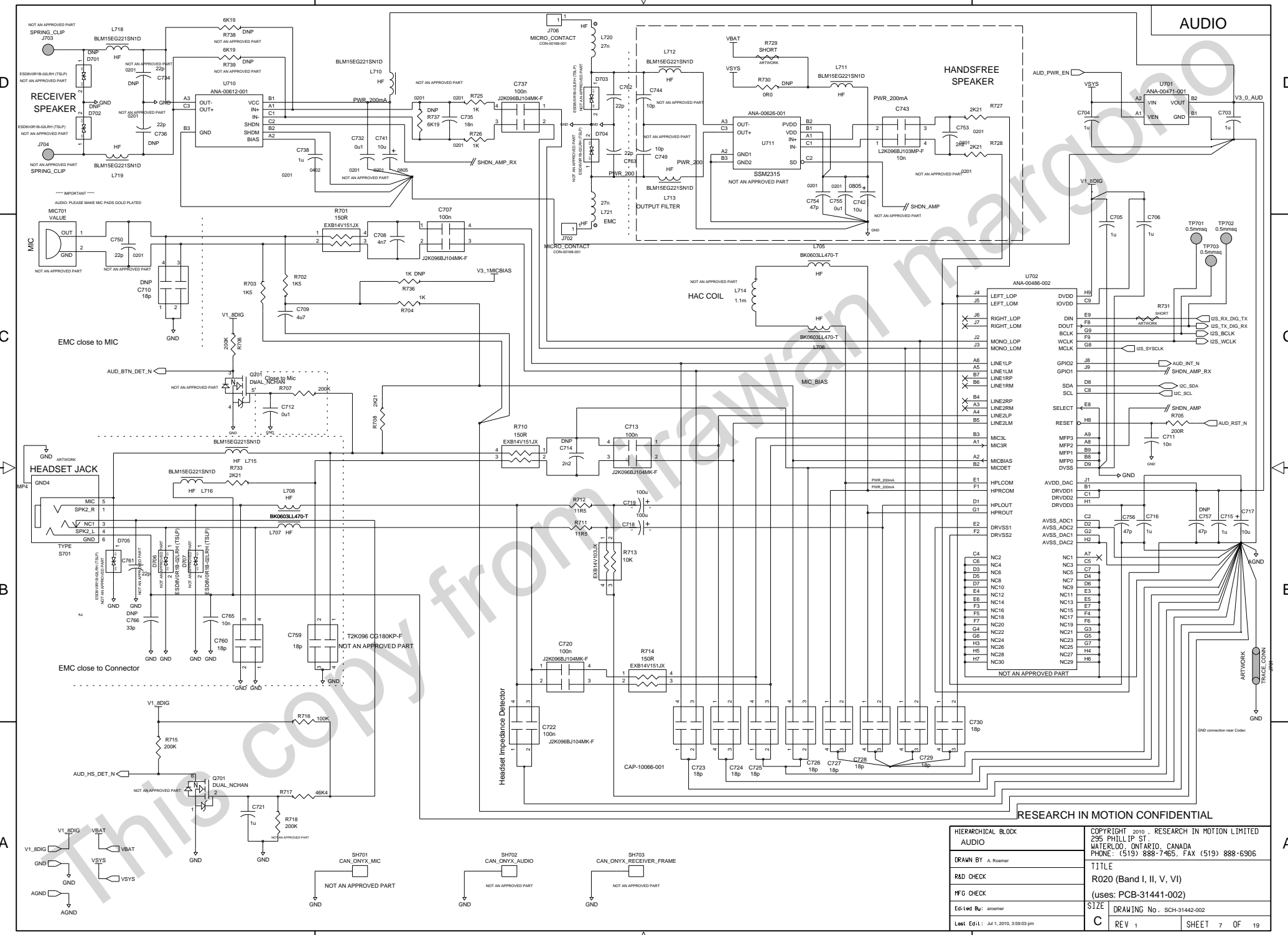

RESEARCH IN MOTION CONFIDENTIAL

HIERARCHICAL BLOCK AUDIO		COPYRIGHT 2010, RESEARCH IN MOTION LIMITED WATERLOO, ONTARIO, CANADA PHONE: (519) 888-7465, FAX (519) 888-6306	
DRAWN BY: A. Roemer		TITLE R020 (Band I, II, V, VI) (uses: PCB-31441-002)	
R&D CHECK		SIZE C	
MFG CHECK		DRAWING No. SCH-31442-002	
Edi Led By: arsemer		REV 1	
Last Ed: 1 Jul 1, 2010, 3:59:03 pm		SHEET 7 OF 19	

D  
C  
B  
A

4 3 2 1

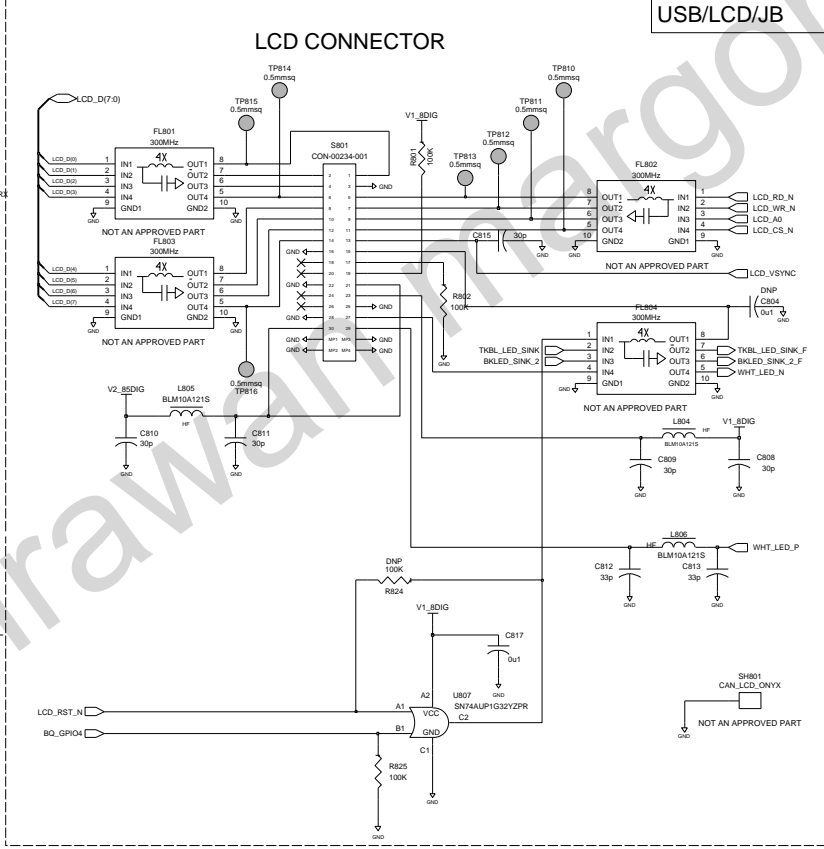
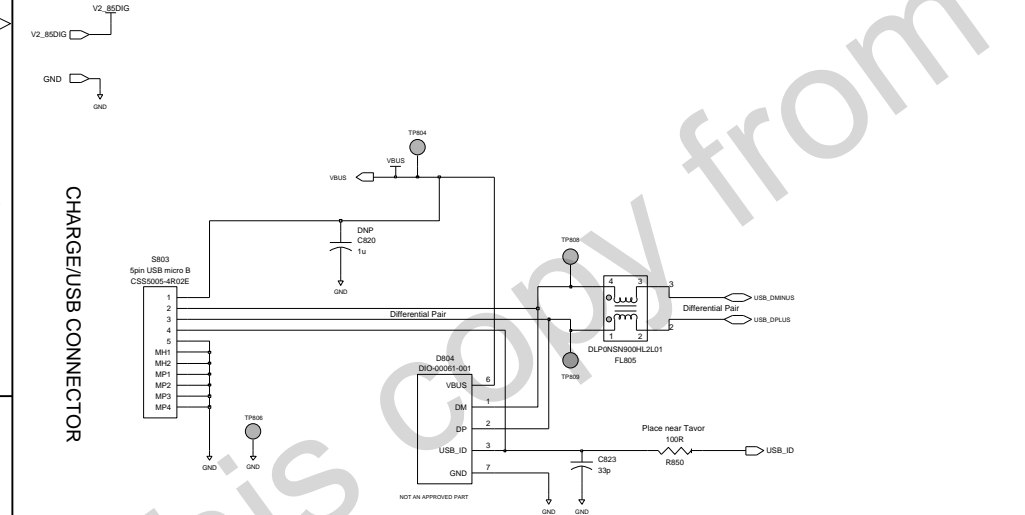
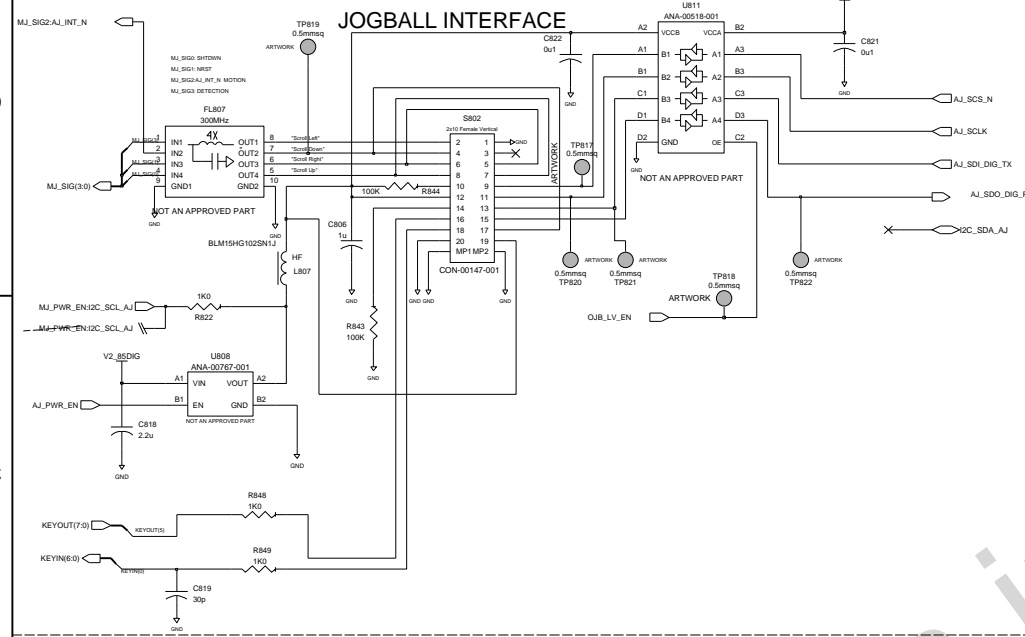

RESEARCH IN MOTION CONFIDENTIAL

HIERARCHICAL BLOCK JOINTERFACE	COPYRIGHT 2010, RESEARCH IN MOTION LIMITED 295 PHILLIP ST. WATERLOO, ONTARIO, CANADA PHONE: (519) 888-7455, FAX (519) 888-6906
DRAWN BY: A. Roemer	TITLE R020 (Band I, II, V, VI) (uses: PCB-31441-002)
R&D CHECK	SIZE DRAWING No. : S2H-31443-002
MFG CHECK	C REV 1 SHEET 8 OF 18
Edited By: unswmer	
Last Edit: May 6, 2010, 4:49:25 pm	



POWER

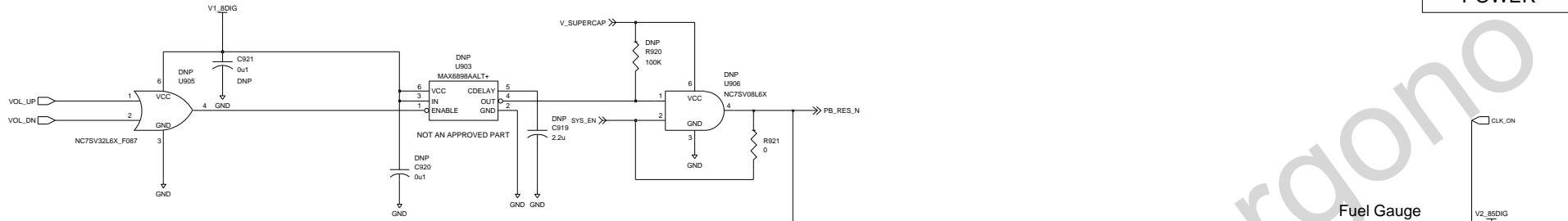

Push Button Reset

This circuit needs to be DNPed for externally released units

To remove: DNP U905, C921, C920, U903, C919, R920, U906

Populate: R921

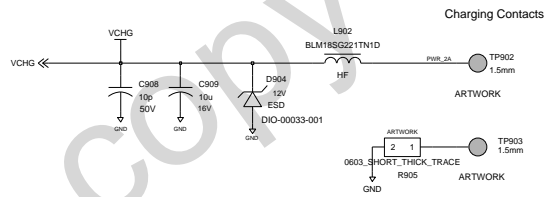
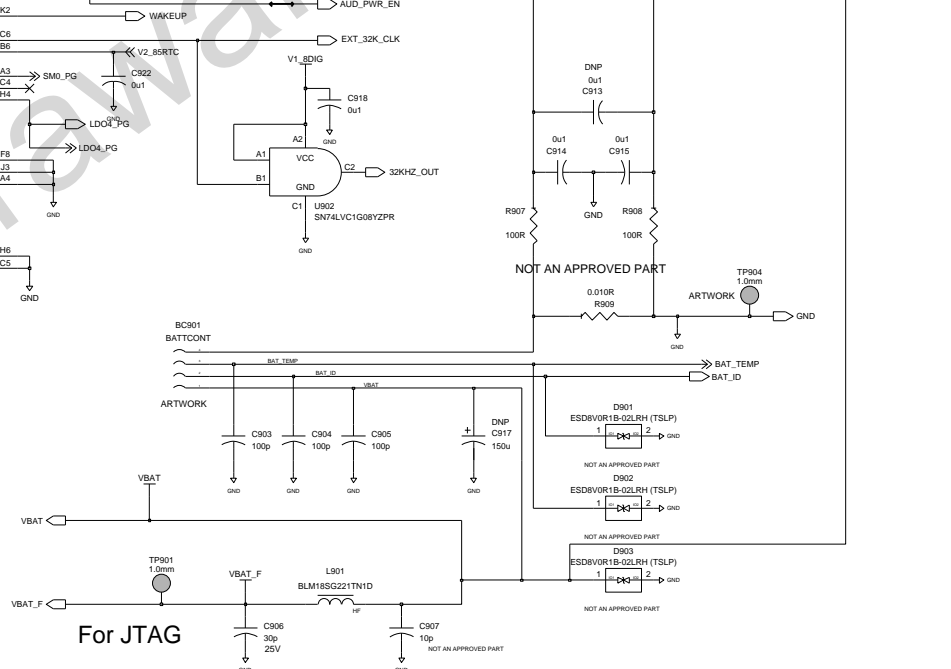
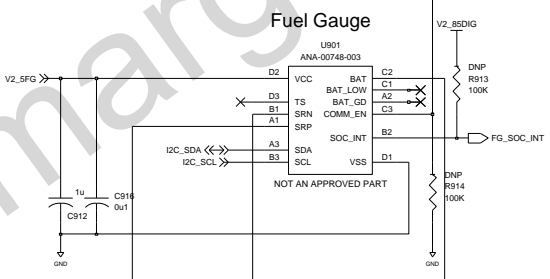
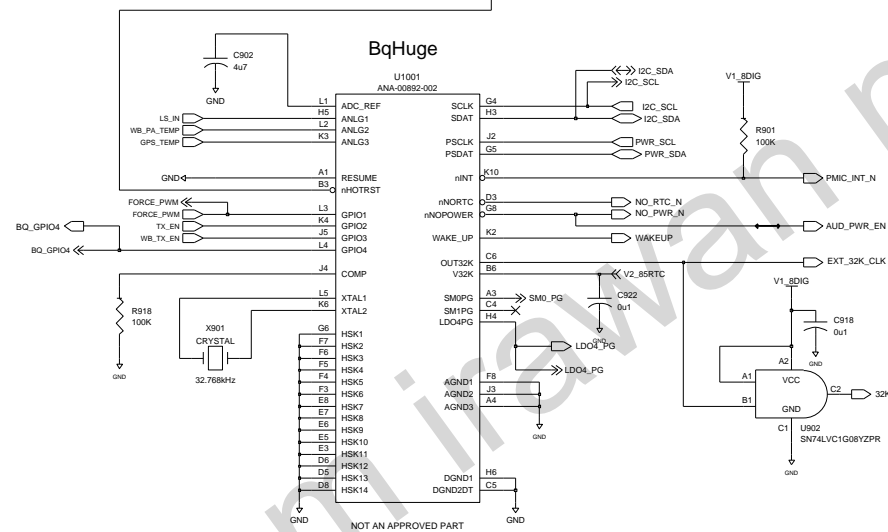

For JTAG

RESEARCH IN MOTION CONFIDENTIAL

HIERARCHICAL BLOCK POWER22	COPYRIGHT 2010, RESEARCH IN MOTION LIMITED 295 PHILLIP ST. WATERLOO, ONTARIO, CANADA PHONE: (519) 888-7465, FAX (519) 888-6306
DRAWN BY A. Roemer	TITLE R020 (Band I, II, V, VI)
R&D CHECK	(uses: PCB-31441-002)
MFG CHECK	SIZE DRAWING No. SCH-31442-002
Ed: Led Bu: gkug	C REV 1 SHEET 9 OF 19
Label Ed1: Feb-25, 2010, 1:58:40 pm	

COPIED FROM METEOR REV 005-1B  
UPDATED FROM JAVELIN REV005A

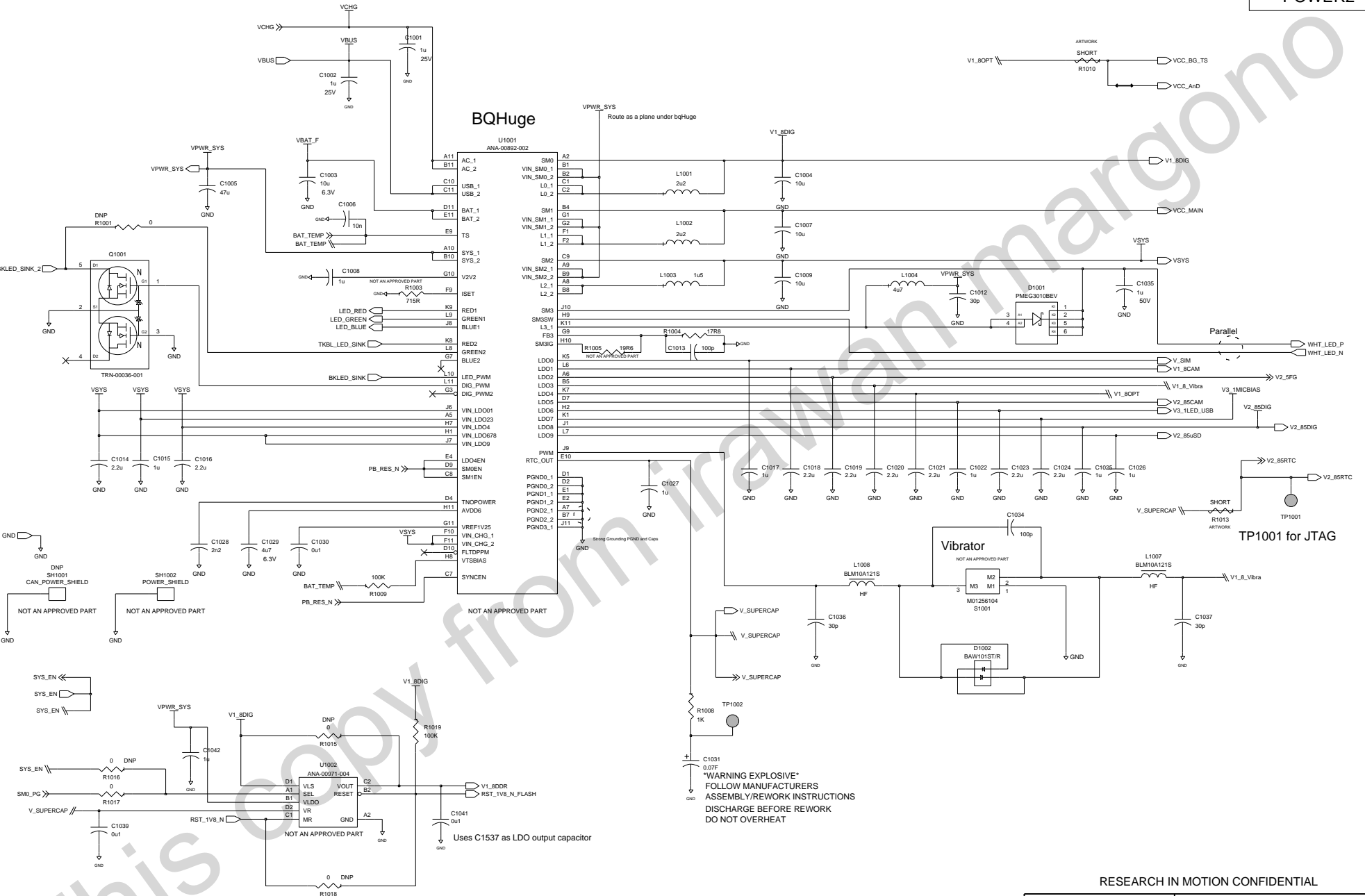

RESEARCH IN MOTION CONFIDENTIAL

HIERARCHICAL BLOCK POWER2		COPYRIGHT 2010, RESEARCH IN MOTION LIMITED 295 PHILLIP ST. WATERLOO, ONTARIO, CANADA PHONE: (519) 888-7465, FAX (519) 888-6306	
DRAWN BY A. Roemer		TITLE R020 (Band I, II, V, VI)	
R&D CHECK		(uses: PCB-31441-002)	
MFG CHECK		SIZE DRAWING No. SCH-31442-002	
Edi Led Bu: aroemer		C	
Label Ed1: Jul 1, 2010, 10:34:34 am		REV 1	SHEET 10 OF 19

4

3

2

1

SIM

### SIM CONNECTOR

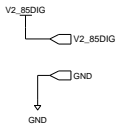
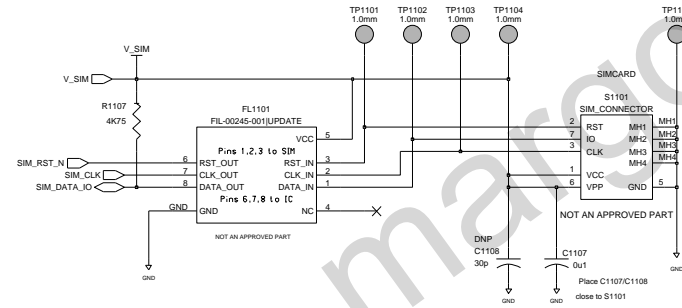

RESEARCH IN MOTION CONFIDENTIAL

HIERARCHICAL BLOCK KEYBRD		COPYRIGHT 2010, RESEARCH IN MOTION LIMITED 295 PHILLIP ST. WATERLOO, ONTARIO, CANADA PHONE: (519) 888-7465, FAX (519) 888-6306	
DRAWN BY: A. Roemer		TITLE R020 (Band I, II, V, VI) (uses: PCB-31441-002)	
R&D CHECK		SIZE DRAWING No. SCH-31442-002	
MFG CHECK		C	
Ed: Led Bu: gkug		REV 1 SHEET 11 OF 19	
Level: Ed1: Mar 2, 2010, 7:54:43 am			

4

3

2

1

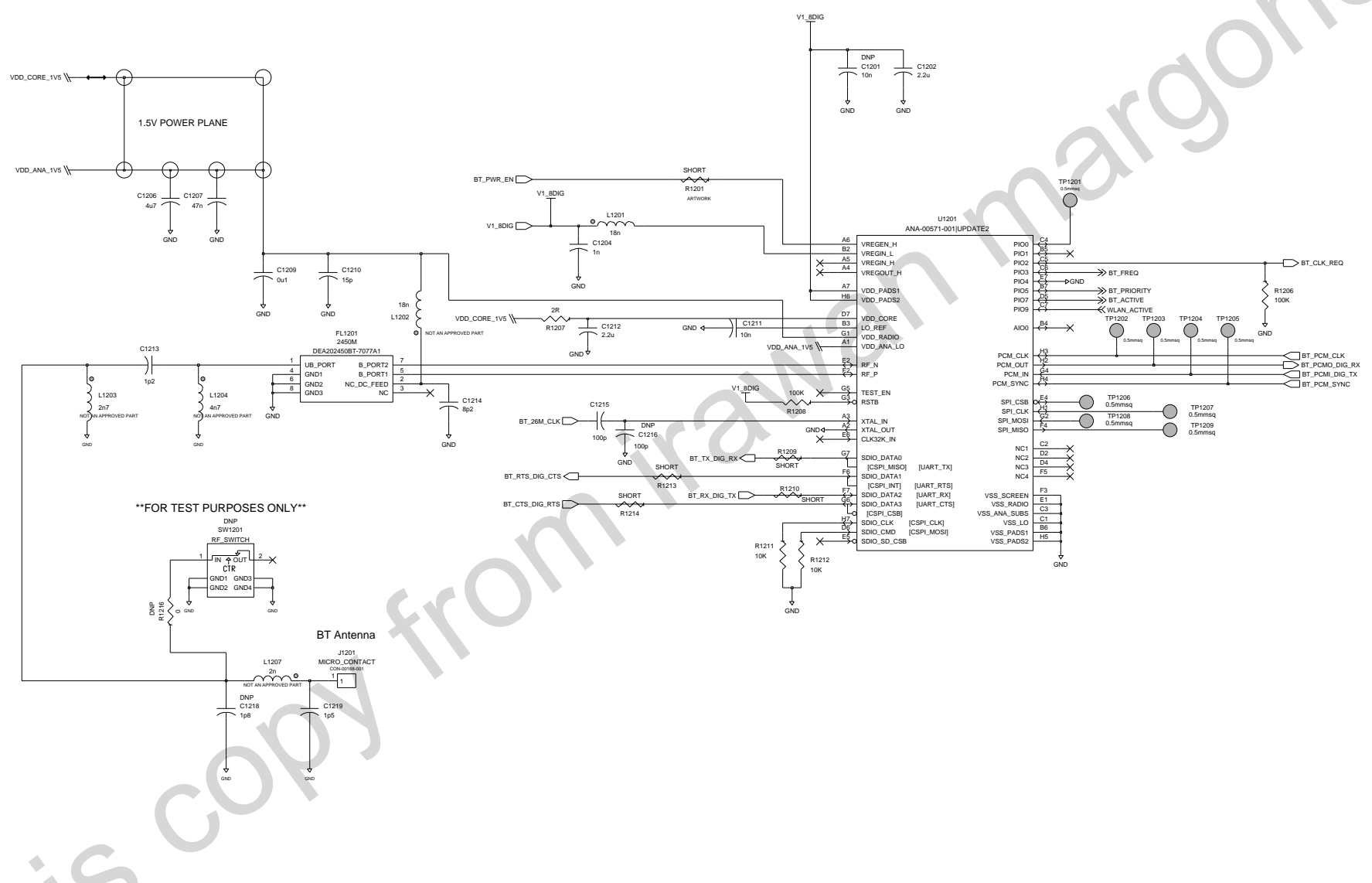

\*\*FOR TEST PURPOSES ONLY\*\*

RESEARCH IN MOTION CONFIDENTIAL

HIERARCHICAL BLOCK BT_WLAN		COPYRIGHT 2010, RESEARCH IN MOTION LIMITED 295 PHILLIP ST. WATERLOO, ONTARIO, CANADA PHONE: (519) 888-7465, FAX (519) 888-6306	
DRAWN BY: A. Roemer		TITLE R020 (Band I, II, V, VI)	
R&D CHECK		(uses: PCB-31441-002)	
MFG CHECK		SIZE DRAWING No. SCH-31442-002	
Edi Led Bu: aroemer		C REV 1 SHEET 12 OF 19	
Level Edi1: May 27, 2010, 9:50:55 am			

UPDATED WITH CHANGES FROM JAVELIN REV 5A

UMTS RADIO

RF U1301  
88CP940-C1NBHK2C624TVUS

UMTS  
(V1\_300G)

EDGE  
(V1\_300G)

NOT AN APPROVED PART

GPIO U1301  
88CP940-C1NBHK2C624TVUS

NOT AN APPROVED PART

RESEARCH IN MOTION CONFIDENTIAL

HIERARCHICAL BLOCK PROCESSOR	COPYRIGHT © 2010, RESEARCH IN MOTION LIMITED 295 PHILLIP ST. WATERLOO, ONTARIO, CANADA PHONE: (519) 888-7465, FAX (519) 888-6306
DRAWN BY A. Roemer	
R&D CHECK	
IFG CHECK	TITLE R020 (Band I, II, V, VI) (uses: PCB-31441-002)
Edi Led Bu: aroemer	SIZE DRAWING No. SCH-31442-002
Label Ed1: Apr 21, 2010, 2:12:53 pm	C REV 1 SHEET 13 OF 19

Camera test points to be placed under LCD

D

D

C

C

B

B

A

A

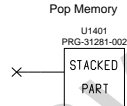
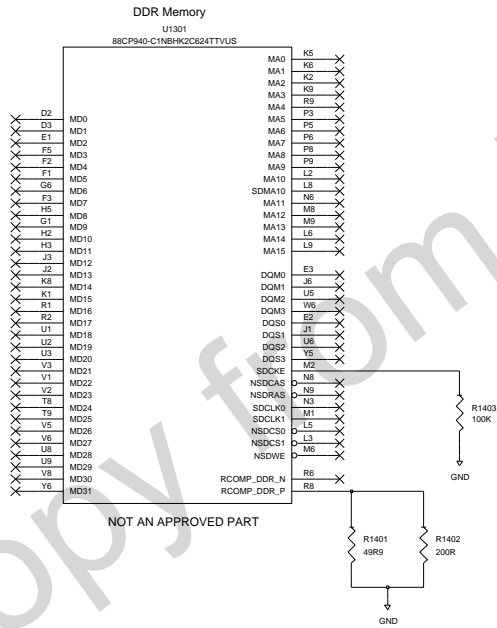
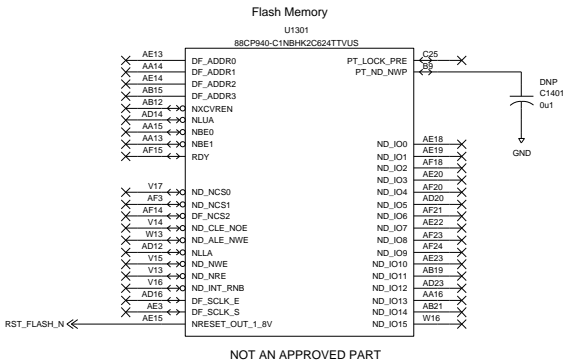

RESEARCH IN MOTION CONFIDENTIAL

HIERARCHICAL BLOCK PROCESSOR2		COPYRIGHT 2010, RESEARCH IN MOTION LIMITED 295 PHILLIP ST. WATERLOO, ONTARIO, CANADA PHONE: (519) 888-7465, FAX (519) 888-6306	
DRAWN BY A. Roemer		TITLE R020 (Band I, II, V, VI)	
R&D CHECK		(uses: PCB-31441-002)	
MFG CHECK		SIZE DRAWING No. SCH-31442-002	
Edt Led By: aroemer		C REV 1 SHEET 14 OF 19	
Last Edt: Apr 20, 2010, 11:09:10 am			

D

D

C

C

B

B

A

A

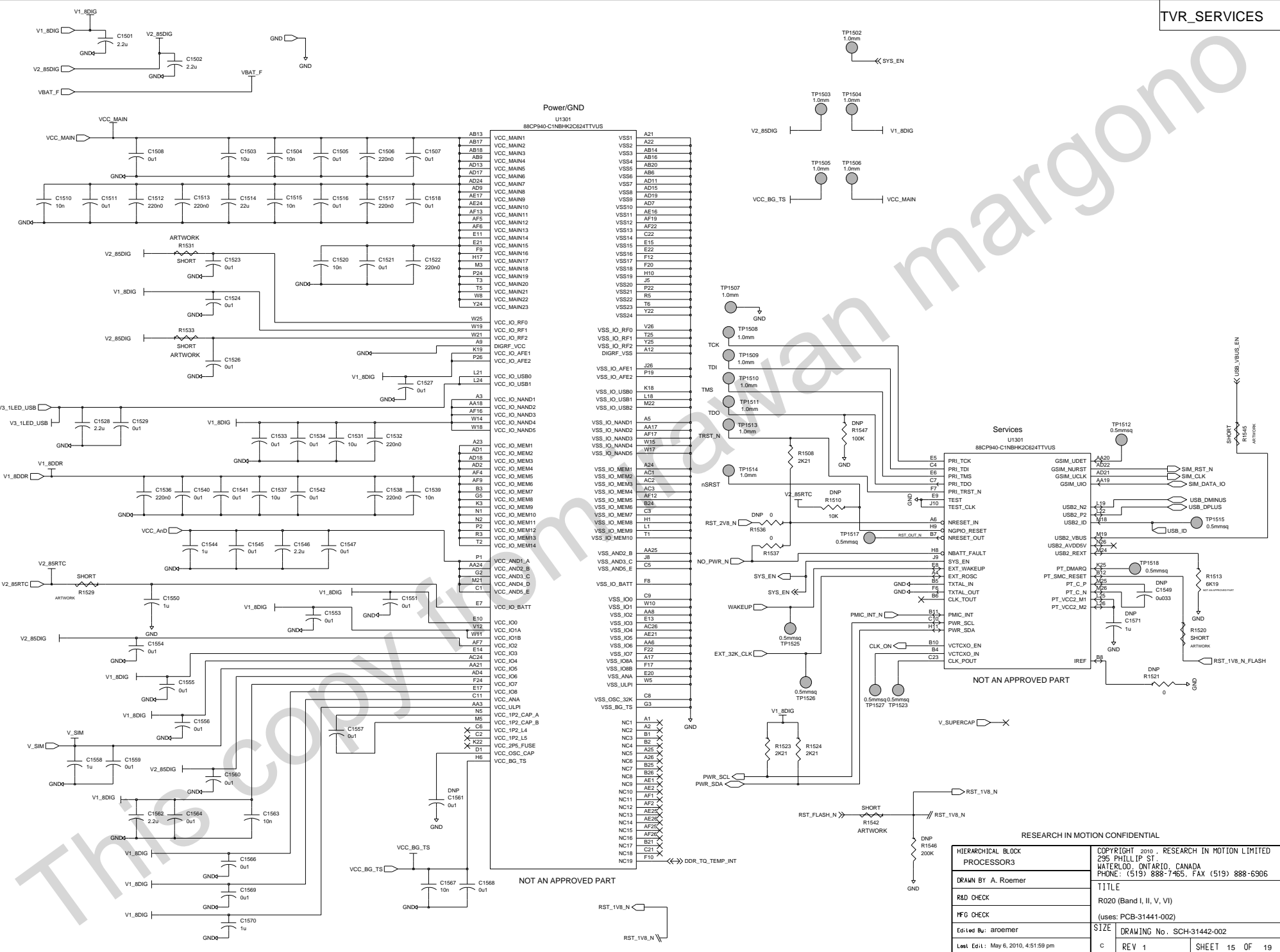

HIERARCHICAL BLOCK PROCESSOR3		COPYRIGHT 2010, RESEARCH IN MOTION LIMITED 295 PHILLIP ST. WATERLOO, ONTARIO, CANADA PHONE: (519) 888-7465, FAX (519) 888-6306	
DRAWN BY: A. Roemer		TITLE R020 (Band I, II, V, VI)	
R&D CHECK		(uses: PCB-31441-002)	
MFG CHECK		SIZE DRAWING No. SCH-31442-002	
Edi Led By: aroemer		C REV 1	
Last Ed1: May 6, 2010, 4:51:59 pm		SHEET 15 OF 19	

TRI-COLOR LED

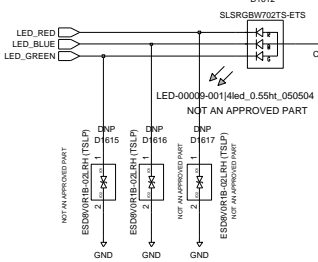

LIGHT SENSOR

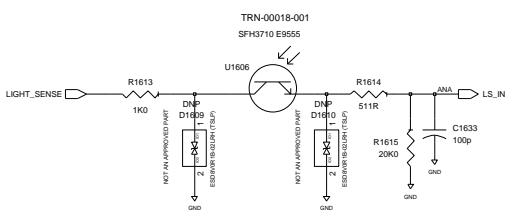

CAMERA FLASH

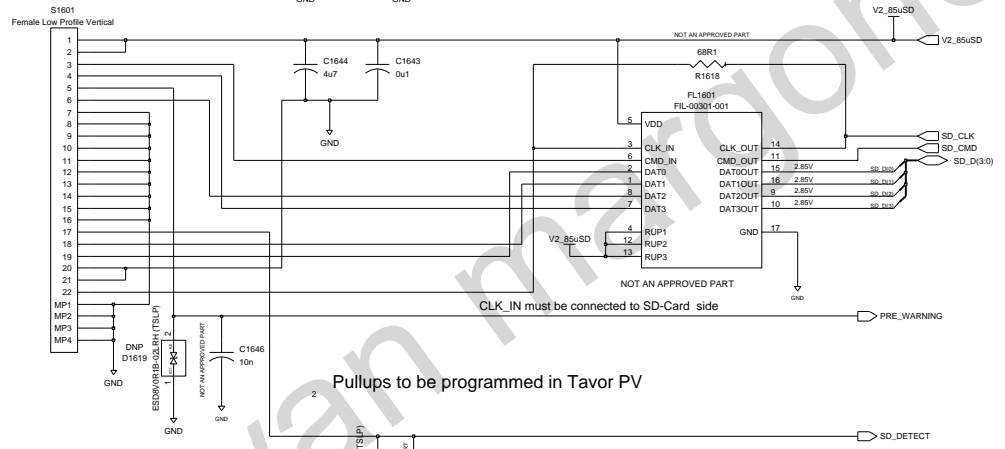
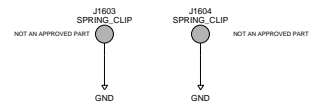
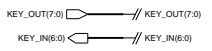
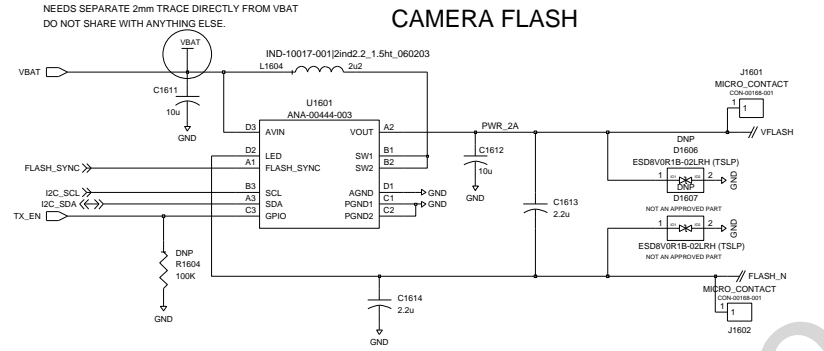

Pullups to be programmed in Tavor PV

CLK\_IN must be connected to SD-Card side

RESEARCH IN MOTION CONFIDENTIAL

HIERARCHICAL BLOCK JOINTERFACE2	COPYRIGHT 2010, RESEARCH IN MOTION LIMITED 295 PHILLIP ST. WATERLOO, ONTARIO, CANADA PHONE: (519) 888-7465, FAX (519) 888-6306
DRAWN BY A. Roemer	TITLE R020 (Band I, II, V, VI)
R&D CHECK	(uses: PCB-31441-002)
MFG CHECK	SIZE DRAWING No. SCH-31442-002
Edi Led Bu: gklug	C REV 1 SHEET 16 OF 19
Level: Edi14: Jan 25, 2010, 1:22:05 pm	



Z-axis connection only  
Place close to Digital side  
Route SMD lines as a bus, min trans

**MAC BB**

U1701  
WL1251BZQZR

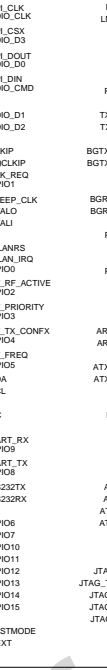

**.11b/g FEM**

U1702  
WL1251FEBSR

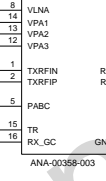

**WLAN**

2.4GHz 802.11b/g

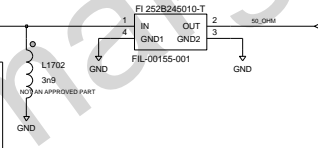

**MAC BB**

U1701  
WL1251BZQZR

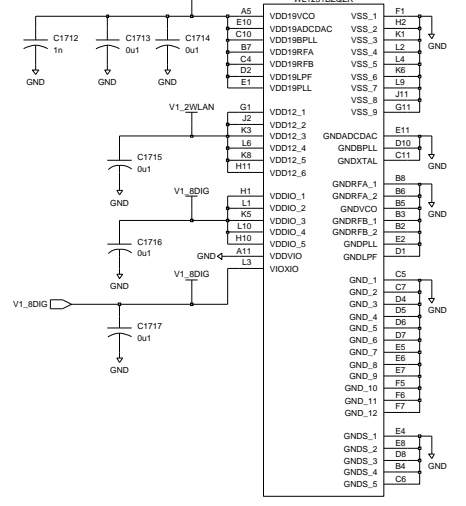

**WLAN\_PMIC**

U1706  
WL1251PMBZRKR

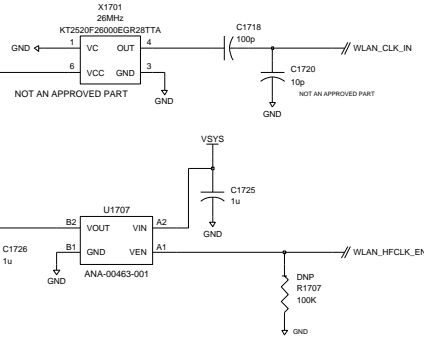
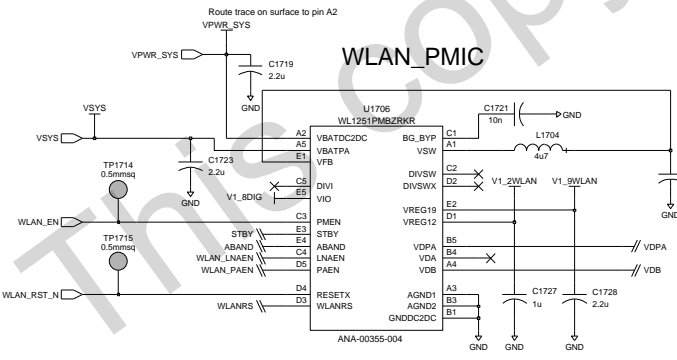

**RESEARCH IN MOTION CONFIDENTIAL**

HIERARCHICAL BLOCK BT_WLAN2		COPYRIGHT 2010, RESEARCH IN MOTION LIMITED 295 PHILLIP ST. WATERLOO, ONTARIO, CANADA PHONE: (519) 888-7465, FAX (519) 888-6306	
DRAWN BY: A. Roemer		TITLE R020 (Band I, II, V, VI) (uses: PCB-31441-002)	
R&D CHECK		SIZE DRAWING No. SCH-31442-002	
HFG CHECK		C REV 1 SHEET 17 OF 19	
Ed: Led Bu: aroemer Last Ed: 1 May 27, 2010, 9:52:47 am			

UPDATED WITH CHANGES FROM JAVELIN REV 5A

Keyboard

Mute

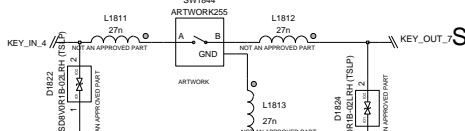

Lock

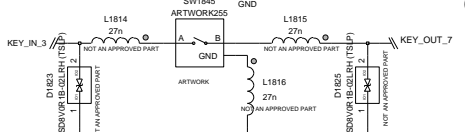

Volume Keys

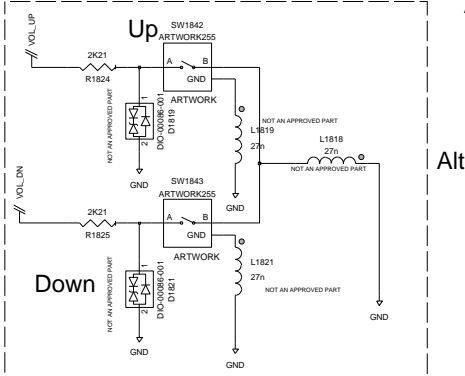

Shift Left

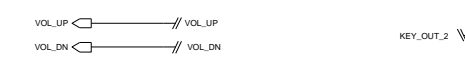

KEYBOARD

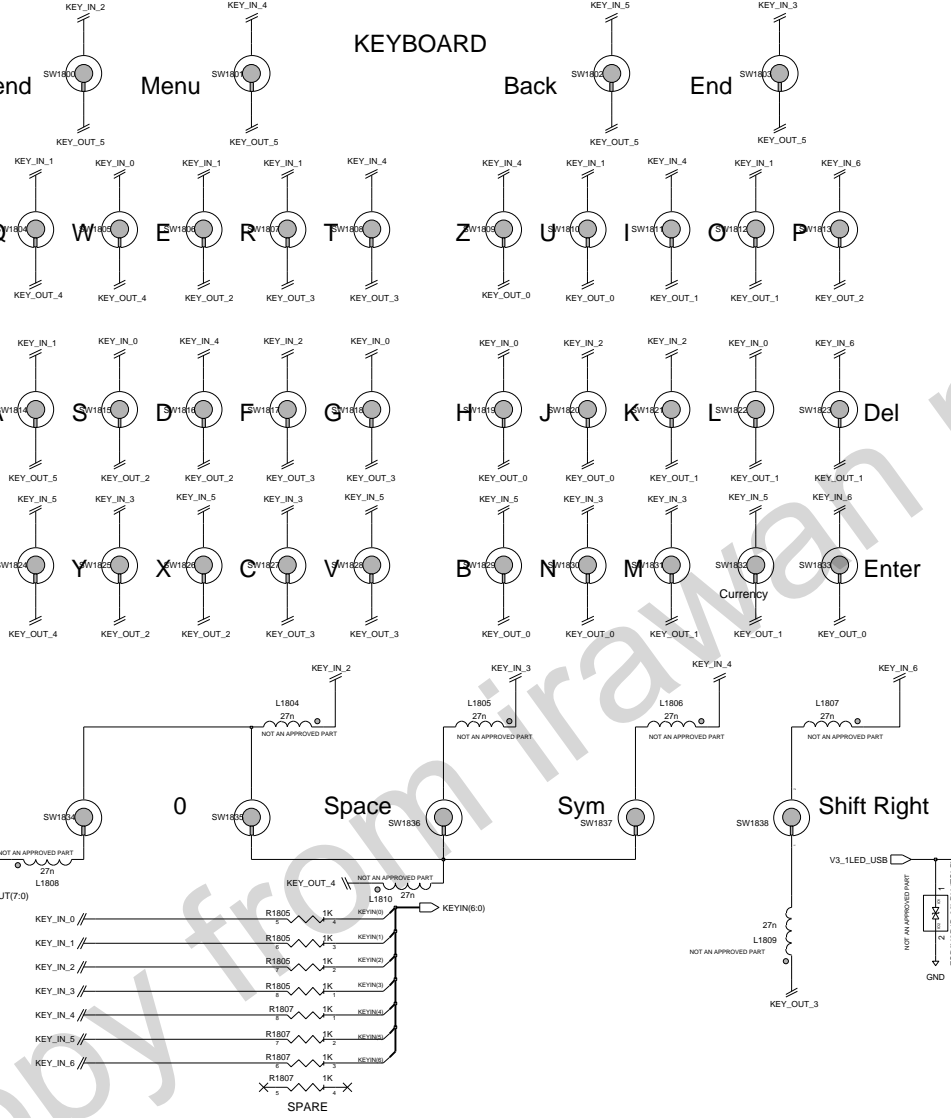

WHITE LEDS

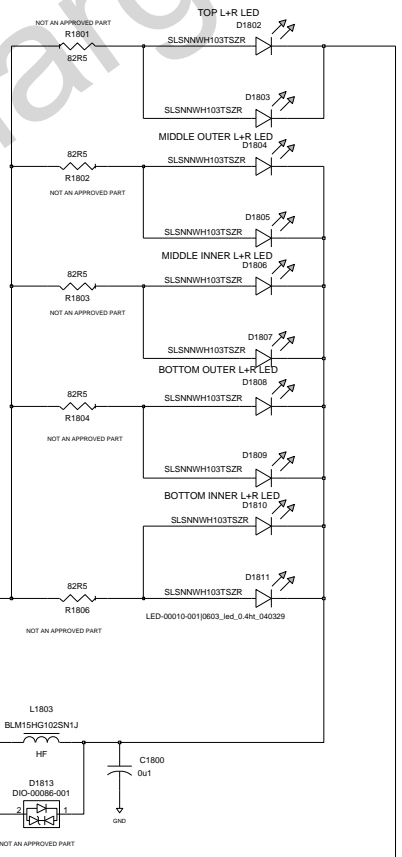

D

D

C

C

B

B

A

A

SIDE KEYS

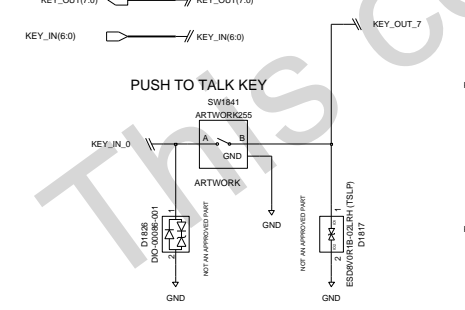

CAMERA SHUTTER

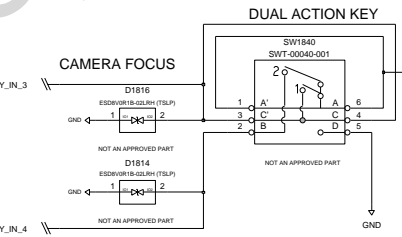

PROXIMITY SENSOR

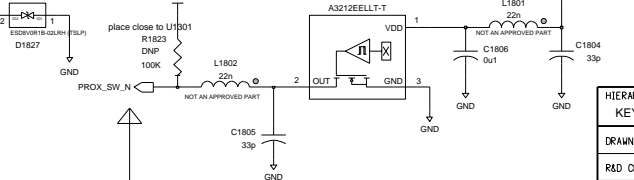

RESEARCH IN MOTION CONFIDENTIAL

HIERARCHICAL BLOCK KEYBRD2	COPYRIGHT 2010, RESEARCH IN MOTION LIMITED 295 PHILLIP ST. WATERLOO, ONTARIO, CANADA PHONE: (519) 888-7465, FAX (519) 888-6306
DRAWN BY: A. Roemer	TITLE R020 (Band I, II, V, VI)
R&D CHECK	(uses: PCB-31444-002)
MFG CHECK	SIZE
Edi Led Bu: aroemer	C DRAWING No. SCH-31442-002
Level Ed1: May 27, 2010, 10:07:26 am	REV 1 SHEET 18 OF 19

CAMERA

Camera

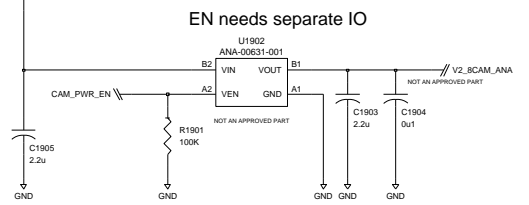
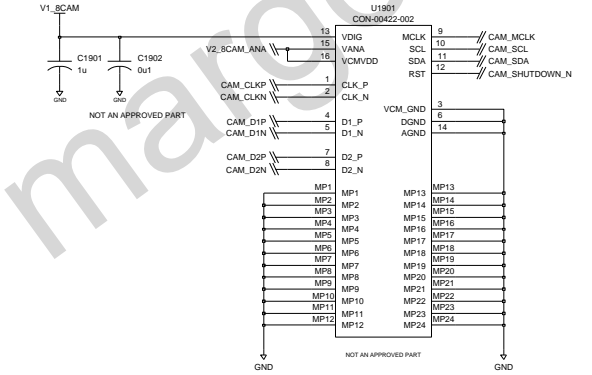

CAMERA ISP

U1903  
DIG-00388-002

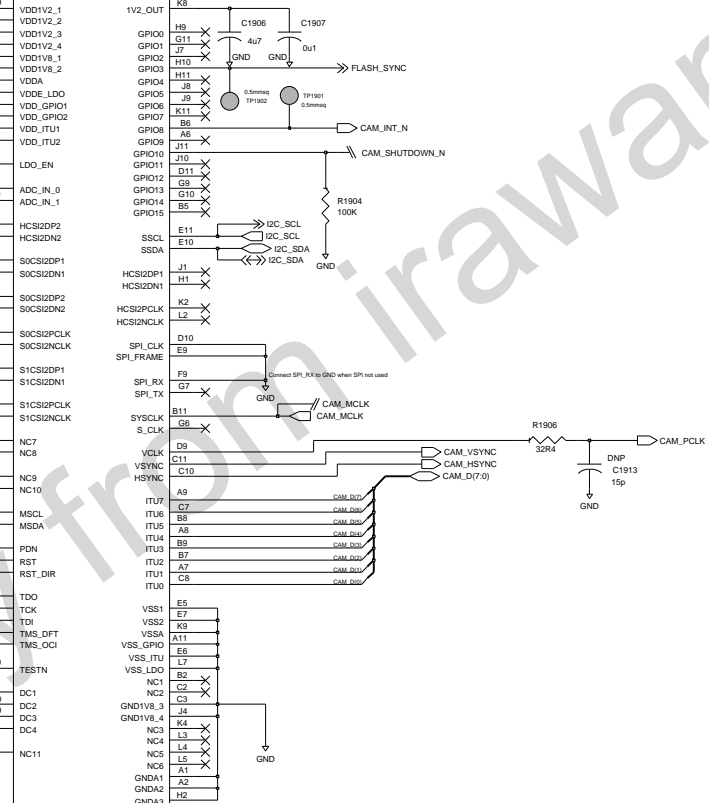

4

3

2

1

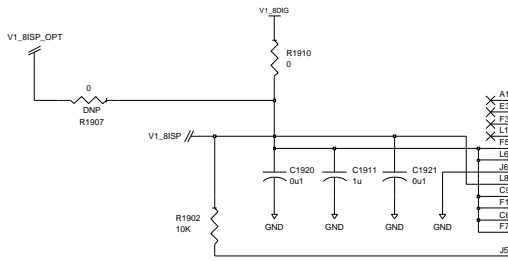
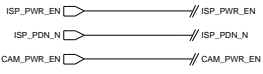
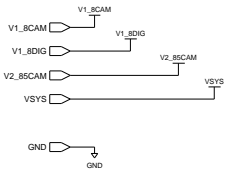

D

C

B

A

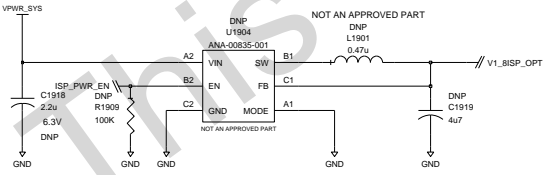

RESEARCH IN MOTION CONFIDENTIAL

HIERARCHICAL BLOCK JOINTERFACE3	COPYRIGHT 2010, RESEARCH IN MOTION LIMITED 295 PHILLIP ST. WATERLOO, ONTARIO, CANADA PHONE: (519) 888-7465, FAX (519) 888-6306
DRAWN BY: A. Roemer	TITLE R020 (Band I, II, V, VI)
R&D CHECK	(uses: PCB-31441-002)
DFG CHECK	SIZE DRAWING No. SCH-31442-002
Edi Led Bu: arnoemer	C REV 1 SHEET 19 OF 19
Label Ed1: Apr 30, 2010, 11:42:44 am	

4

3

2

1