

RESEARCH IN MOTION CONFIDENTIAL

HIERARCHICAL BLOCK		COPYRIGHT 2010, RESEARCH IN MOTION LIMITED	
MAIN		295 PHILLIP ST.	
DRAWN BY: RIM_OTTAWA		WATERLOO, ONTARIO, CANADA	
R&D CHECK		PHONE: (519) 888-7465, FAX (519) 888-6306	
IFG CHECK		TITLE	
Edi Led Bu: jmas		ESSEX	
Lobl Ed1: Jan 14, 2010, 4:53:19 pm		(Uses: PCB-24295-004)	
SIZE		DRAWING No. SCH-27613-004	
C		REV 1A SHEET 1 OF 16	

A B C D

A B C D

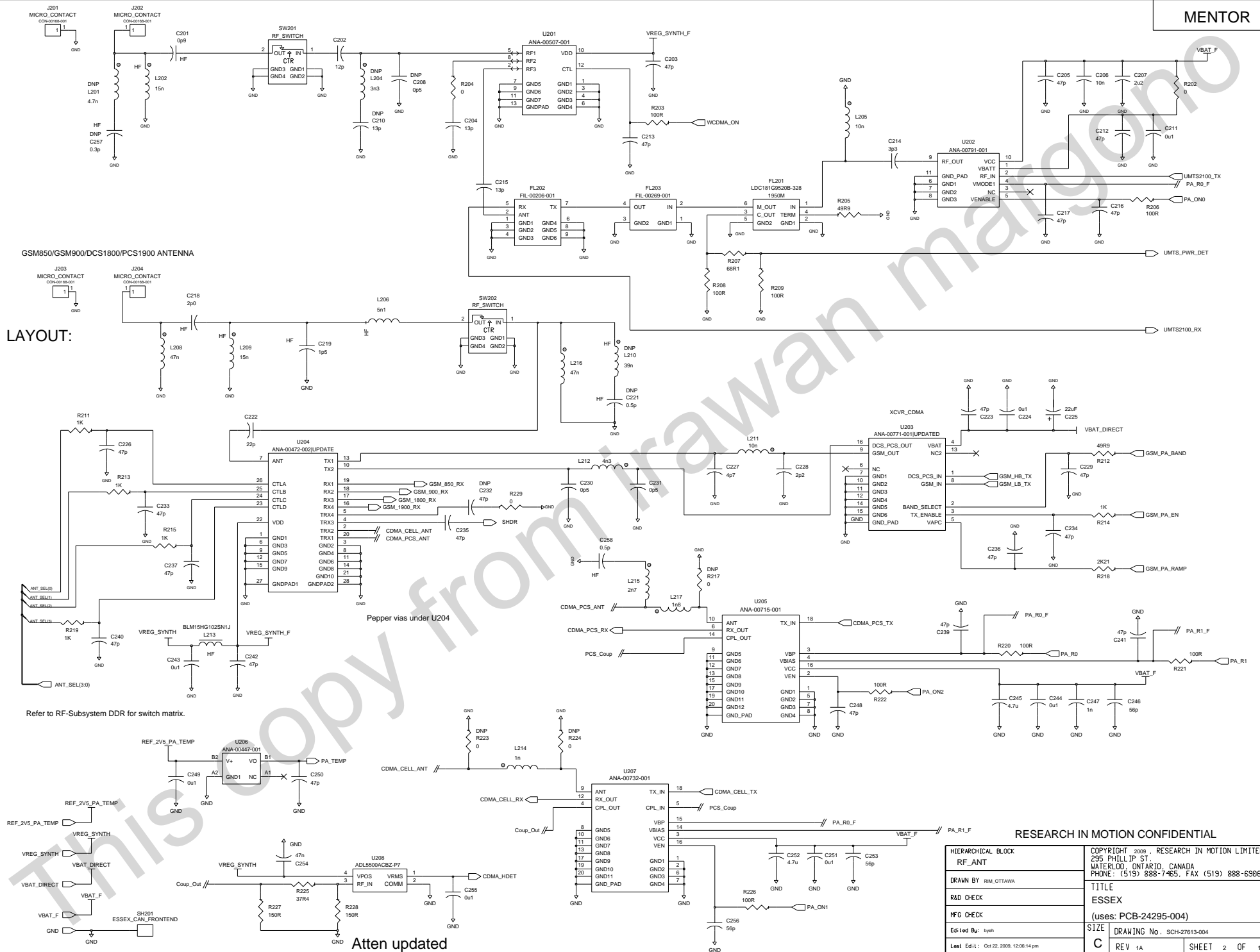

LAYOUT:

Pepper vias under U204

Refer to RF-Subsystem DDR for switch matrix.

Atten updated

RESEARCH IN MOTION CONFIDENTIAL

HIERARCHICAL BLOCK RF_ANT		COPYRIGHT 2009, RESEARCH IN MOTION LIMITED 295 PHILLIP ST. WATERLOO, ONTARIO, CANADA PHONE: (519) 888-7465, FAX (519) 888-6306	
DRAWN BY RIM.OTTAWA		TITLE ESSEX	
R&D CHECK		(uses: PCB-24295-004)	
MFG CHECK		SIZE DRAWING No. SCH-27613-004	
Edi Led Bu: bysh		C	
Level Ed1: Oct 22, 2009, 12:06:14 pm		REV 1A SHEET 2 OF 16	

D

D

C

C

B

B

A

A

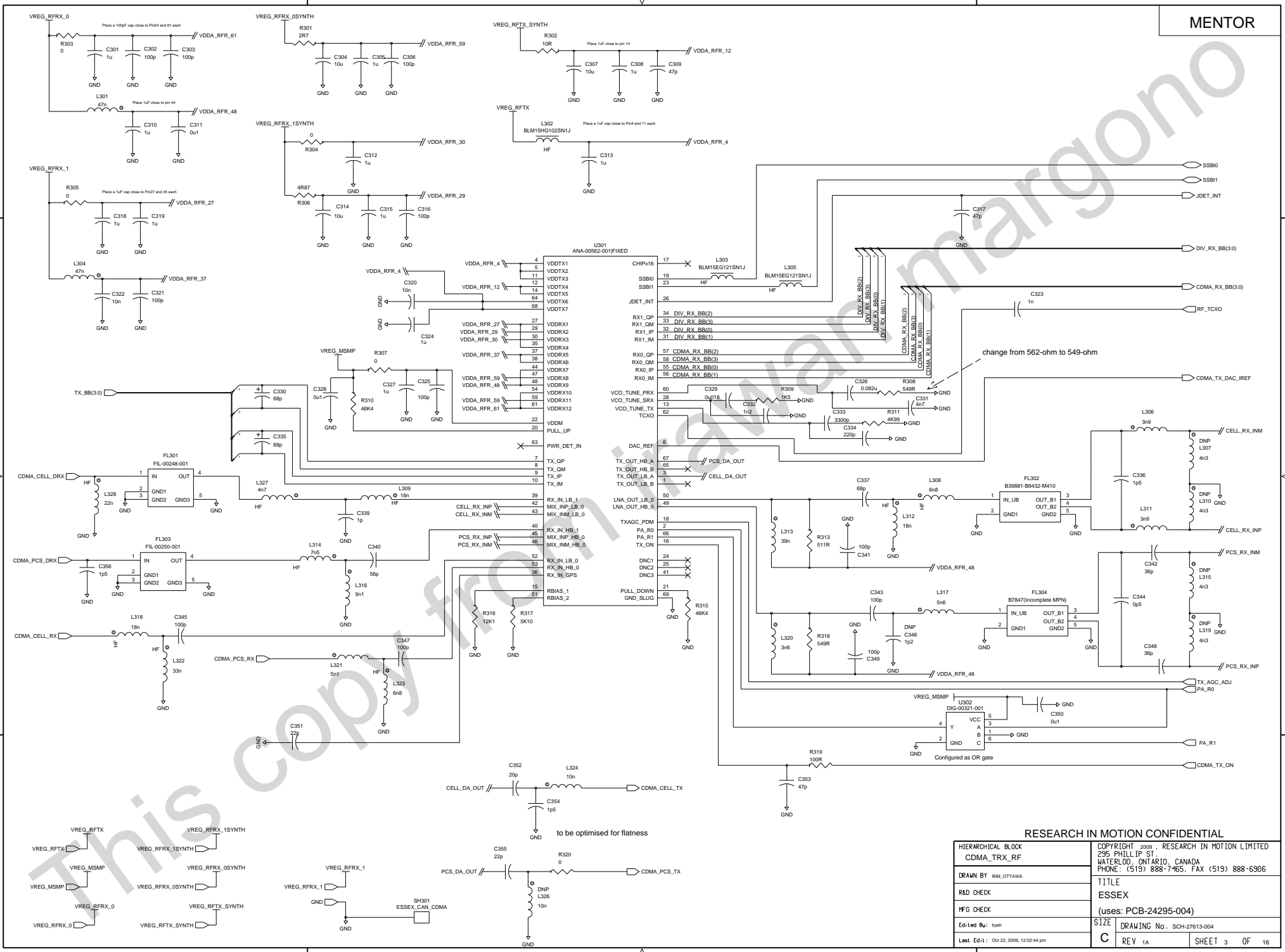

RESEARCH IN MOTION CONFIDENTIAL	
HIERARCHICAL BLOCK CDMA_TRX_RF	COPYRIGHT 2009, RESEARCH IN MOTION LIMITED 295 PHILLIP ST. WATERLOO, ONTARIO, CANADA PHONE: (519) 888-7465, FAX (519) 888-6306
DRAWN BY RIM.OTTAWA	TITLE ESSEX
R&D CHECK	(uses: PCB-24295-004)
IFG CHECK	SIZE DRAWING No. SCH-27613-004
Edi Led Bu: bysh	C REV 1A SHEET 3 OF 16
Level: Ed1:1 Oct 22, 2009, 12:02:44 pm	

D

D

C

C

B

B

A

A

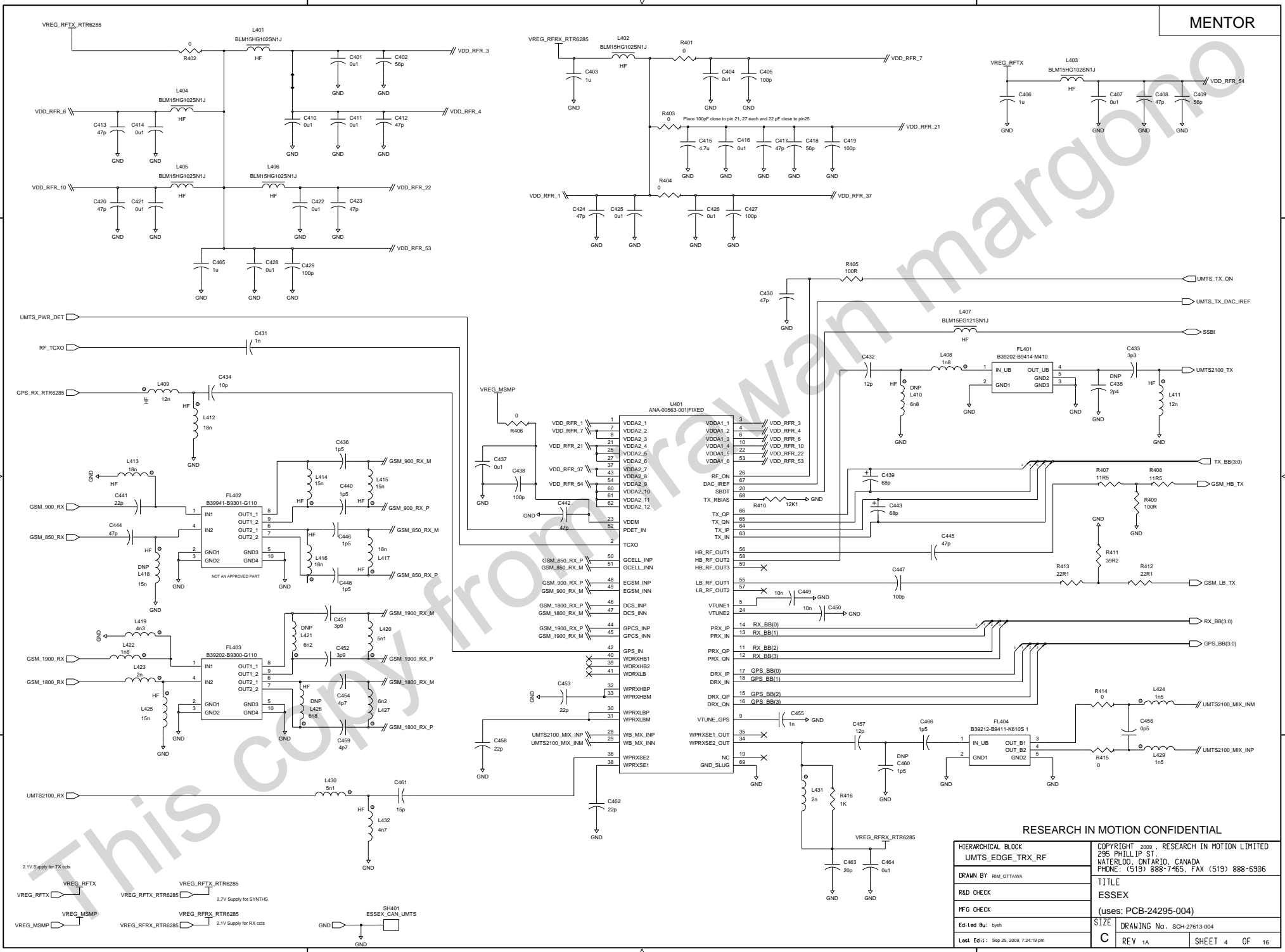

RESEARCH IN MOTION CONFIDENTIAL

HIERARCHICAL BLOCK UMTS_EDGE_TRX_RF		COPYRIGHT 2009, RESEARCH IN MOTION LIMITED 295 PHILLIP ST. WATERLOO, ONTARIO, CANADA PHONE: (519) 888-7465, FAX (519) 888-6306	
DRAWN BY RIM_OTTAWA		TITLE ESSEX	
R&D CHECK		IFG CHECK	
Ed: Led Bu: bysh		SIZE DRAWING No. SCH-27613-004	
Last Ed: 1: Sep 25, 2009, 7:24:19 pm		C REV 1A SHEET 4 OF 16	

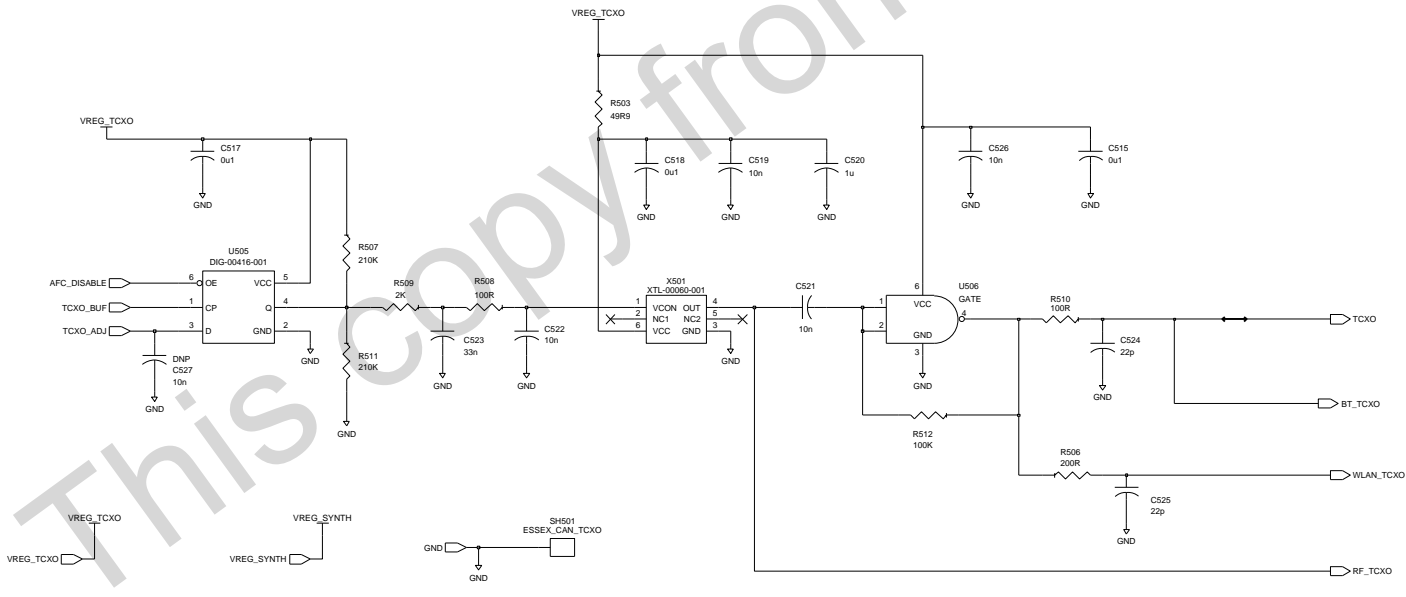
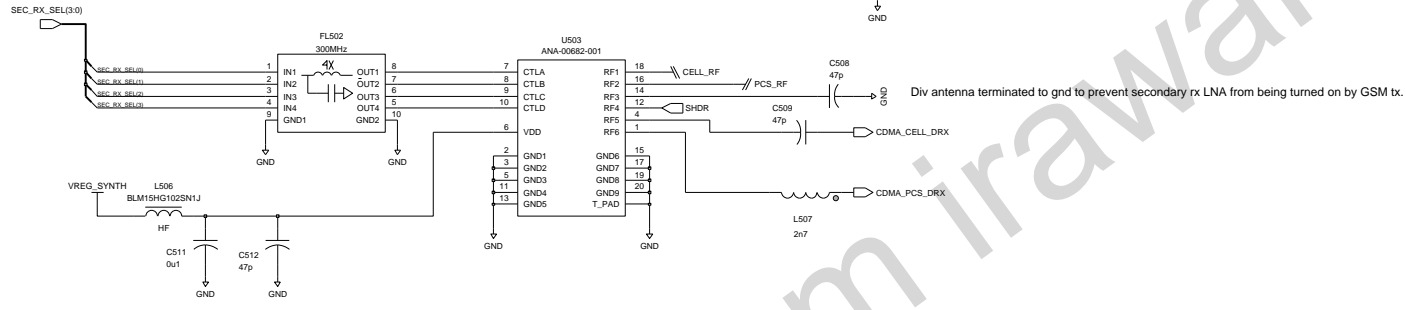
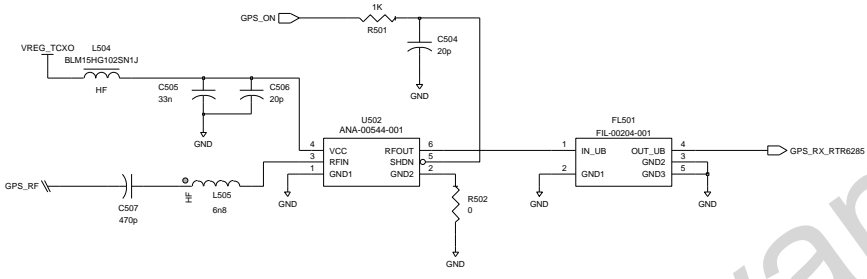
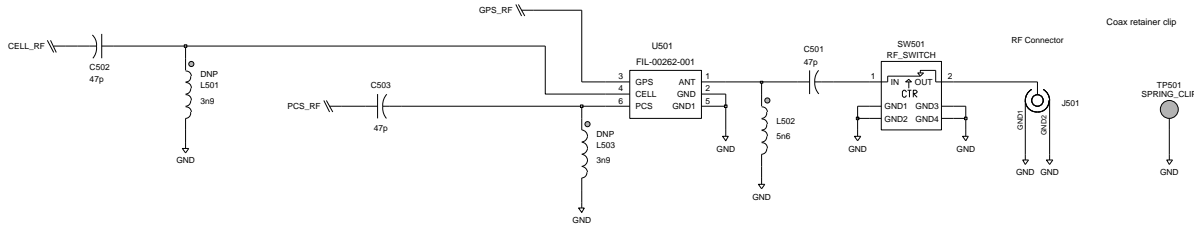

RESEARCH IN MOTION CONFIDENTIAL

HIERARCHICAL BLOCK GPS_SYNTH		COPYRIGHT 2009, RESEARCH IN MOTION LIMITED 295 PHILLIP ST. WATERLOO, ONTARIO, CANADA PHONE: (519) 888-7465, FAX (519) 888-6306	
DRAWN BY: RIM_OTTAWA		TITLE ESSEX	
R&D CHECK		(uses: PCB-24295-004)	
MFG CHECK		SIZE DRAWING No. SCH-27813-004	
Edi Led Bu: bysh		C	
Last Ed: Oct 22, 2009, 12:14:41 pm		REV 1A SHEET 5 OF 16	

MSM7600 32MB TURBO

U601
DG-00381-001

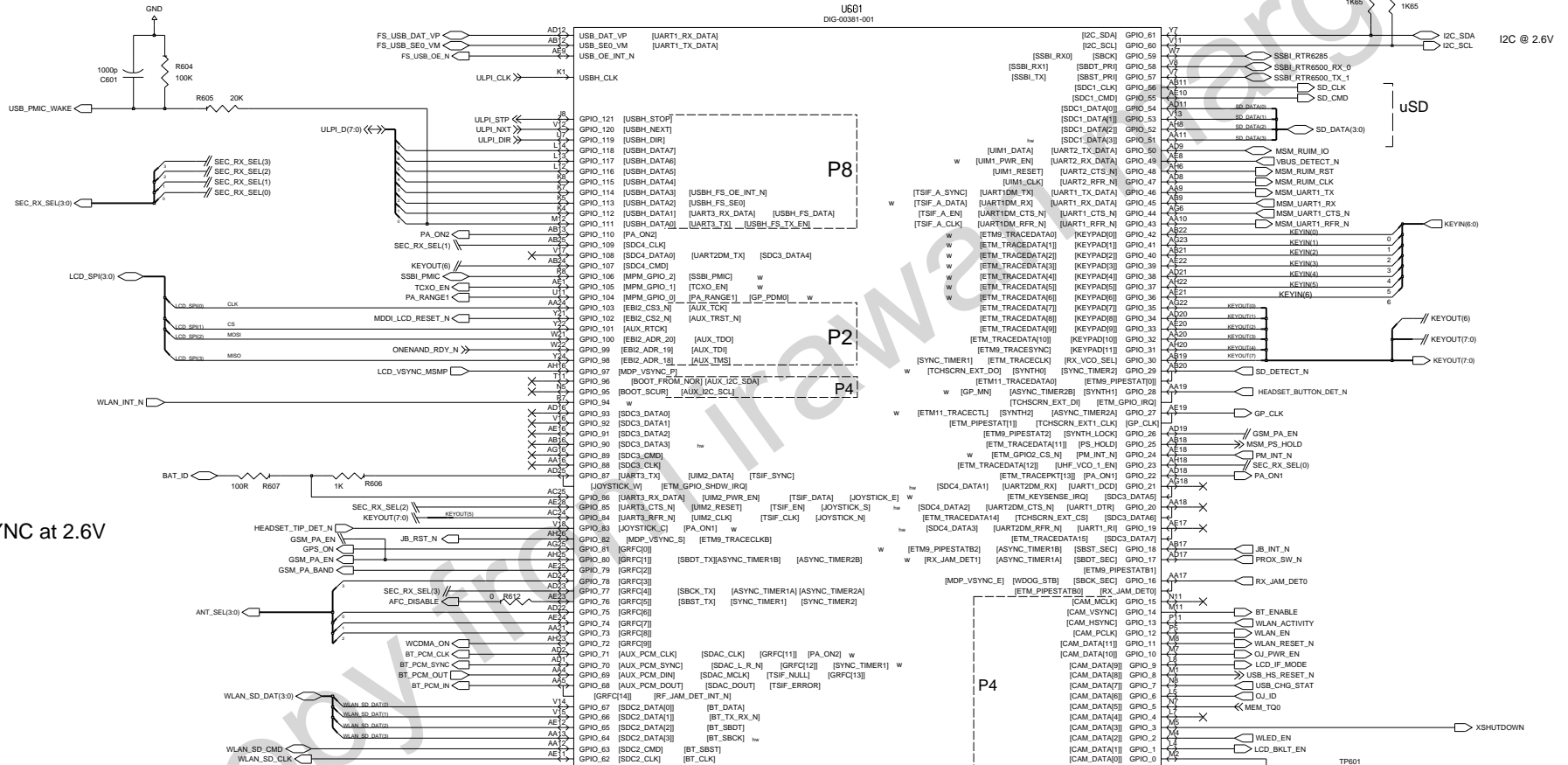

Note: VSYNC at 2.6V

RESEARCH IN MOTION CONFIDENTIAL

HIERARCHICAL BLOCK PROCESSOR		COPYRIGHT 2010, RESEARCH IN MOTION LIMITED 295 PHILLIP ST. WATERLOO, ONTARIO, CANADA PHONE: (519) 888-7465, FAX (519) 888-6306	
DRAWN BY RIM_OTTAWA		TITLE ESSEX	
R&D CHECK		MFG CHECK	
Edi Led Bu: jhalse		SIZE DRAWING No.: SCH-27613-004	
Last Ed1: Feb 10, 2010, 9:42:24 am		C REV 1A SHEET 6 OF 16	

MSM7600 32MB TURBO

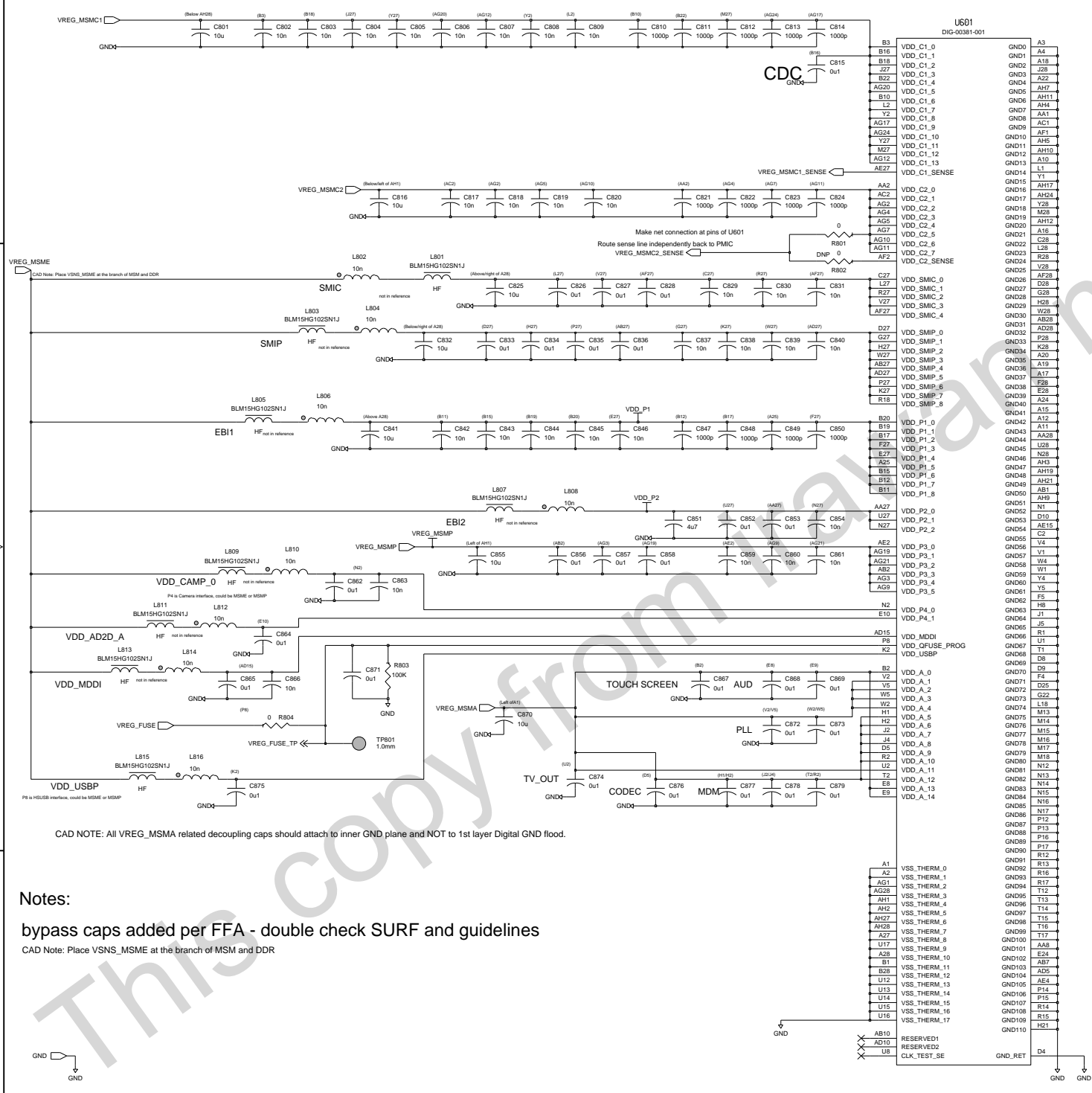

- A1 VSS_THERM_0
- A2 VSS_THERM_1
- AG1 VSS_THERM_2
- AG28 VSS_THERM_3
- AH1 VSS_THERM_4
- AH2 VSS_THERM_5
- AH27 VSS_THERM_6
- AK28 VSS_THERM_7
- A27 VSS_THERM_8
- U17 VSS_THERM_9
- U18 VSS_THERM_10
- B1 VSS_THERM_11
- B28 VSS_THERM_12
- U12 VSS_THERM_13
- U13 VSS_THERM_14
- U14 VSS_THERM_15
- U15 VSS_THERM_16
- U16 VSS_THERM_17

CAD NOTE: All VREG_MSMA related decoupling caps should attach to inner GND plane and NOT to 1st layer Digital GND flood.

Notes:
 bypass caps added per FFA - double check SURF and guidelines
 CAD Note: Place VSNS_MSME at the branch of MSM and DDR

RESEARCH IN MOTION CONFIDENTIAL	
HIERARCHICAL BLOCK PROCESSOR3	COPYRIGHT 2009, RESEARCH IN MOTION LIMITED 295 PHILLIP ST. WATERLOO, ONTARIO, CANADA PHONE: (519) 888-7465, FAX (519) 888-6306
DRAWN BY RIM_OTTAWA	TITLE ESSEX
R&D CHECK	(uses: PCB-24295-004)
IFG CHECK	SIZE DRAWING No. SCH-27613-004
Edi Led Bu: byeh	REV 1A
Last Edt: Aug 27, 2009, 9:31:34 am	SHEET 8 OF 16

MSM7600 32MB TURBO

U601
DIG-00381-001

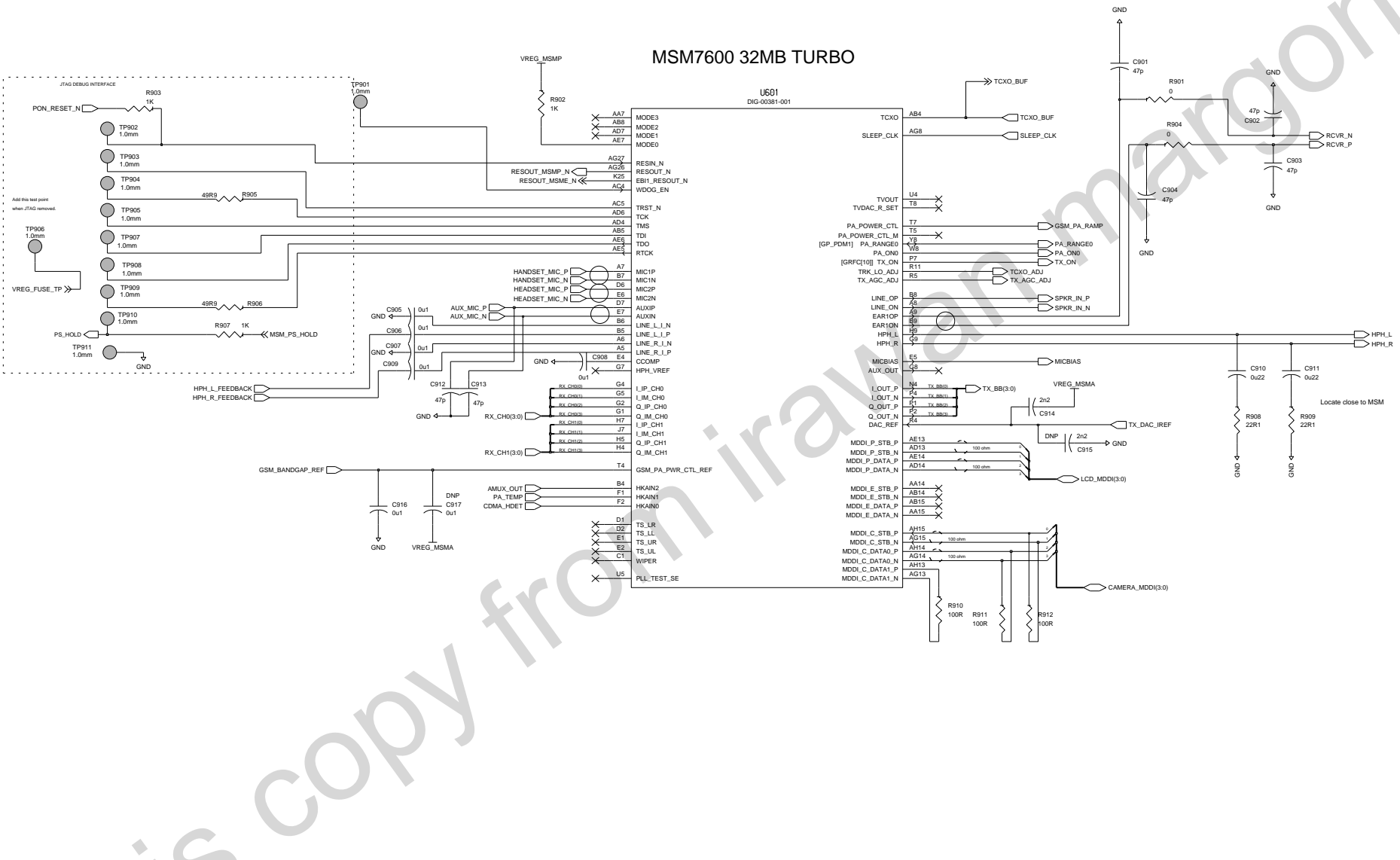

RESEARCH IN MOTION CONFIDENTIAL

HIERARCHICAL BLOCK PROCESSOR4		COPYRIGHT 2009, RESEARCH IN MOTION LIMITED 295 PHILLIP ST. WATERLOO, ONTARIO, CANADA PHONE: (519) 888-7465, FAX (519) 888-6306	
DRAWN BY RIM_OTTAWA		TITLE ESSEX	
R&D CHECK		(uses: PCB-24295-004)	
NFG CHECK		SIZE DRAWING No. SCH-27813-004	
Edi Led Bu: bysh		C	
Level Ed1: May 8, 2009, 7:29:50 pm		REV 1A	SHEET 9 OF 16

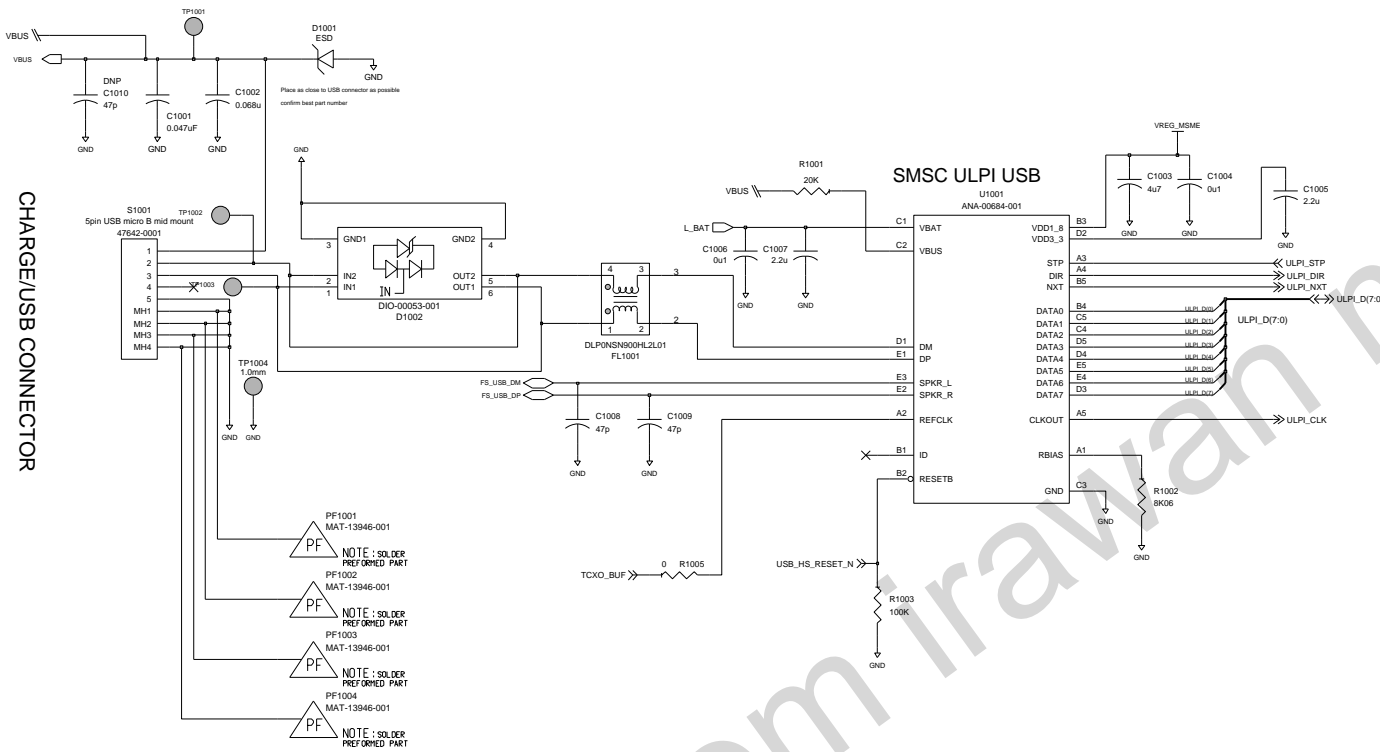

RESEARCH IN MOTION CONFIDENTIAL

HIERARCHICAL BLOCK PROCESSORS		COPYRIGHT 2009, RESEARCH IN MOTION LIMITED 295 PHILLIP ST. WATERLOO, ONTARIO, CANADA PHONE: (519) 888-7465, FAX (519) 888-6306	
DRAWN BY: RIM_OTTAWA		TITLE ESSEX	
R&D CHECK		(uses: PCB-24295-004)	
MFG CHECK		SIZE DRAWING No. SCH-27613-004	
Edi Led Bu: bysh		C	
Last Ed: Oct 22, 2009, 2:46:04 pm		REV 1A	SHEET 10 OF 16

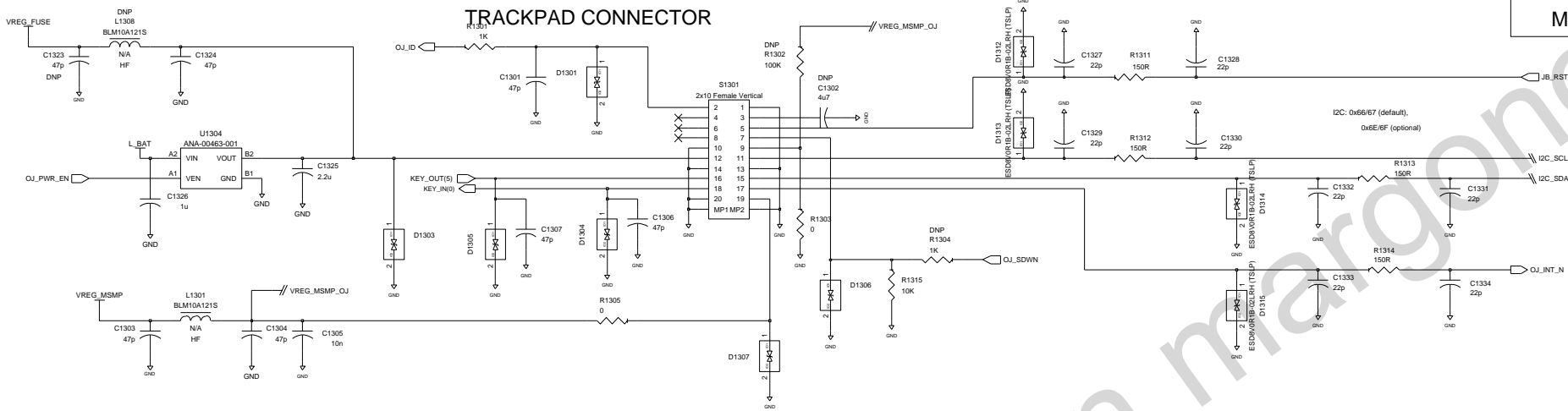

LCD CONNECTOR

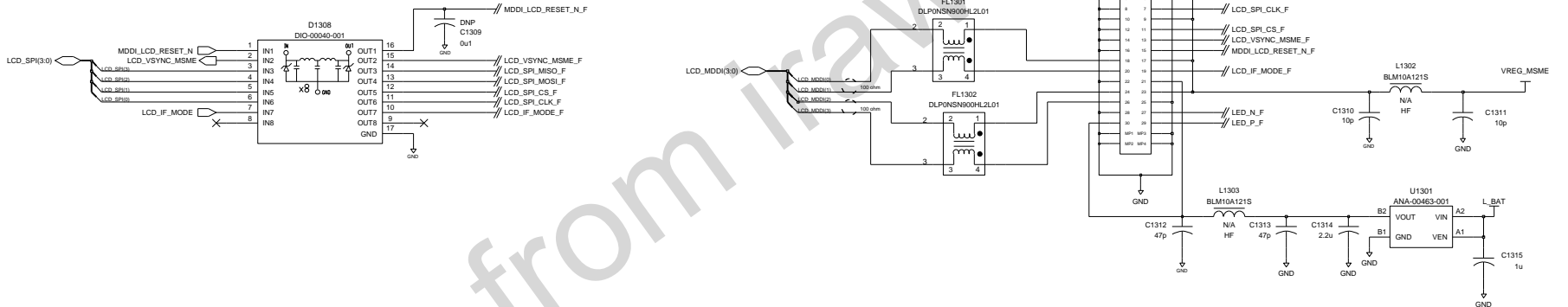

BACK-LIGHT/TRI-COLOR LED

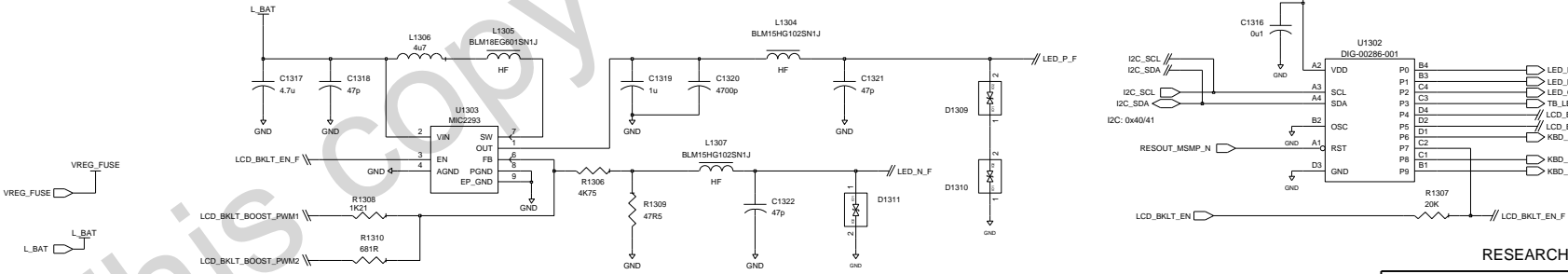

RESEARCH IN MOTION CONFIDENTIAL

HIERARCHICAL BLOCK JOINTERFACE		COPYRIGHT 2010, RESEARCH IN MOTION LIMITED 295 PHILLIP ST. WATERLOO, ONTARIO, CANADA PHONE: (519) 888-7465, FAX (519) 888-6306	
DRAWN BY: RIM_GTTAWA		TITLE ESSEX	
R&D CHECK		(uses: PCB-24295-004)	
MFG CHECK		SIZE DRAWING No. BCH-27613-004	
Edi Led Bu: jmlie		C	
Level: Ed1:1 Jan 28, 2010, 1:19:52 pm		REV 1A SHEET 13 OF 16	

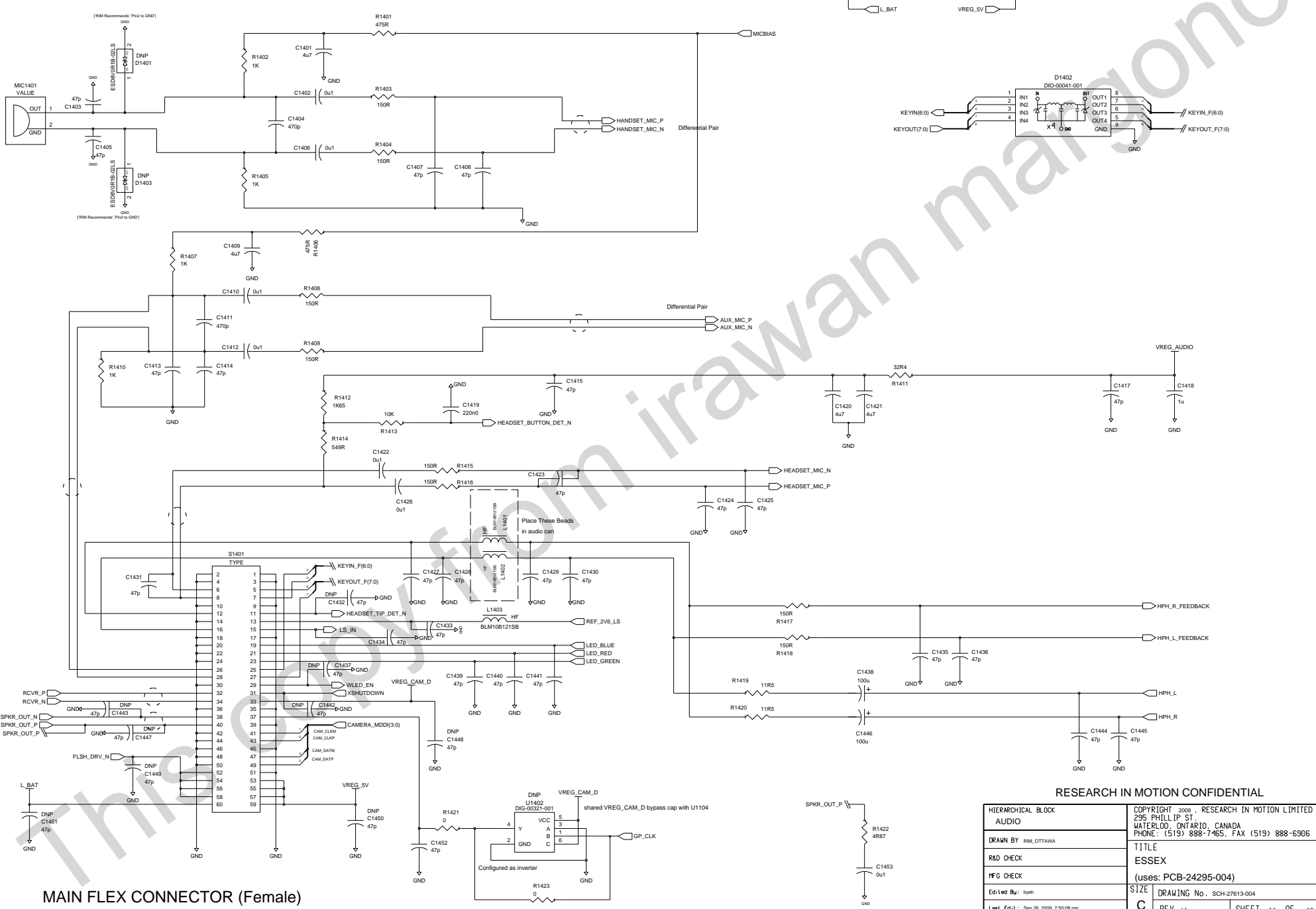

MAIN FLEX CONNECTOR (Female)

RESEARCH IN MOTION CONFIDENTIAL

HIERARCHICAL BLOCK AUDIO		COPYRIGHT 2009, RESEARCH IN MOTION LIMITED 295 PHILLIP ST. WATERLOO, ONTARIO, CANADA PHONE: (519) 888-7465, FAX (519) 888-6306	
DRAWN BY RIM.OTTAWA		TITLE ESSEX	
R&D CHECK		MFG CHECK	
Ed: Led Bu: bysh		SIZE DRAWING No. SCH-27613-004	
Last Ed: 1 Sep 26, 2009, 7:50:08 pm		C REV 1A SHEET 14 OF 16	

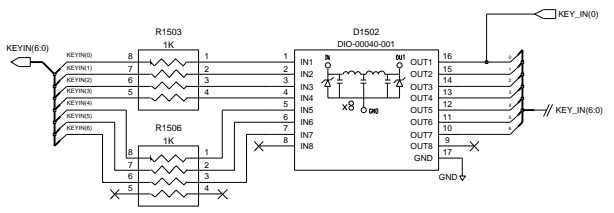
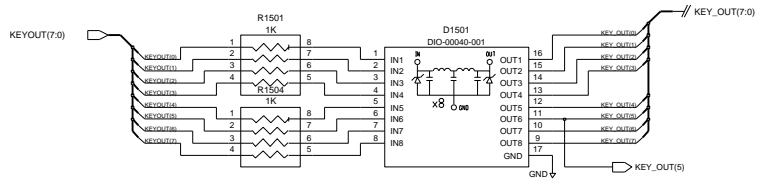

Keyboard Connector

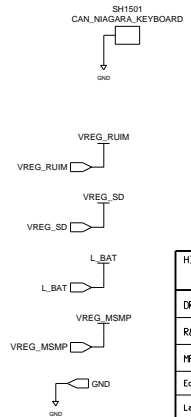
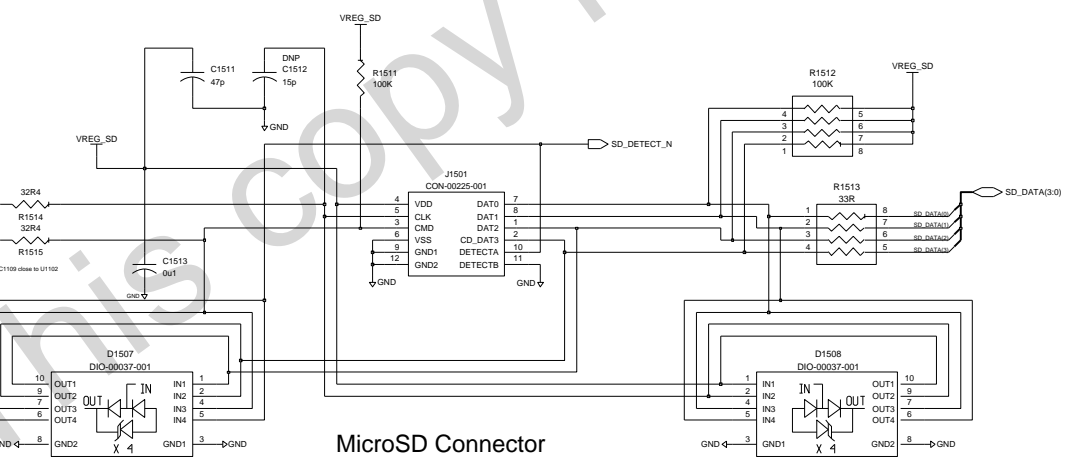
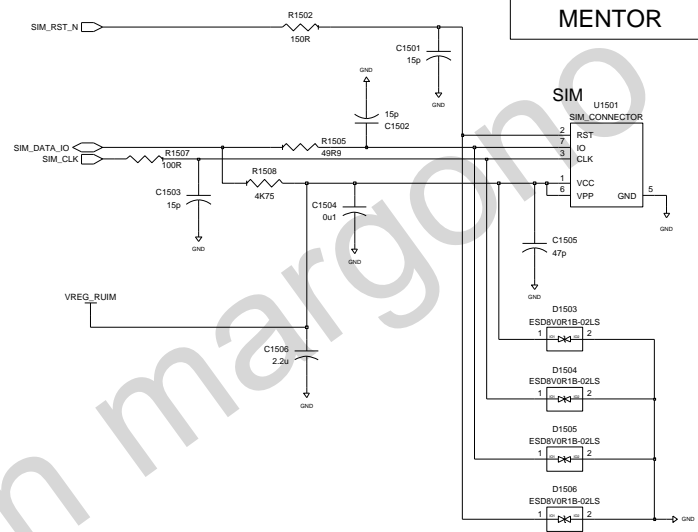
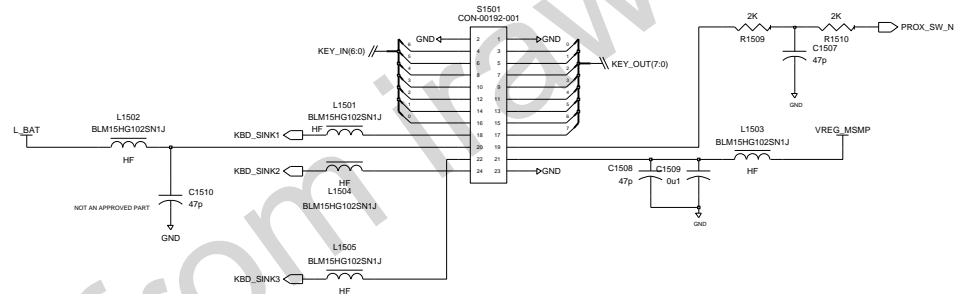

RESEARCH IN MOTION CONFIDENTIAL

HIERARCHICAL BLOCK KEYBRD		COPYRIGHT 2009, RESEARCH IN MOTION LIMITED 295 PHILLIP ST. WATERLOO, ONTARIO, CANADA PHONE: (519) 888-7465, FAX (519) 888-6306	
DRAWN BY: RIM_OTTAWA		TITLE ESSEX	
R&D CHECK		(uses: PCB-24295-004)	
MFG CHECK		SIZE DRAWING No. SCH-27613-004	
Edi Led Bu: bysh		C	
Last Ed: 1 Aug 27, 2009, 9:38:54 am		REV 1A	SHEET 15 OF 16

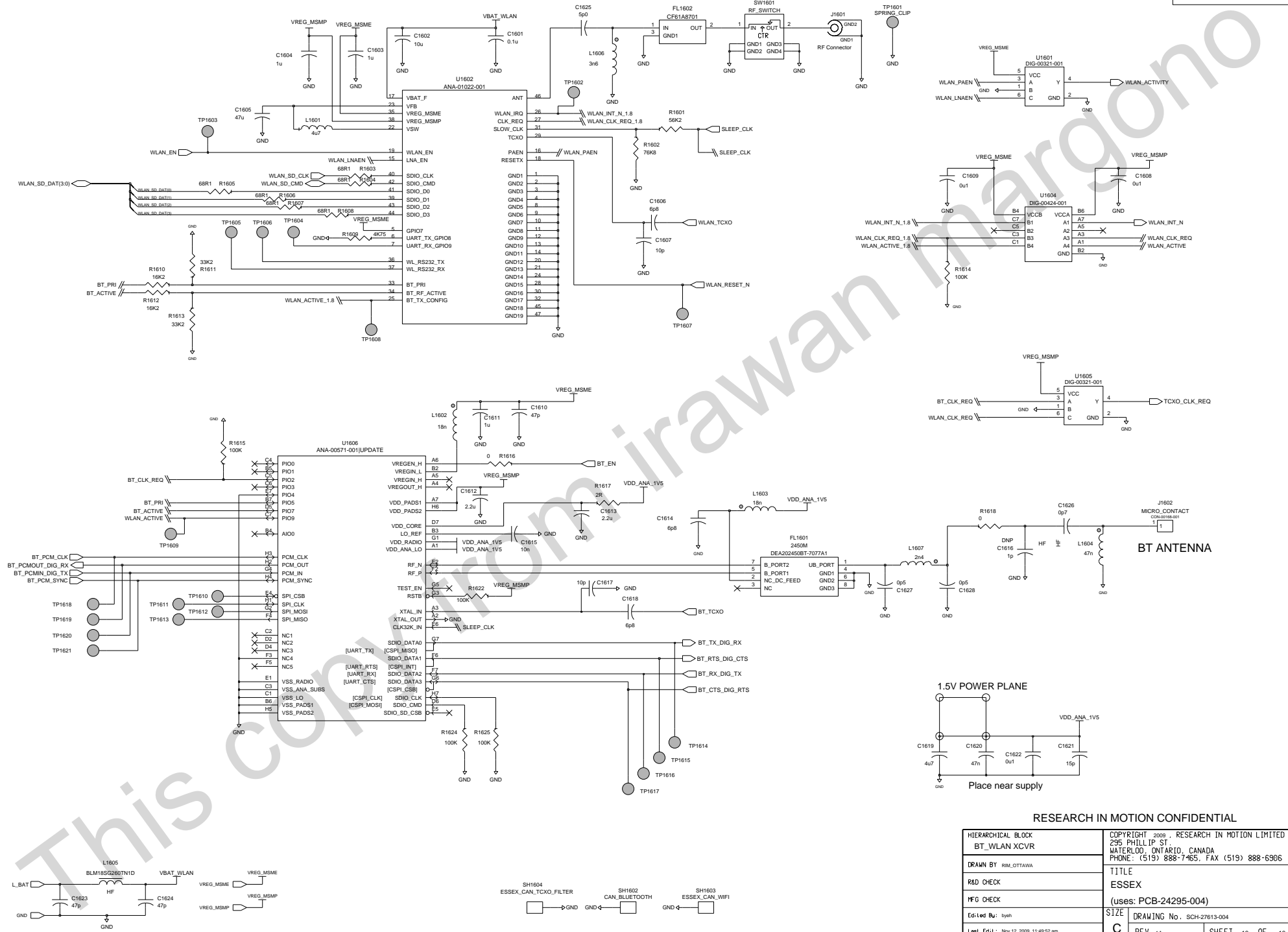

RESEARCH IN MOTION CONFIDENTIAL

HIERARCHICAL BLOCK BT_WLAN_XCVR		COPYRIGHT 2009, RESEARCH IN MOTION LIMITED 295 PHILLIP ST. WATERLOO, ONTARIO, CANADA PHONE: (519) 888-7465, FAX (519) 888-6306	
DRAWN BY RIM.OTTAWA		TITLE ESSEX	
R&D CHECK		MFG CHECK	
Edi Led Bu: bysh		SIZE DRAWING No. SCH-27613-004	
Last Ed:11 Nov 12, 2009, 11:49:52 am		REV 1A SHEET 16 OF 16	