

HIERARCHICAL BLOCK MAIN		COPYRIGHT 2010, RESEARCH IN MOTION LIMITED WATERLOO, ONTARIO, CANADA PHONE: (519) 888-7465, FAX (519) 888-6306
DRAWN BY Raman Sharma		
R&D CHECK (Uses: PCB-20335-005)		
IFG CHECK Ed: Led Bu: andrstrw		
TITLE Niagara - China Telecom		SIZE DRAWING No. SCH-31764-001
Model Ed1: May 11, 2010, 1:40:00 pm		
REV 1A		SHEET 1 OF 16

D

D

C

C

B

B

A

A

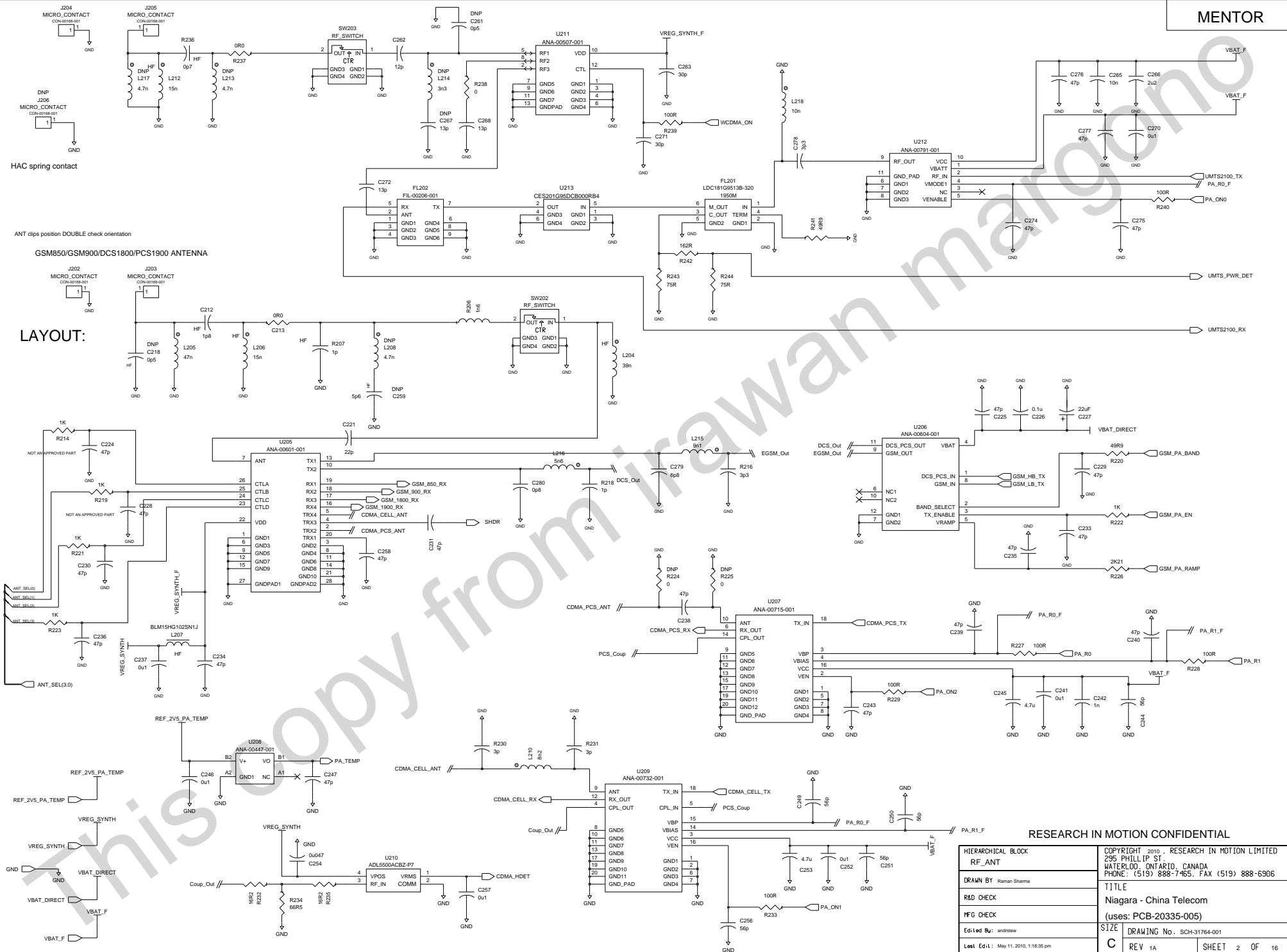

LAYOUT:

RESEARCH IN MOTION CONFIDENTIAL

HIERARCHICAL BLOCK	RF_ANT	COPYRIGHT 2010, RESEARCH IN MOTION LIMITED
DRAWN BY	Raman Sharma	295 PHILLIP ST.
R&D CHECK		WATERLOO, ONTARIO, CANADA
IFG CHECK		PHONE: (519) 888-7465, FAX (519) 888-6306
Edi Led By:	andrew	TITLE
Level Ed1:	May 11, 2010, 1:18:35 pm	Niagara - China Telecom
		(uses: PCB-20335-005)
		SIZE
		DRAWING No. SCH-31764-001
		REV 1A
		SHEET 2 OF 16

D

D

C

C

B

B

A

A

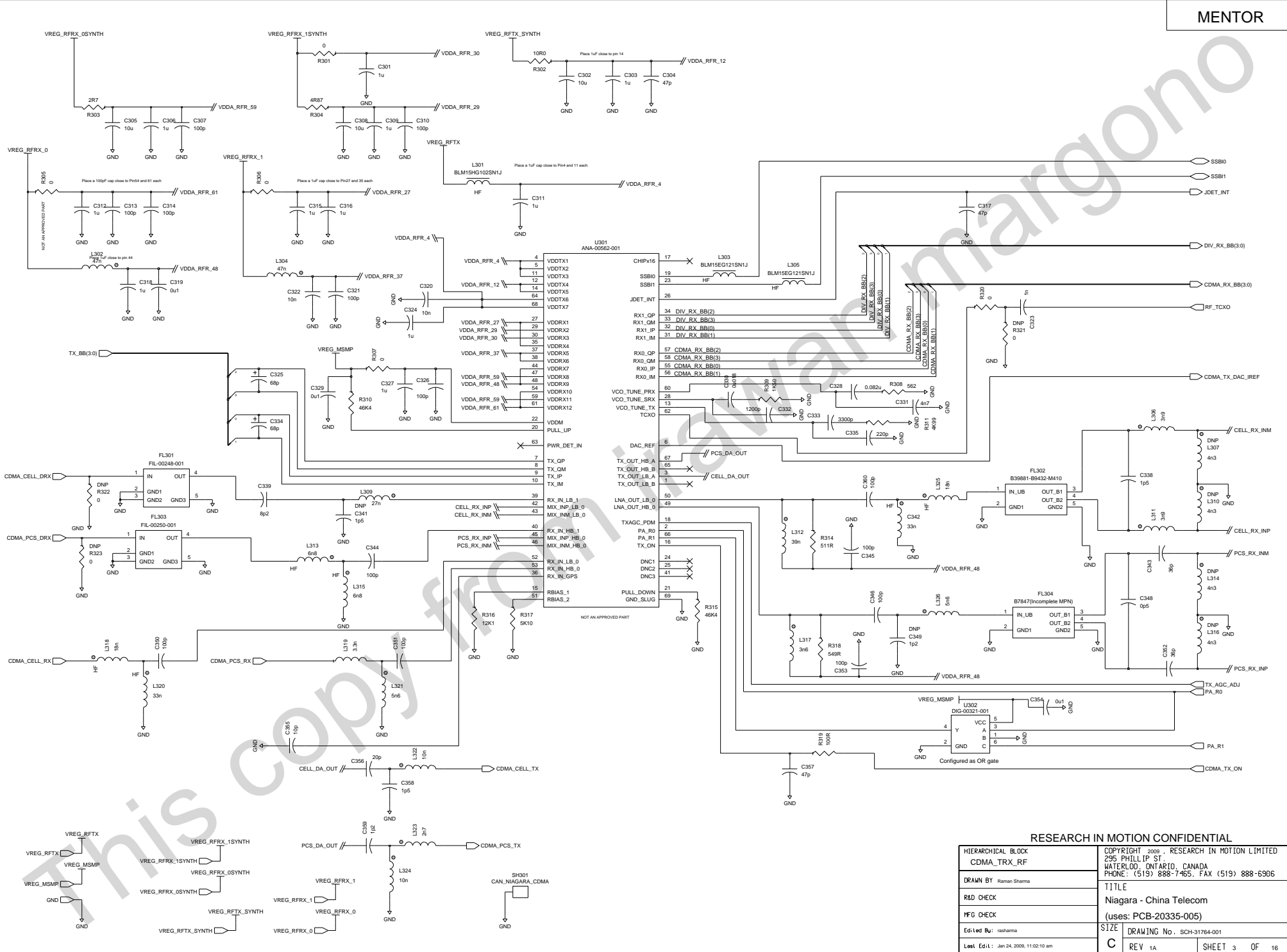

RESEARCH IN MOTION CONFIDENTIAL

HIERARCHICAL BLOCK CDMA_TRX_RF		COPYRIGHT 2009, RESEARCH IN MOTION LIMITED 295 PHILLIP ST. WATERLOO, ONTARIO, CANADA PHONE: (519) 888-7465, FAX (519) 888-6306	
DRAWN BY Raman Sharma		TITLE Niagara - China Telecom	
R&D CHECK		(uses: PCB-20335-005)	
MFG CHECK		SIZE DRAWING No. SCH-31764-001	
Edi Led By: rsharma		C	
Level: Ed1: Jan 24, 2009, 11:02:10 am		REV 1A	SHEET 3 OF 16

D

D

C

C

B

B

A

A

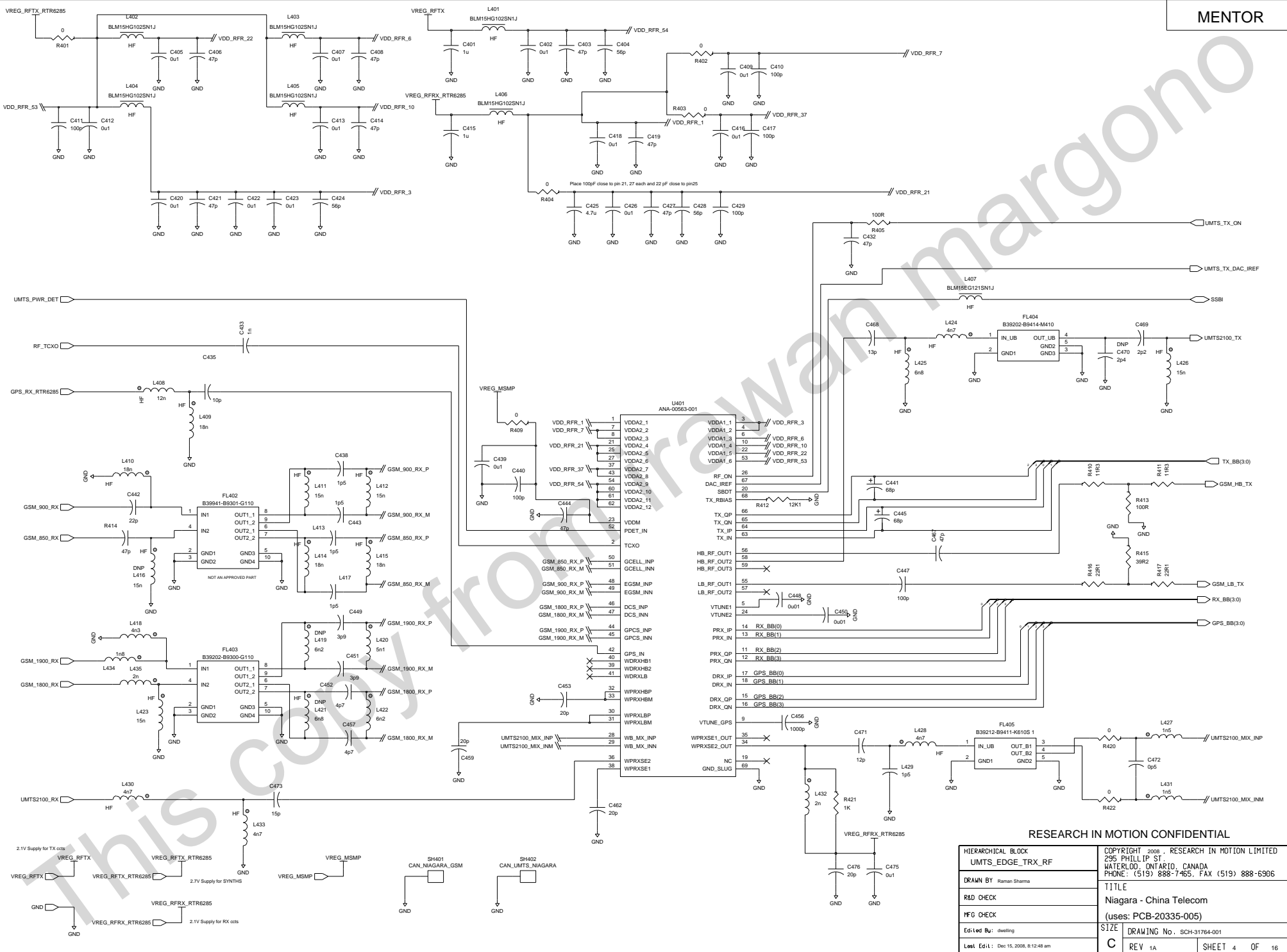

RESEARCH IN MOTION CONFIDENTIAL

HIERARCHICAL BLOCK UMTS_EDGE_TRX_RF		COPYRIGHT 2008, RESEARCH IN MOTION LIMITED 295 PHILLIP ST. WATERLOO, ONTARIO, CANADA PHONE: (519) 888-7465, FAX (519) 888-6306	
DRAWN BY Raman Sharma		TITLE Niagara - China Telecom (uses: PCB-20335-005)	
R&D CHECK		SIZE DRAWING No. SCH-31764-001	
HFQ CHECK		C REV 1A SHEET 4 OF 16	
Edi Led Bu: dwelling		Level: Ed1:1 Date: 15, 2008, 8:12:48 am	

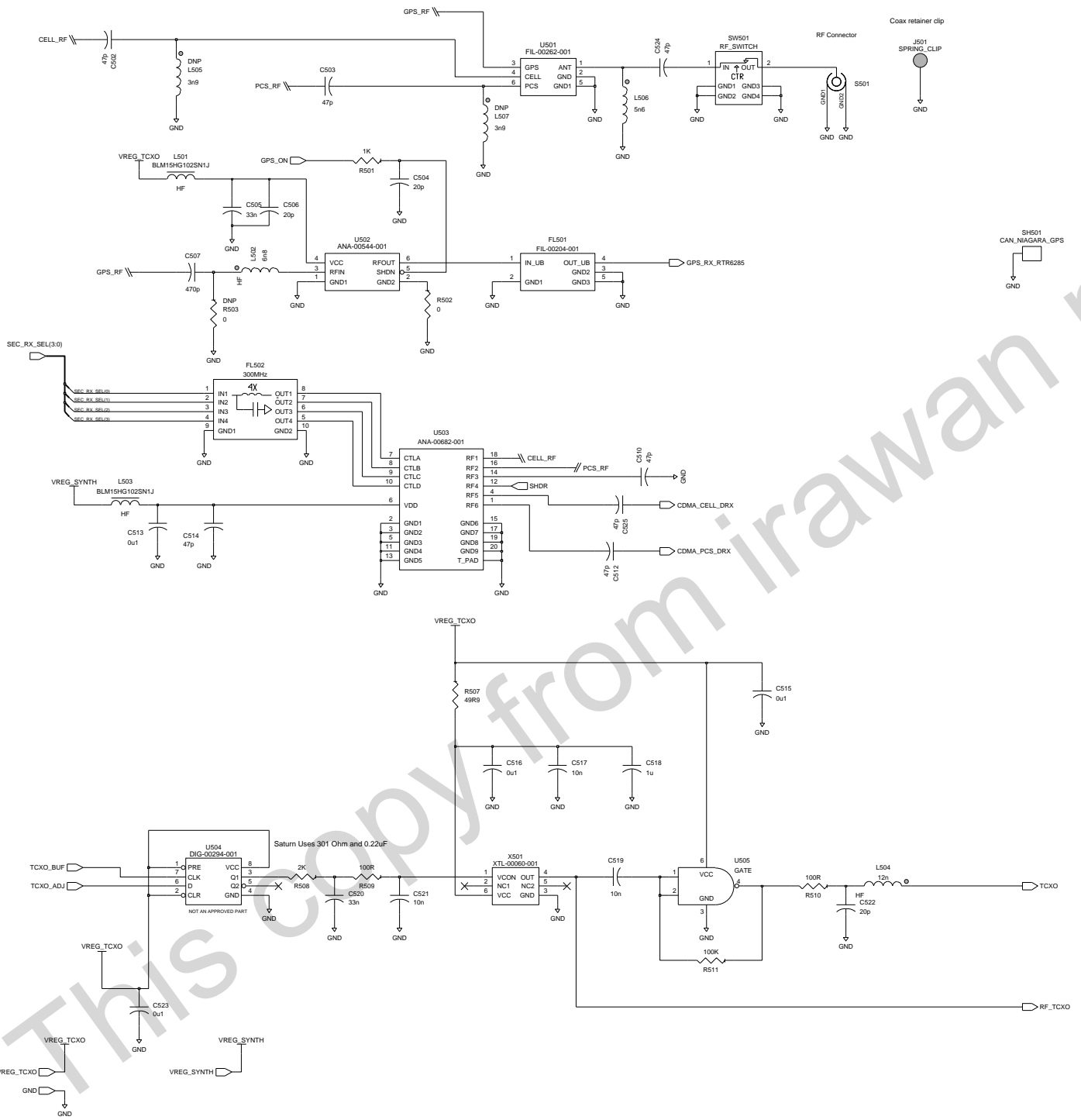

RESEARCH IN MOTION CONFIDENTIAL

HIERARCHICAL BLOCK GPS_SYNTH		COPYRIGHT 2009, RESEARCH IN MOTION LIMITED 295 PHILLIP ST. WATERLOO, ONTARIO, CANADA PHONE: (519) 888-7465, FAX (519) 888-6306	
DRAWN BY Raman Sharma		TITLE Niagara - China Telecom	
R&D CHECK		(uses: PCB-20335-005)	
MFG CHECK		SIZE DRAWING No. SCH-31764-001	
Edi Led By: dwelling		C REV 1A SHEET 5 OF 16	
Last Ed: Jan 30, 2009, 2:08:03 pm			

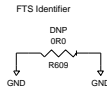

U601
DIG-00316-001

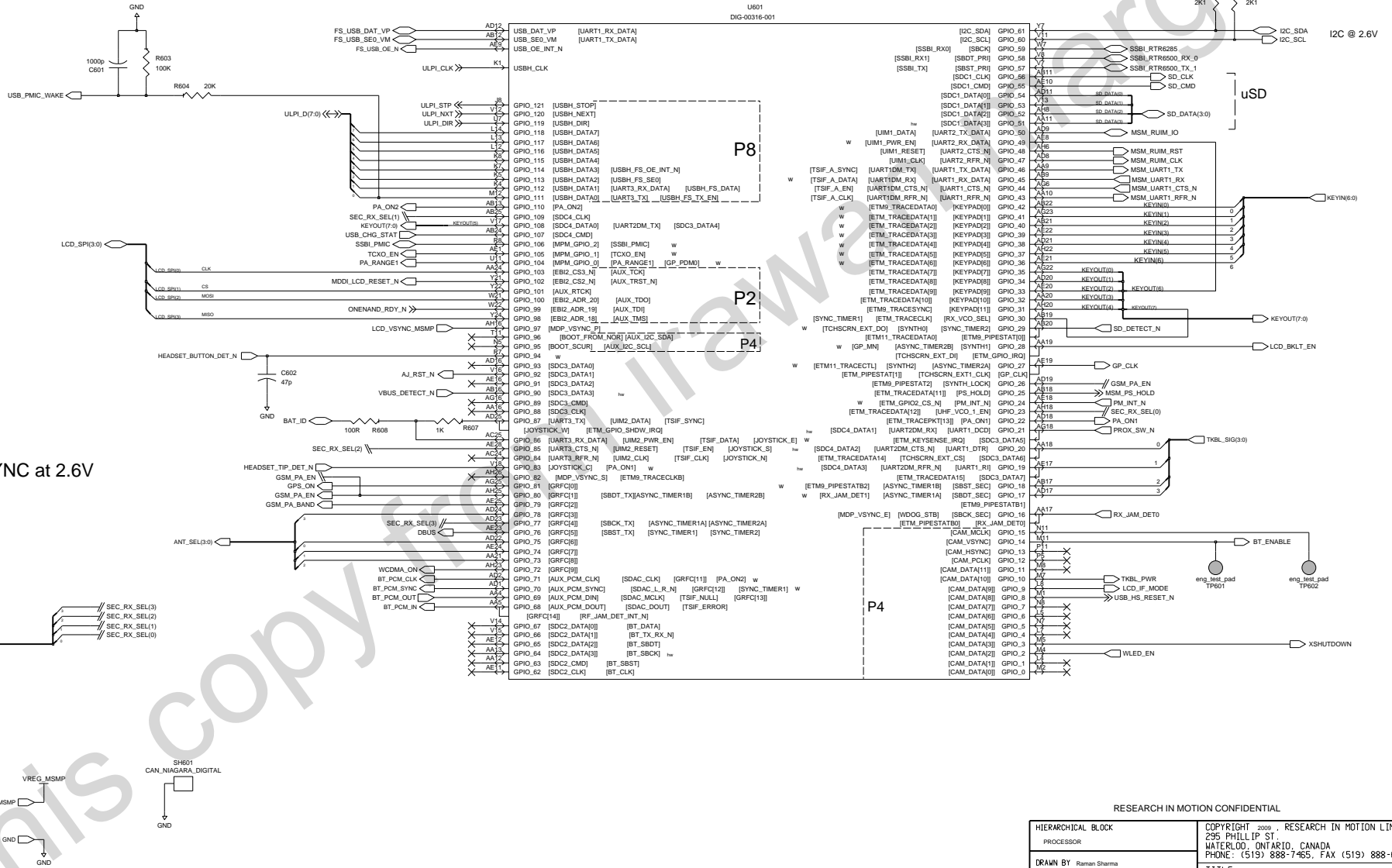

Note: VSYNC at 2.6V

RESEARCH IN MOTION CONFIDENTIAL

HIERARCHICAL BLOCK PROCESSOR	COPYRIGHT 2009, RESEARCH IN MOTION LIMITED 295 PHILLIP ST. WATERLOO, ONTARIO, CANADA PHONE: (519) 888-7465, FAX (519) 888-6306
DRAWN BY Raman Sharma	TITLE Niagara - China Telecom (uses: PCB-20335-005)
R&D CHECK	SIZE DRAWING No. SCH-31764-001
IFG CHECK	C REV 1A SHEET 6 OF 16
Edi Led Bu: dwelling	
Level Ed1: May 26, 2009, 11:12:27 am	

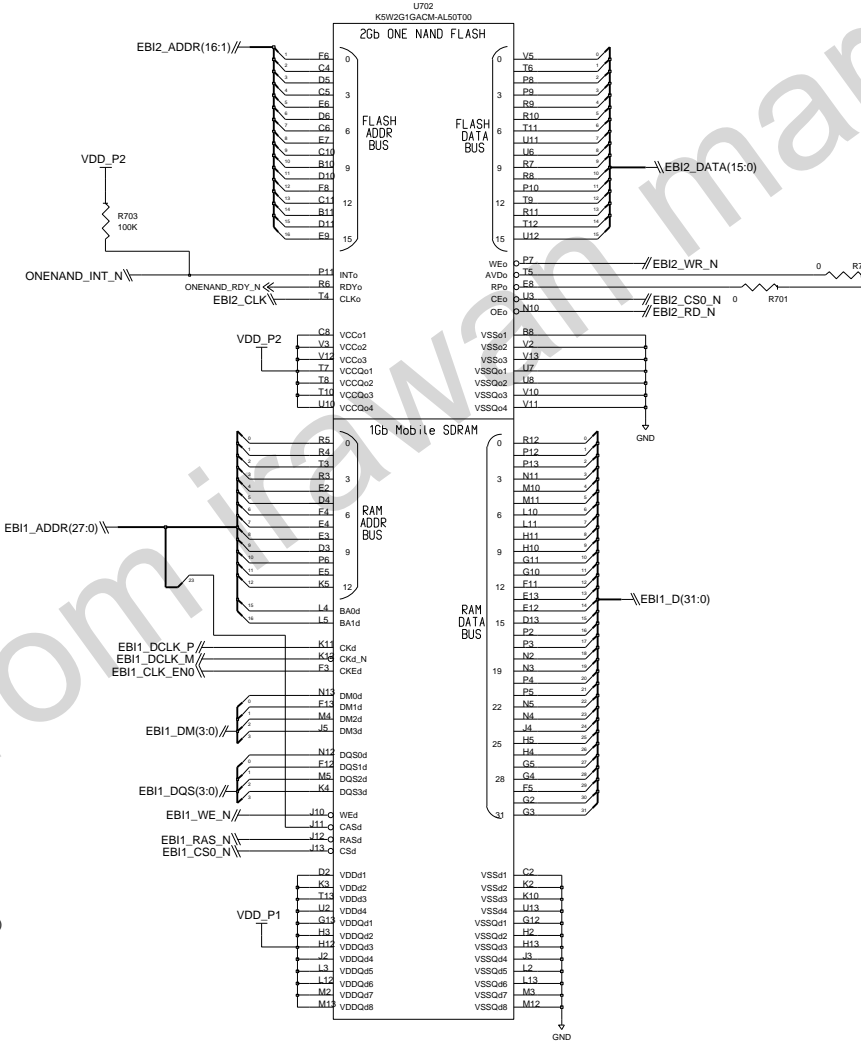
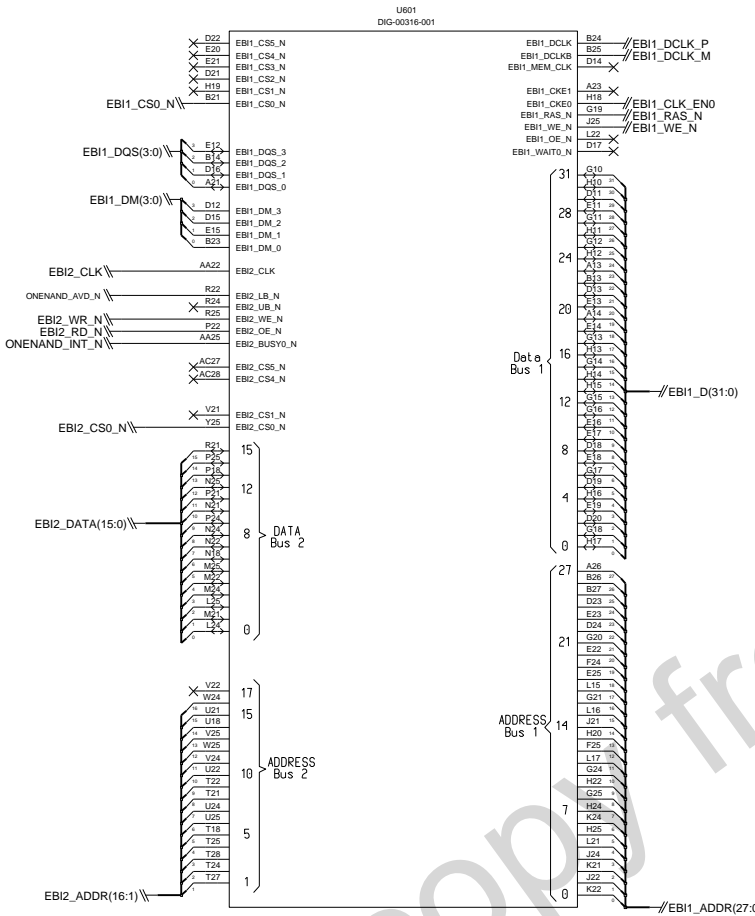
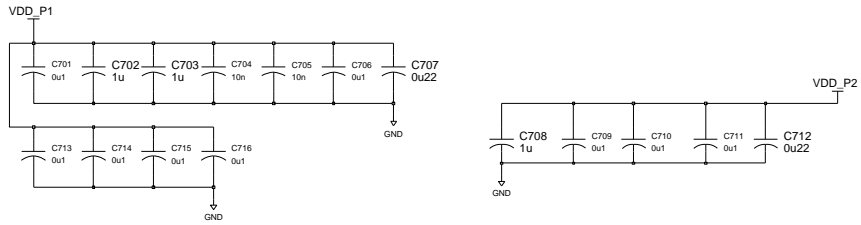

RESEARCH IN MOTION CONFIDENTIAL

HIERARCHICAL BLOCK PROCESSOR2	COPYRIGHT 2008 RESEARCH IN MOTION LIMITED 295 PHILLIP ST. WATERLOO, ONTARIO, CANADA PHONE: (519) 888-7465, FAX (519) 888-6306
DRAWN BY Raman Sharma	TITLE Niagara - China Telecom
R&D CHECK	(uses: PCB-20335-005)
IFG CHECK	SIZE DRAWING No. SCH-31764-001
Ed: Led Bu: dwelling	C REV 1A SHEET 7 OF 16
Last Ed: Jun 27, 2008, 2:14:17 pm	

This copy from m... margono

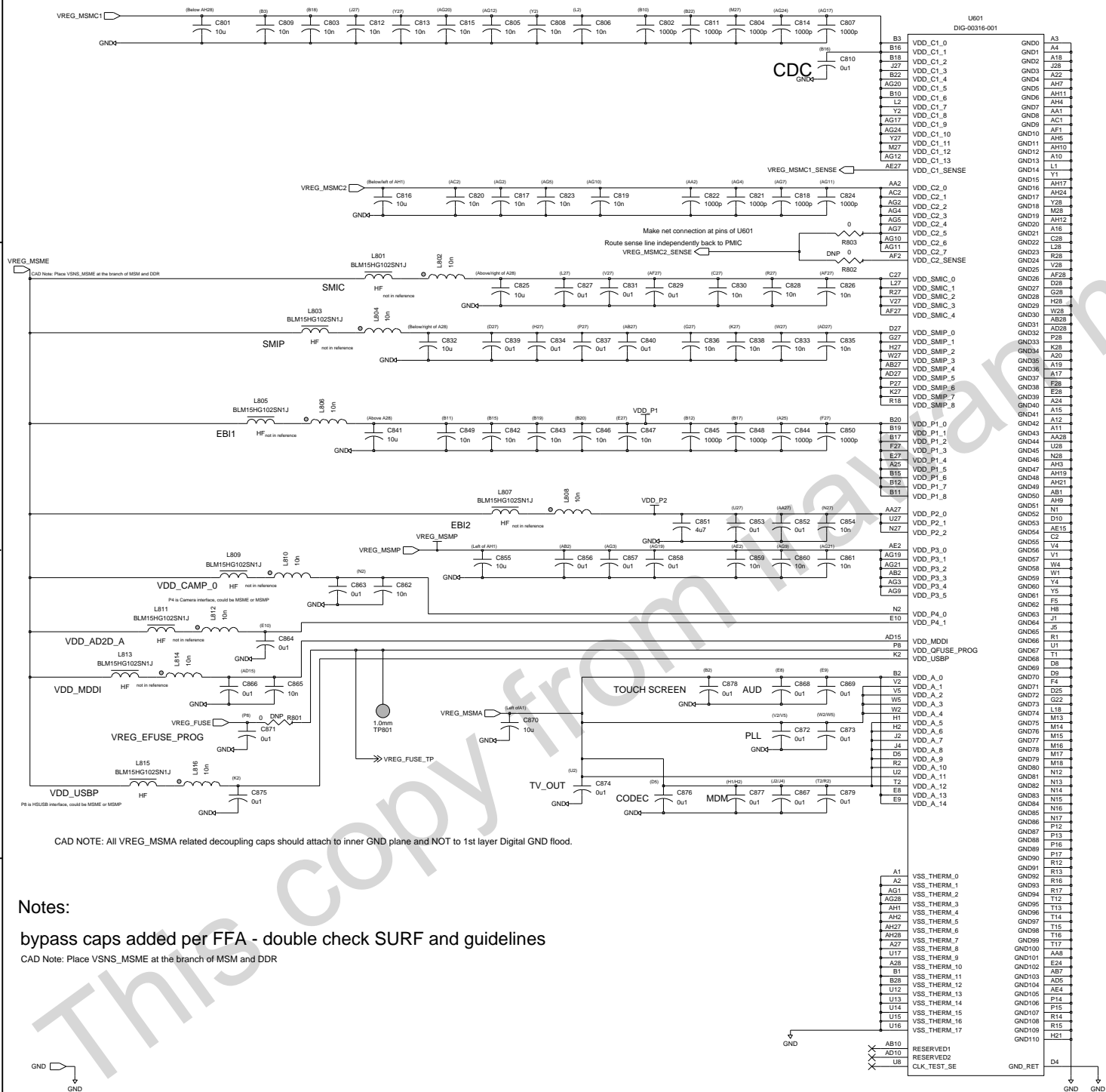

B3	VDD_C1_0
B16	VDD_C1_1
B18	VDD_C1_2
Z27	VDD_C1_3
B22	VDD_C1_4
AG20	VDD_C1_5
B10	VDD_C1_6
L2	VDD_C1_7
Y2	VDD_C1_8
AG17	VDD_C1_9
AG24	VDD_C1_10
Y27	VDD_C1_11
M27	VDD_C1_12
AG12	VDD_C1_13
AE27	VDD_C1_SENSE
AA2	VDD_C2_0
AC2	VDD_C2_1
AG2	VDD_C2_2
AG4	VDD_C2_3
AG5	VDD_C2_4
AG7	VDD_C2_5
AG10	VDD_C2_6
AG11	VDD_C2_7
AF2	VDD_C2_SENSE
C27	VDD_SMIC_0
L27	VDD_SMIC_1
R27	VDD_SMIC_2
V27	VDD_SMIC_3
AF27	VDD_SMIC_4
D27	VDD_SMIP_0
G27	VDD_SMIP_1
H27	VDD_SMIP_2
W27	VDD_SMIP_3
AB27	VDD_SMIP_4
AD27	VDD_SMIP_5
P27	VDD_SMIP_6
K27	VDD_SMIP_7
R18	VDD_SMIP_8
B20	VDD_P1_0
B19	VDD_P1_1
B17	VDD_P1_2
F27	VDD_P1_3
E27	VDD_P1_4
A25	VDD_P1_5
B15	VDD_P1_6
B12	VDD_P1_7
B11	VDD_P1_8
AA27	VDD_P2_0
U27	VDD_P2_1
N27	VDD_P2_2
AE2	VDD_P3_0
AG19	VDD_P3_1
AG21	VDD_P3_2
AB2	VDD_P3_3
AG3	VDD_P3_4
AG9	VDD_P3_5
E10	VDD_P4_0
AD15	VDD_P4_1
F8	VDD_MDDI
K2	VDD_QFUSE_PROG
B2	VDD_A_0
V2	VDD_A_1
W5	VDD_A_2
W2	VDD_A_3
H1	VDD_A_4
H2	VDD_A_5
J2	VDD_A_7
J4	VDD_A_8
R2	VDD_A_9
U2	VDD_A_10
T2	VDD_A_11
E8	VDD_A_12
E9	VDD_A_13
E9	VDD_A_14
A1	VSS_THERM_0
A2	VSS_THERM_1
AG1	VSS_THERM_2
AG28	VSS_THERM_3
AH1	VSS_THERM_4
AH2	VSS_THERM_5
AH27	VSS_THERM_6
AK28	VSS_THERM_7
A27	VSS_THERM_8
U17	VSS_THERM_9
U18	VSS_THERM_10
B1	VSS_THERM_11
B28	VSS_THERM_12
U12	VSS_THERM_13
U13	VSS_THERM_14
U14	VSS_THERM_15
U15	VSS_THERM_16
U16	VSS_THERM_17
AB10	RESERVED1
AD10	RESERVED2
UB	CLK_TEST_SE

GND0	A3
GND1	A4
GND2	A18
GND3	Z28
GND4	A22
GND5	AH7
GND6	AH11
GND7	AH4
GND8	AA1
GND9	AC1
GND10	AF1
GND11	AH5
GND12	AH10
GND13	A10
GND14	L1
GND15	AH17
GND16	AH24
GND17	Y28
GND18	N28
GND19	AH12
GND20	AH12
GND21	A16
GND22	C28
GND23	L28
GND24	R28
GND25	V28
GND26	AF28
GND27	G28
GND28	H28
GND29	V28
GND30	AF28
GND31	AD28
GND32	AH28
GND33	P28
GND34	K28
GND35	A28
GND36	A19
GND37	A17
GND38	F28
GND39	A24
GND40	A15
GND41	A15
GND42	A12
GND43	AA28
GND44	U28
GND45	U28
GND46	N28
GND47	AH19
GND48	AH3
GND49	AH21
GND50	AB1
GND51	AH9
GND52	N1
GND53	D10
GND54	AE15
GND55	C2
GND56	V4
GND57	V1
GND58	V4
GND59	W1
GND60	Y4
GND61	Y5
GND62	F5
GND63	H8
GND64	J1
GND65	J5
GND66	R1
GND67	T1
GND68	D8
GND69	D9
GND70	F4
GND71	D25
GND72	G22
GND73	L18
GND74	N13
GND75	M14
GND76	M15
GND77	M16
GND78	M17
GND79	M18
GND80	N12
GND81	N12
GND82	N13
GND83	N14
GND84	N15
GND85	N16
GND86	N17
GND87	P12
GND88	P13
GND89	P16
GND90	P17
GND91	R12
GND92	R13
GND93	R16
GND94	R17
GND95	T12
GND96	T13
GND97	T14
GND98	T15
GND99	T16
GND100	T17
GND101	AA8
GND102	E24
GND103	AD5
GND104	AE4
GND105	P14
GND106	P15
GND107	R14
GND108	R15
GND109	R15
GND110	H21
GND	D4

Notes:
 bypass caps added per FFA - double check SURF and guidelines
 CAD Note: Place VSNS_MSME at the branch of MSM and DDR

RESEARCH IN MOTION CONFIDENTIAL	
HIERARCHICAL BLOCK PROCESSOR3	COPYRIGHT 2008, RESEARCH IN MOTION LIMITED 295 PHILLIP ST. WATERLOO, ONTARIO, CANADA PHONE: (519) 888-7465, FAX (519) 888-6306
DRAWN BY Raman Sharma	TITLE Niagara - China Telecom
R&D CHECK	(uses: PCB-20335-005)
IFG CHECK	SIZE DRAWING No. SCH-31764-001
Edi Led Bu: dwelling	REV 1A
Last Ed1: Sep 2, 2008, 11:41:30 am	SHEET 8 OF 16

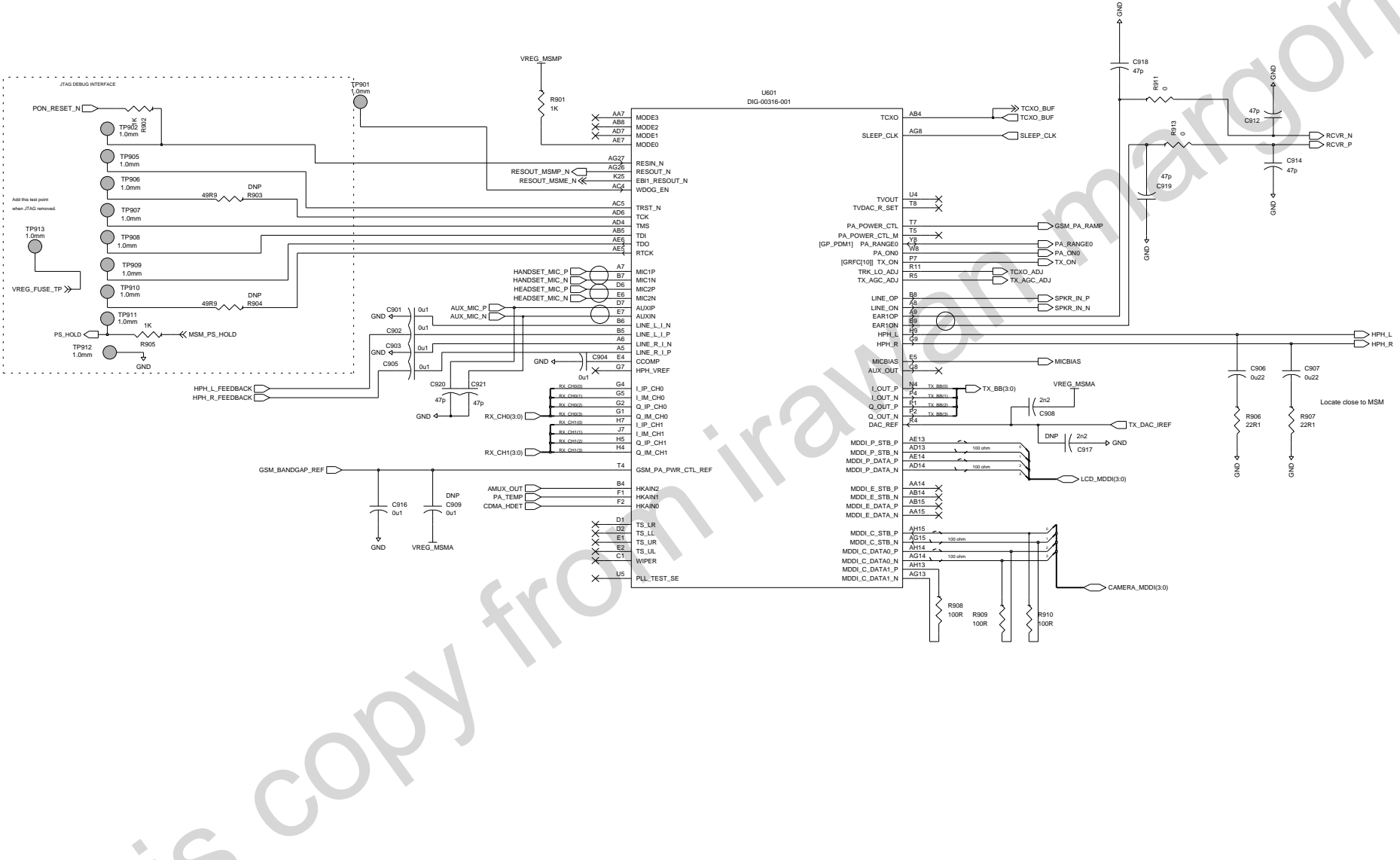

RESEARCH IN MOTION CONFIDENTIAL

HIERARCHICAL BLOCK PROCESSOR4		COPYRIGHT 2008, RESEARCH IN MOTION LIMITED 295 PHILLIP ST. WATERLOO, ONTARIO, CANADA PHONE: (519) 888-7465, FAX (519) 888-6306	
DRAWN BY Raman Sharma		TITLE Niagara - China Telecom (uses: PCB-20335-005)	
R&D CHECK		SIZE DRAWING No. SCH-31764-001	
MFG CHECK		C REV 1A SHEET 9 OF 16	
Edi Led By: dwelling		Date: 4, 2008, 4:01:00 pm	

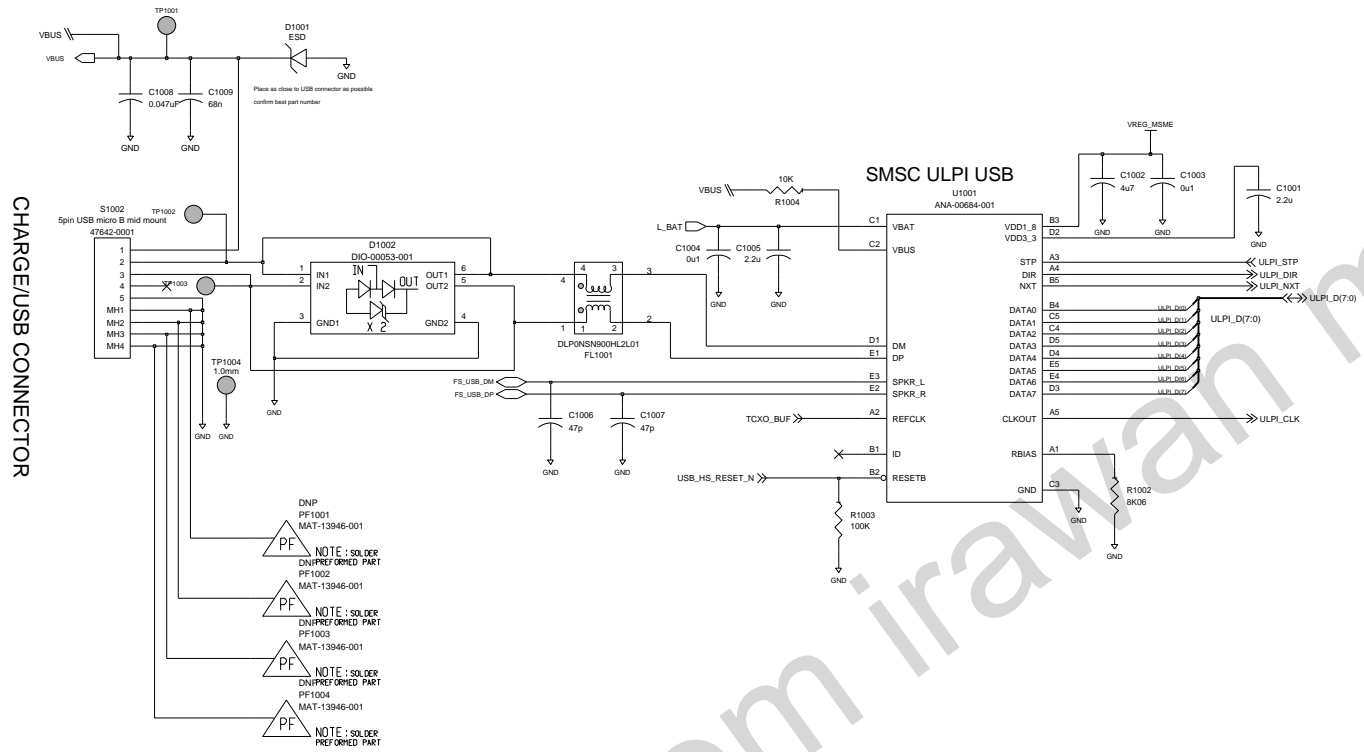

CHARGE/USB CONNECTOR

- DNP PF1001 MAT-13946-001
- NOTE : SOLDER DNP/PREFERRED PART
- PF1002 MAT-13946-001
- NOTE : SOLDER DNP/PREFERRED PART
- PF1003 MAT-13946-001
- NOTE : SOLDER DNP/PREFERRED PART
- PF1004 MAT-13946-001
- NOTE : SOLDER PREFERRED PART

RESEARCH IN MOTION CONFIDENTIAL

HIERARCHICAL BLOCK PROCESSORS		COPYRIGHT 2008, RESEARCH IN MOTION LIMITED 295 PHILLIP ST. WATERLOO, ONTARIO, CANADA PHONE: (519) 888-7465, FAX (519) 888-6306	
DRAWN BY: Raman Sharma		TITLE Niagara - China Telecom (uses: PCB-20335-005)	
R&D CHECK		SIZE DRAWING No. SCH-31764-001	
MFG CHECK		C REV 1A SHEET 10 OF 16	
Edi Led Bu: dwelling		Level: Ed14: Nov 11, 2008, 8:39:51 am	

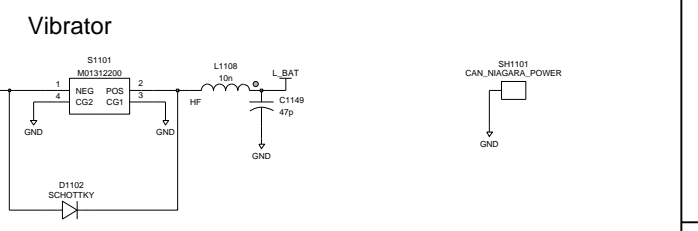
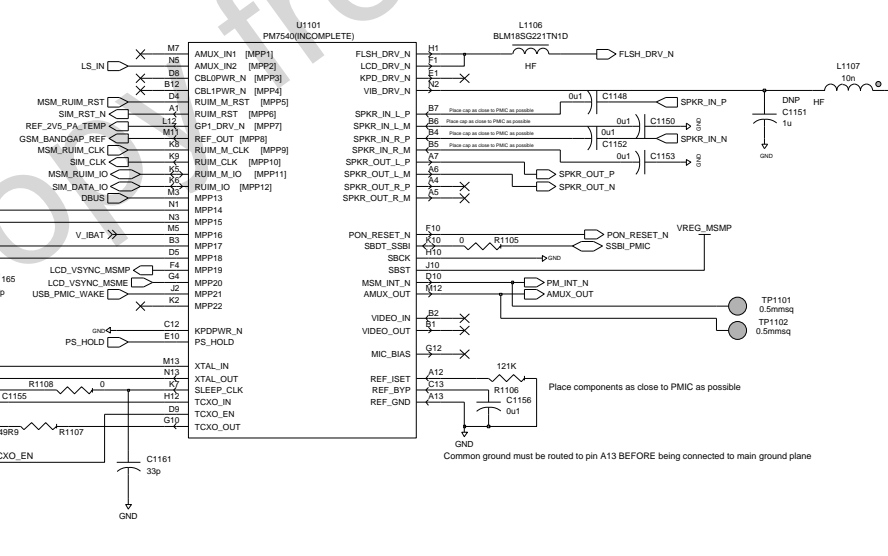
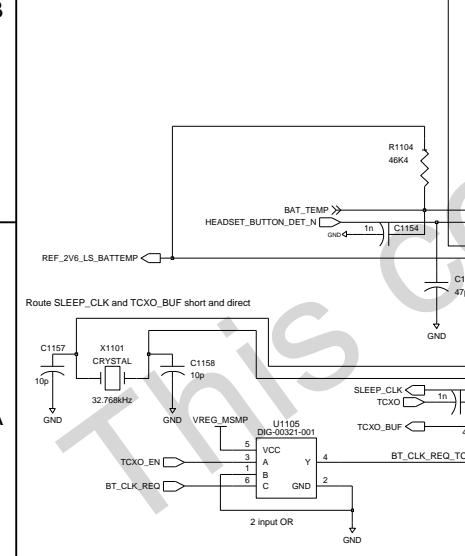
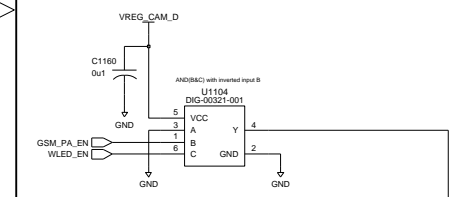
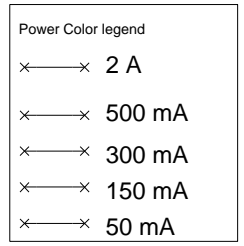
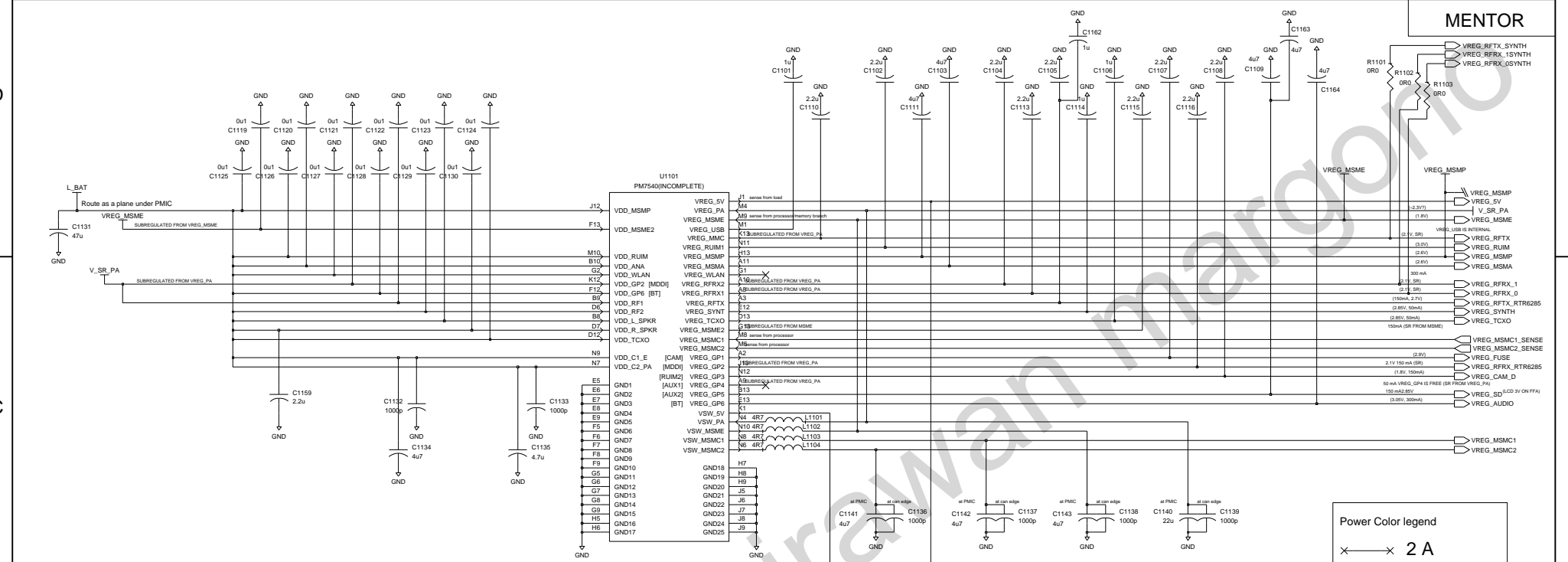

RESEARCH IN MOTION CONFIDENTIAL

HIERARCHICAL BLOCK POWER2	COPYRIGHT 2009, RESEARCH IN MOTION LIMITED 295 PHILLIP ST. WATERLOO, ONTARIO, CANADA PHONE: (519) 888-7465, FAX (519) 888-6306
DRAWN BY Raman Sharma	TITLE Niagara - China Telecom (uses: PCB-20335-005)
R&D CHECK	SIZE DRAWING No. SCH-31764-001
HFG CHECK	C REV 1A SHEET 11 OF 16
Edi Led Bu: dwelling	
Level: Ed1: Jan 19, 2009, 3:12:27 pm	

D

D

C

C

B

B

A

A

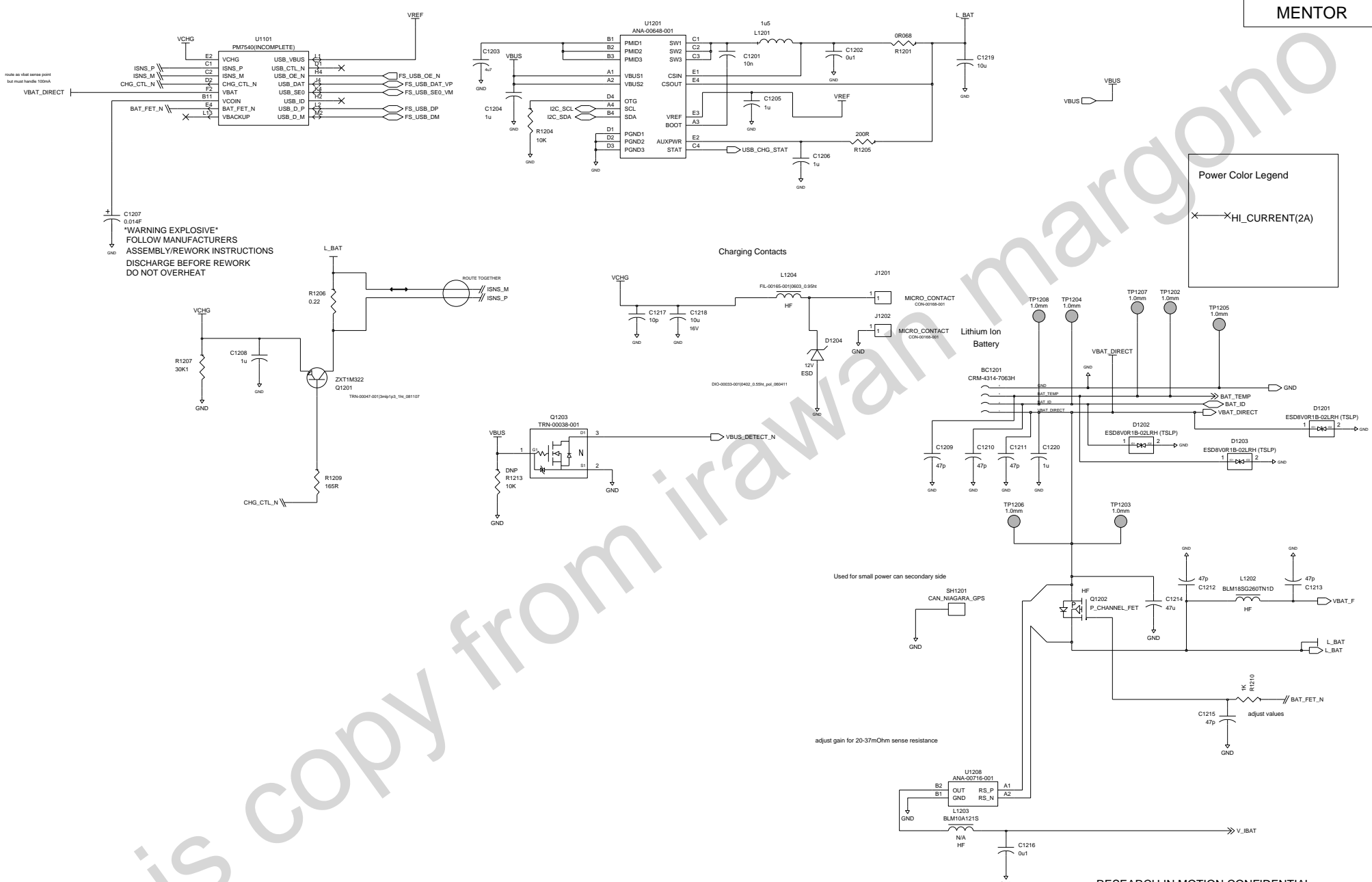

RESEARCH IN MOTION CONFIDENTIAL

HIERARCHICAL BLOCK POWER22		COPYRIGHT 2008, RESEARCH IN MOTION LIMITED 295 PHILLIP ST. WATERLOO, ONTARIO, CANADA PHONE: (519) 888-7465, FAX (519) 888-6306	
DRAWN BY Raman Sharma		TITLE Niagara - China Telecom (uses: PCB-20335-005)	
R&D CHECK		SIZE DRAWING No. SCH-31764-001	
MFG CHECK		C REV 1A SHEET 12 OF 16	
Edi Led By: moonsh		Label Ed1: Dec 11, 2008, 9:25:45 am	

TRACK BALL CONNECTOR

LCD CONNECTOR

RESEARCH IN MOTION CONFIDENTIAL

HIERARCHICAL BLOCK INTERFACE		COPYRIGHT 2000, RESEARCH IN MOTION LIMITED 295 PHILLIP ST. WATERLOO, ONTARIO, CANADA PHONE: (519) 888-7465, FAX (519) 888-6306	
DRAWN BY: Raman Sharma		TITLE: Niagara - China Telecom	
R&D CHECK		(uses: PCB-20335-005)	
MFG CHECK		SIZE: DRAWING No. BCH-31764-001	
Edi Led Bu: dwelling		C REV 1A SHEET 13 OF 16	
Last Ed1: May 26, 2009, 11:50:31 am			

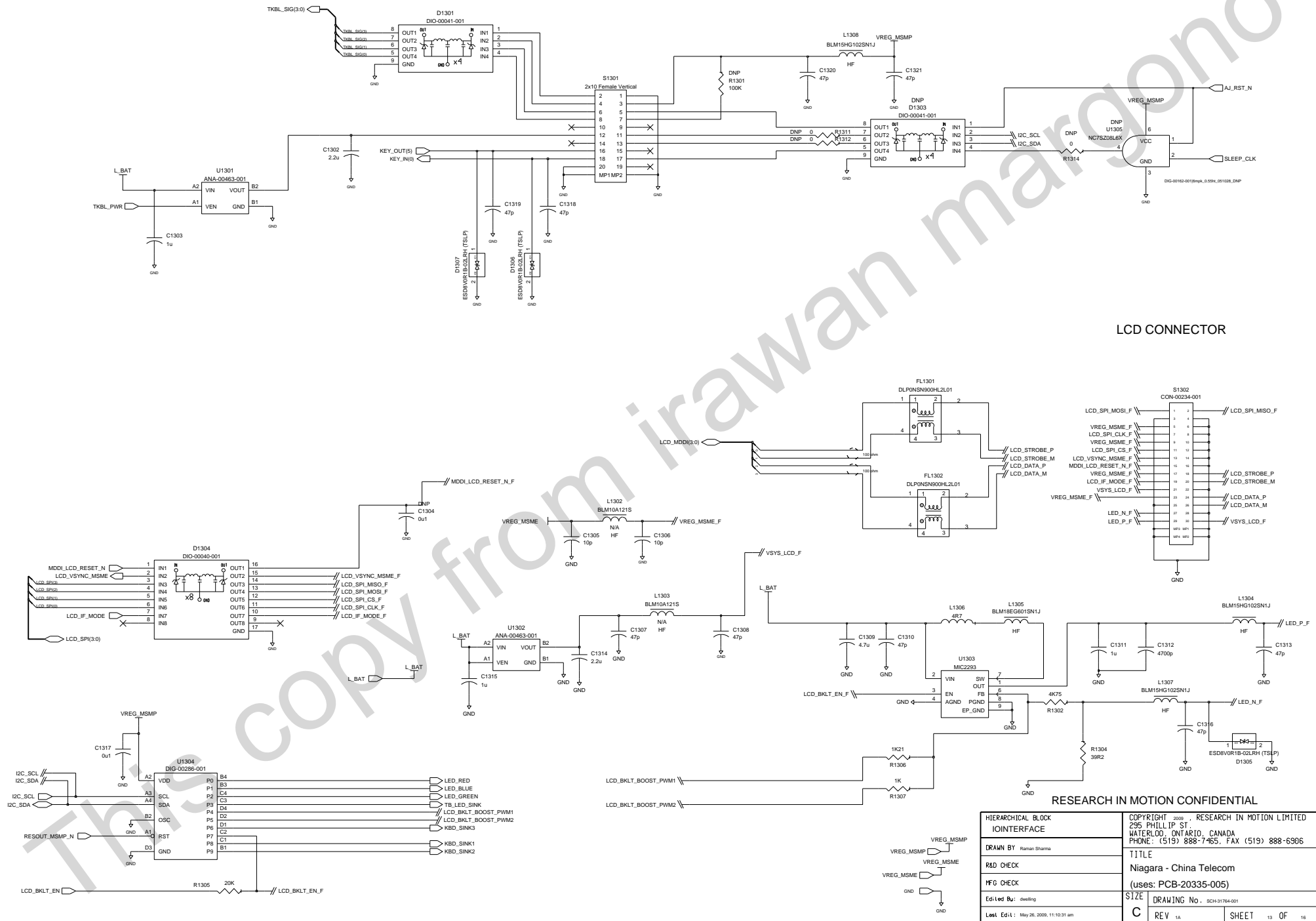

4

3

2

1

4

3

2

1

D

D

C

C

B

B

A

A

BLUETOOTH ANT. Clip

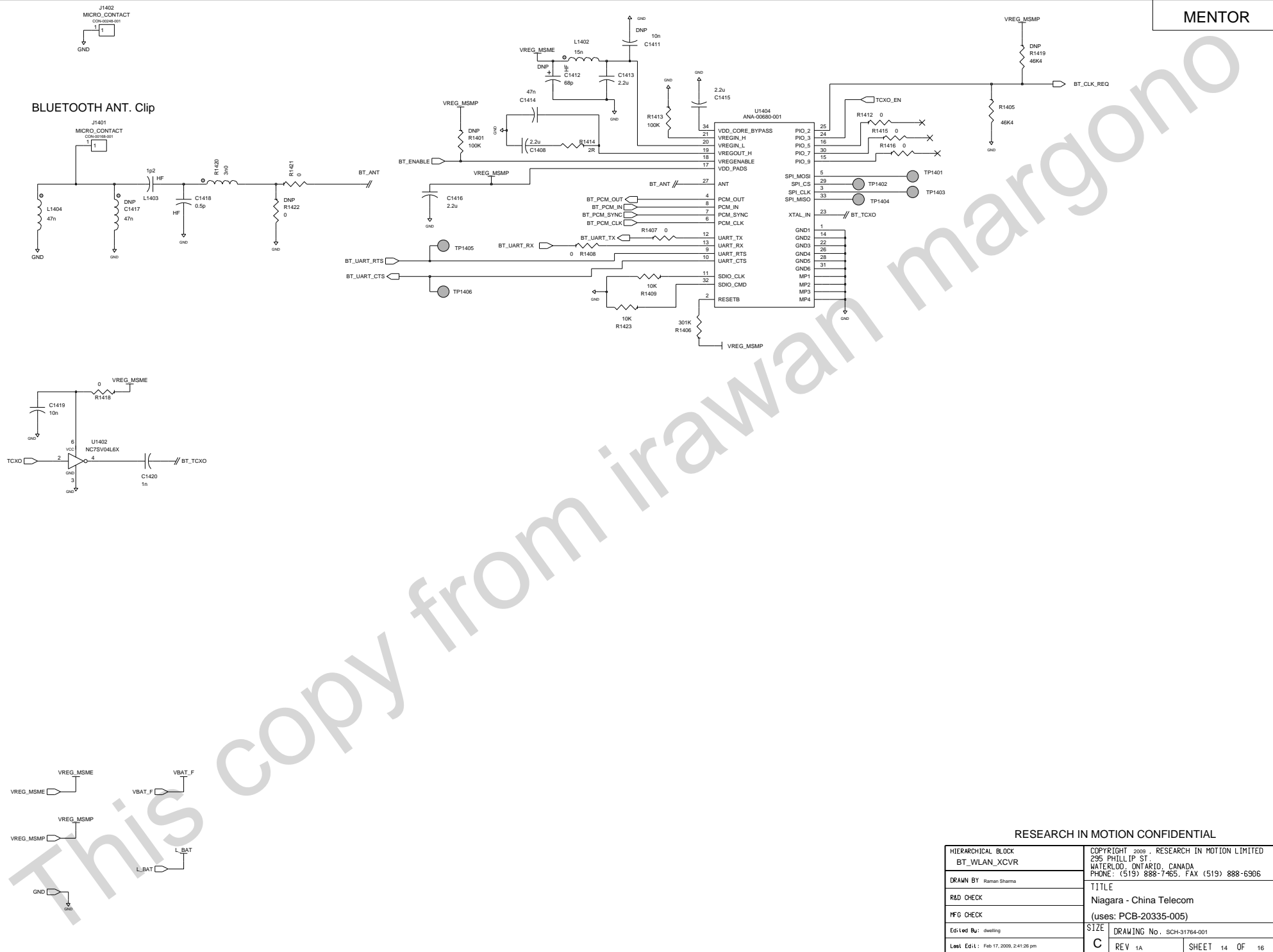

RESEARCH IN MOTION CONFIDENTIAL

HIERARCHICAL BLOCK BT_WLAN_XCVR		COPYRIGHT 2009, RESEARCH IN MOTION LIMITED 295 PHILLIP ST. WATERLOO, ONTARIO, CANADA PHONE: (519) 888-7465, FAX (519) 888-6306	
DRAWN BY: Raman Sharma		TITLE Niagara - China Telecom (uses: PCB-20335-005)	
R&D CHECK		SIZE DRAWING No. SCH-31764-001	
MFG CHECK		C REV 1A SHEET 14 OF 16	
Edi Led By: dwelling		Level: Ed14: Feb 17, 2009, 2:41:26 pm	

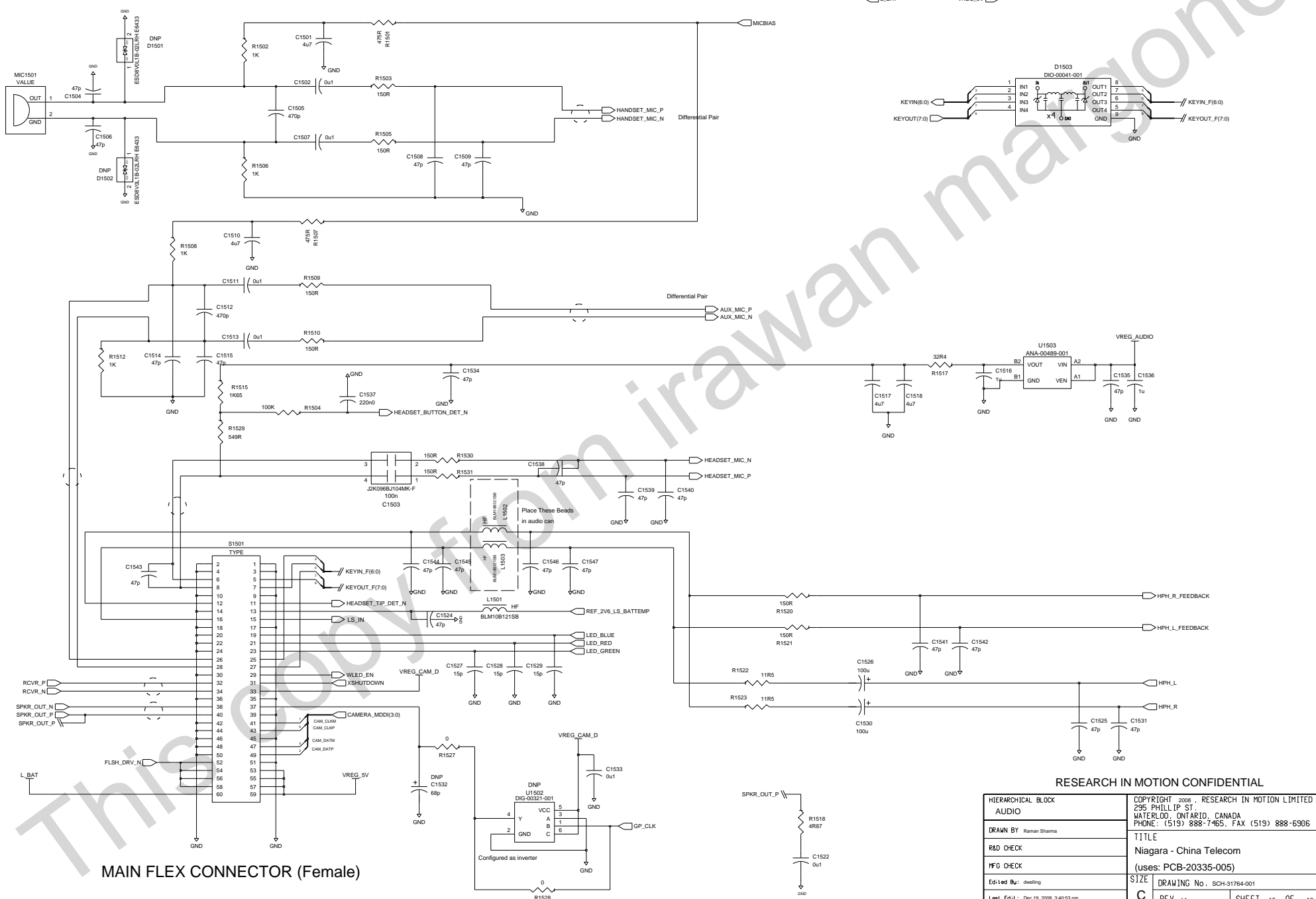

RESEARCH IN MOTION CONFIDENTIAL

HIERARCHICAL BLOCK AUDIO		COPYRIGHT 2008, RESEARCH IN MOTION LIMITED 295 PHILLIP ST. WATERLOO, ONTARIO, CANADA PHONE: (519) 888-7465, FAX (519) 888-6306	
DRAWN BY Raman Sharma		TITLE Niagara - China Telecom	
R&D CHECK		(uses: PCB-20335-005)	
MFG CHECK		SIZE DRAWING No. SCH-31764-001	
Edi Led Bu: dwelling		C REV 1A SHEET 15 OF 16	
Level Edi L: Dec 19, 2008, 3:40:53 pm			

MAIN FLEX CONNECTOR (Female)

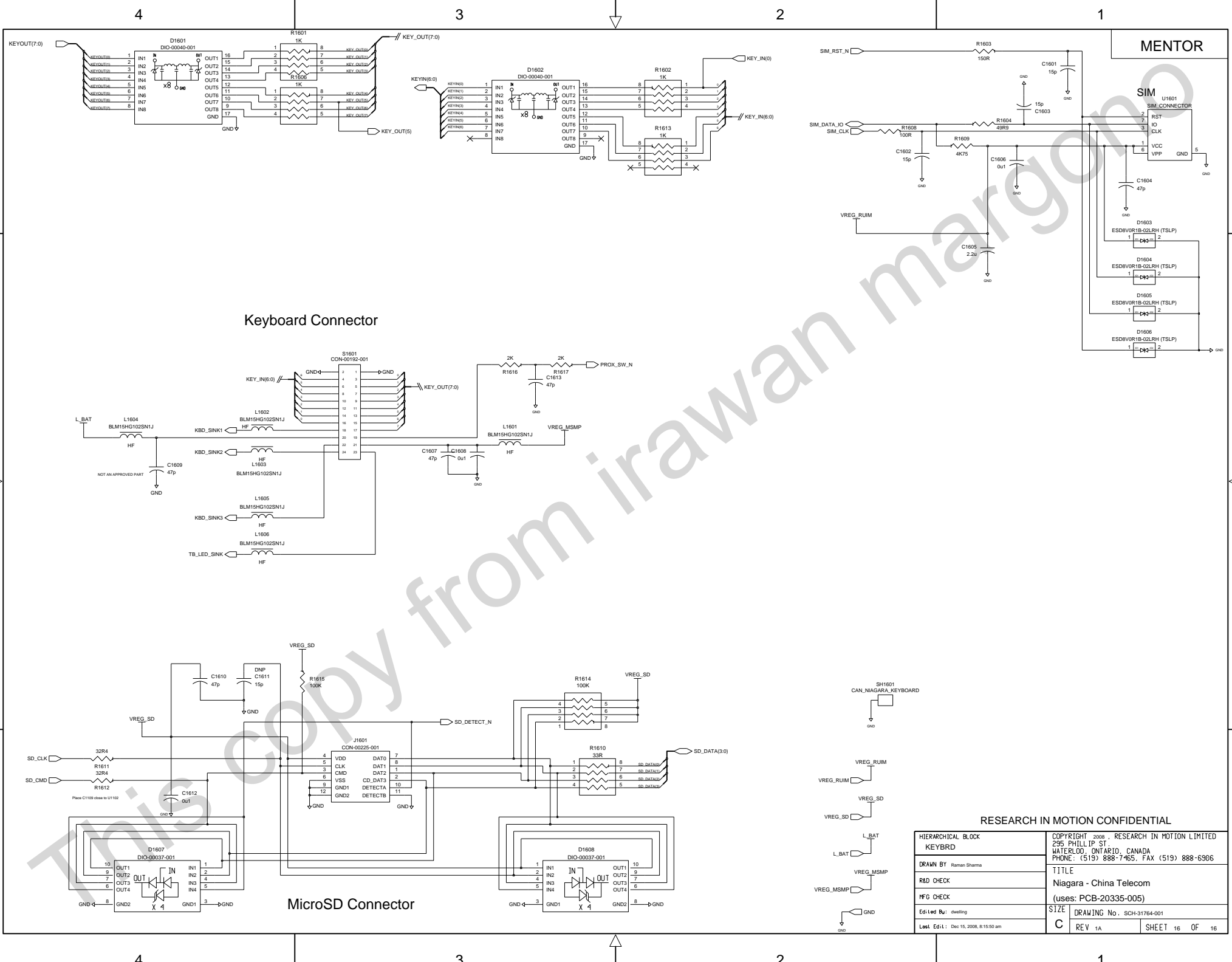

Keyboard Connector

MicroSD Connector

RESEARCH IN MOTION CONFIDENTIAL

HIERARCHICAL BLOCK KEYBRD		COPYRIGHT 2008, RESEARCH IN MOTION LIMITED 295 PHILLIP ST. WATERLOO, ONTARIO, CANADA PHONE: (519) 888-7465, FAX (519) 888-6306	
DRAWN BY Raman Sharma		TITLE Niagara - China Telecom (uses: PCB-20335-005)	
R&D CHECK		SIZE DRAWING No. SCH-31764-001	
MFG CHECK		C REV 1A SHEET 16 OF 16	
Edi Led Bu: dwelling		Level: Ed1:1 Date: 15, 2008, 8:15:50 am	