

RESEARCH IN MOTION CONFIDENTIAL

HIERARCHICAL BLOCK MAIN	COPYRIGHT 2009, RESEARCH IN MOTION LIMITED 295 PHILLIP ST. WATERLOO, ONTARIO, CANADA PHONE: (519) 888-7465, FAX (519) 888-6306
DRAWN BY Louis Rodriguez	TITLE Odin
R&D CHECK	(uses PCB-21648-007)
HFG CHECK	SIZE DRAWING No. SCH-21649-007
Edi Led Bu: itrodigu	C REV 1A SHEET 1 OF 19
Level Ed1: Aug 21, 2009, 12:01:07 pm	

D

D

C

C

B

B

A

A

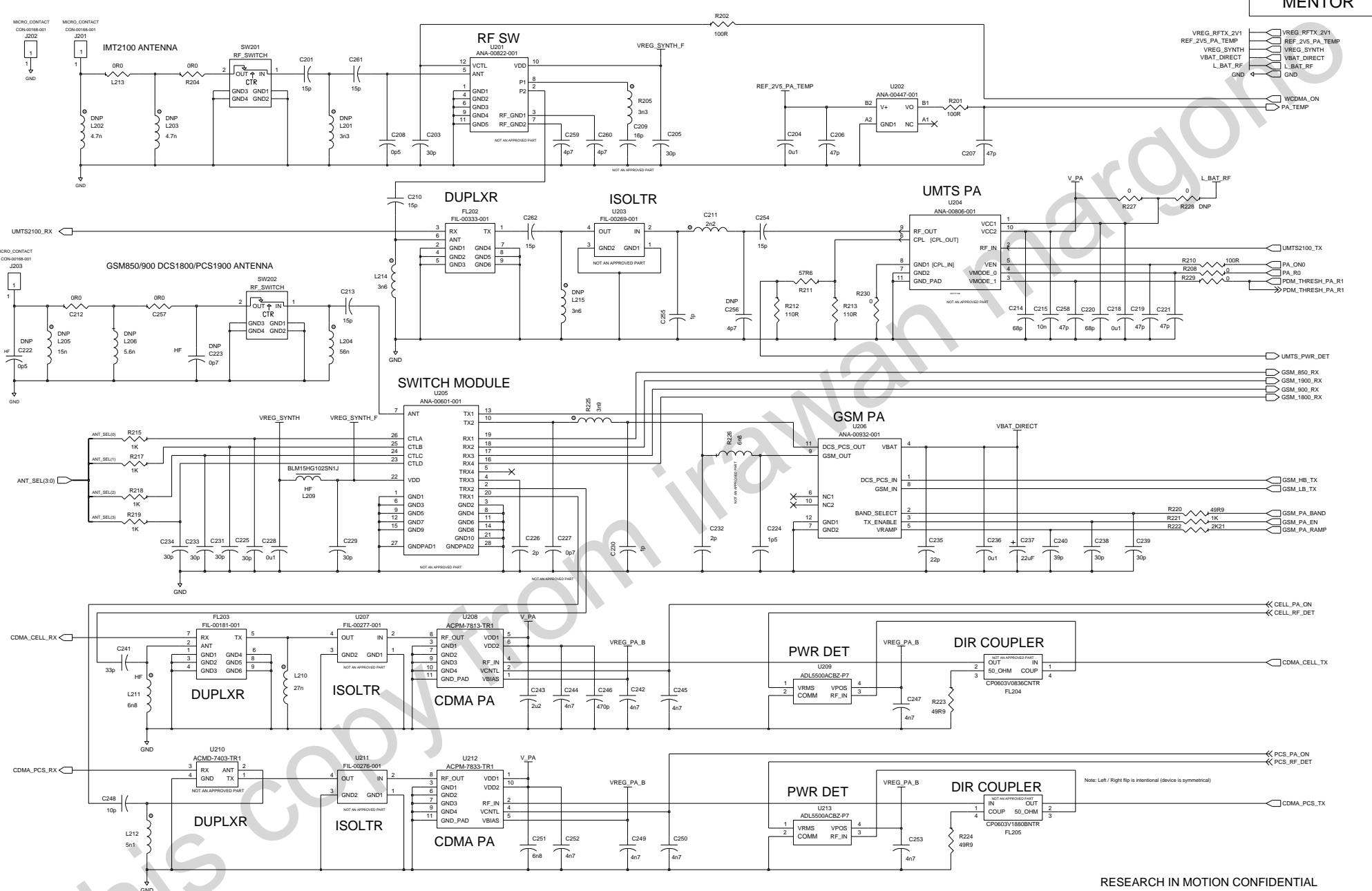

RESEARCH IN MOTION CONFIDENTIAL

HIERARCHICAL BLOCK RF_ANT		COPYRIGHT 2009, RESEARCH IN MOTION LIMITED 295 PHILLIP ST. WATERLOO, ONTARIO, CANADA PHONE: (519) 888-7465, FAX (519) 888-6306	
DRAWN BY: Louis Rodriguez		TITLE Odin (uses PCB-21648-007)	
R&D CHECK		SIZE DRAWING No. SCH-21649-007	
MFG CHECK		C REV 1A SHEET 2 OF 19	
Edi Led Bu: Irodru		Label: Ed14: Aug 21, 2009, 12:06:34 pm	

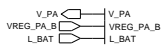

CDMA

2.6V LIN REG

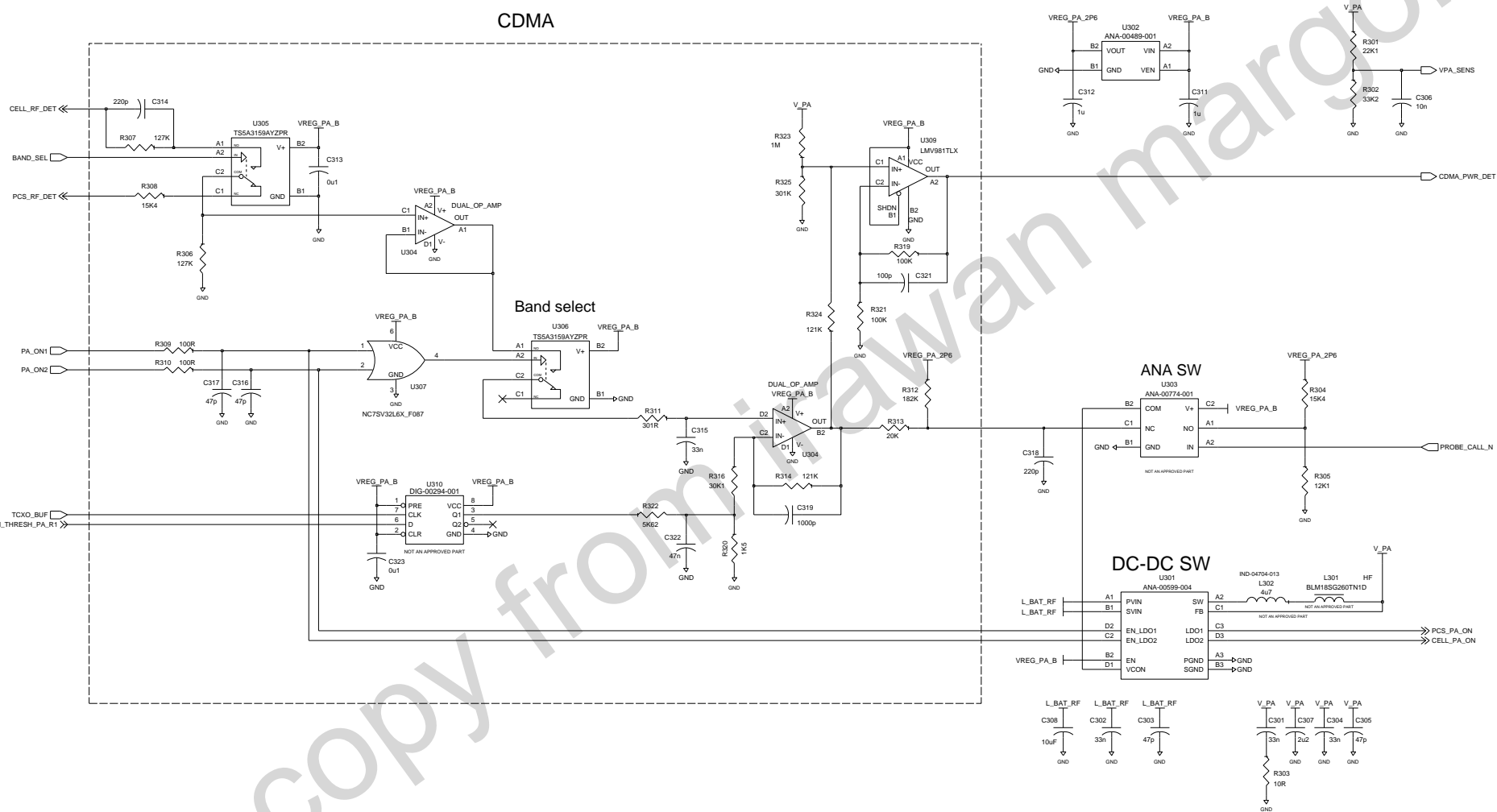

RESEARCH IN MOTION CONFIDENTIAL

HIERARCHICAL BLOCK RF_ANT2		COPYRIGHT 2009, RESEARCH IN MOTION LIMITED 295 PHILLIP ST. WATERLOO, ONTARIO, CANADA PHONE: (519) 888-7465, FAX (519) 888-6306	
DRAWN BY: Louis Rodriguez		TITLE Odin (uses PCB-21648-007)	
R&D CHECK		SIZE C	
MFG CHECK		DRAWING No. SCH-21649-007	
Ed: Led Bu: Irodigu		REV 1A SHEET 3 OF 19	
Label Ed: 11 Aug 21, 2009, 12:10:14 pm			

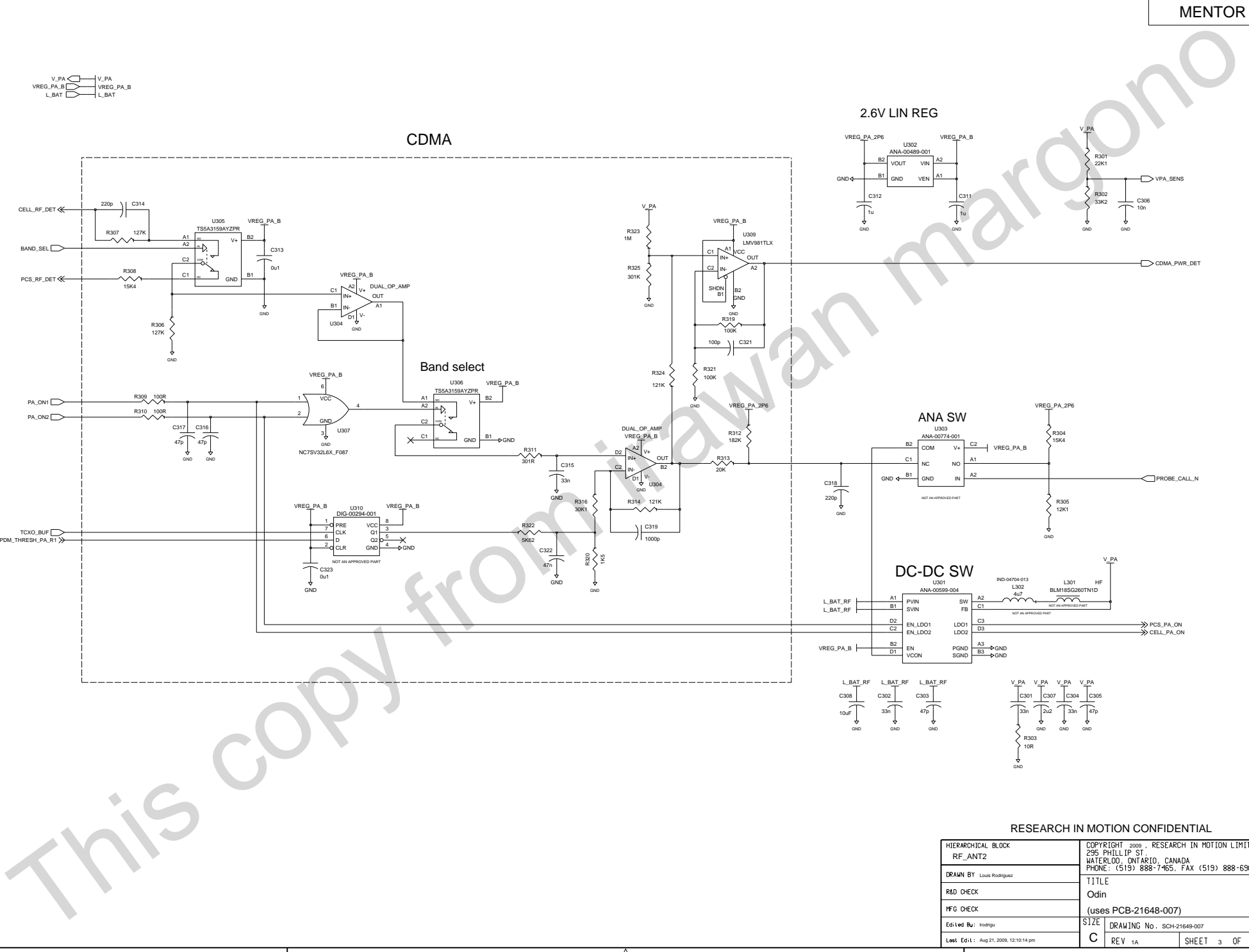

D

D

C

C

B

B

A

A

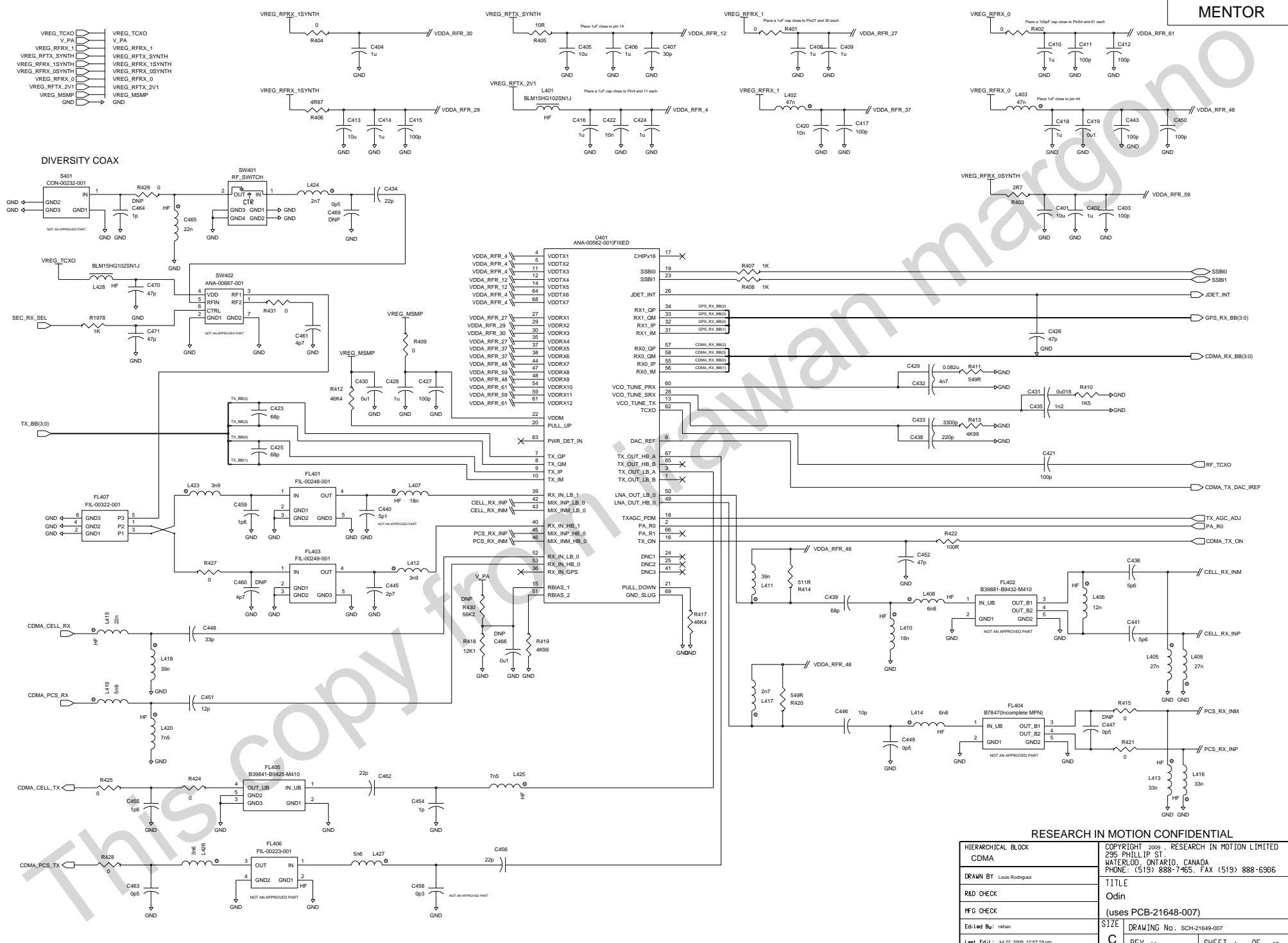

RESEARCH IN MOTION CONFIDENTIAL

<b>HIERARCHICAL BLOCK</b>		<b>COPYRIGHT</b> 2009, RESEARCH IN MOTION LIMITED 295 PHILLIP ST. WATERLOO, ONTARIO, CANADA PHONE: (519) 888-7465, FAX (519) 888-6306	
<b>DRAWN BY</b>	Louis Rodriguez	<b>TITLE</b>	Odin
<b>R&amp;D CHECK</b>		<b>FIG CHECK</b>	(uses PCB-21648-007)
<b>Edi Led By:</b>	rshan	<b>SIZE</b>	DRAWING No. SCH-21649-007
<b>Label</b>	Edi 1 Jul 22, 2009, 12:57:19 pm	<b>C</b>	REV 1A SHEET 4 OF 19

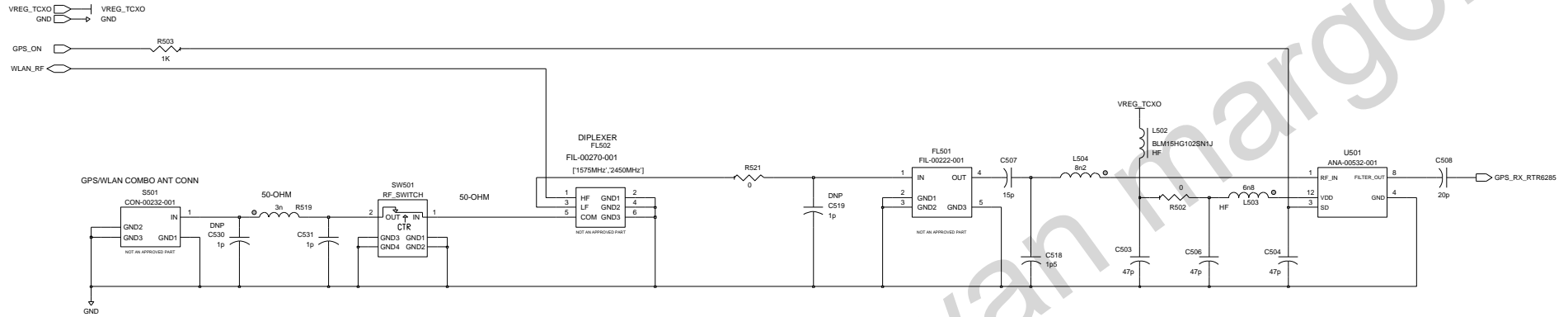

GPS

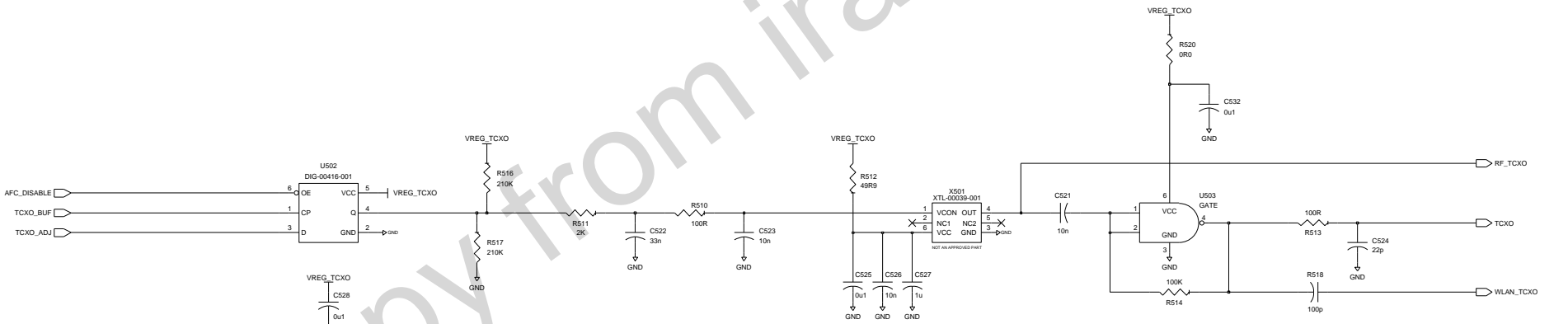

TCXO

RESEARCH IN MOTION CONFIDENTIAL

HIERARCHICAL BLOCK GPS_TCXO		COPYRIGHT 2009, RESEARCH IN MOTION LIMITED 295 PHILLIP ST. WATERLOO, ONTARIO, CANADA PHONE: (519) 888-7465, FAX (519) 888-6306	
DRAWN BY: Louis Rodriguez		TITLE Odin	
R&D CHECK		(uses PCB-21648-007)	
MFG CHECK		SIZE DRAWING No. SCH-21649-007	
Edi Led By: rnkhan		REV 1A SHEET 5 OF 19	
Level: Ed1: Jul 22, 2009, 2:35:26 pm			

DUAL COAX CLIP FOR  
1) COMBO GPS/WLAN CABLE  
2) DIVERSITY CABLE



HOW-23759-002@ent\_clip\_dual\_1p3m\_090306

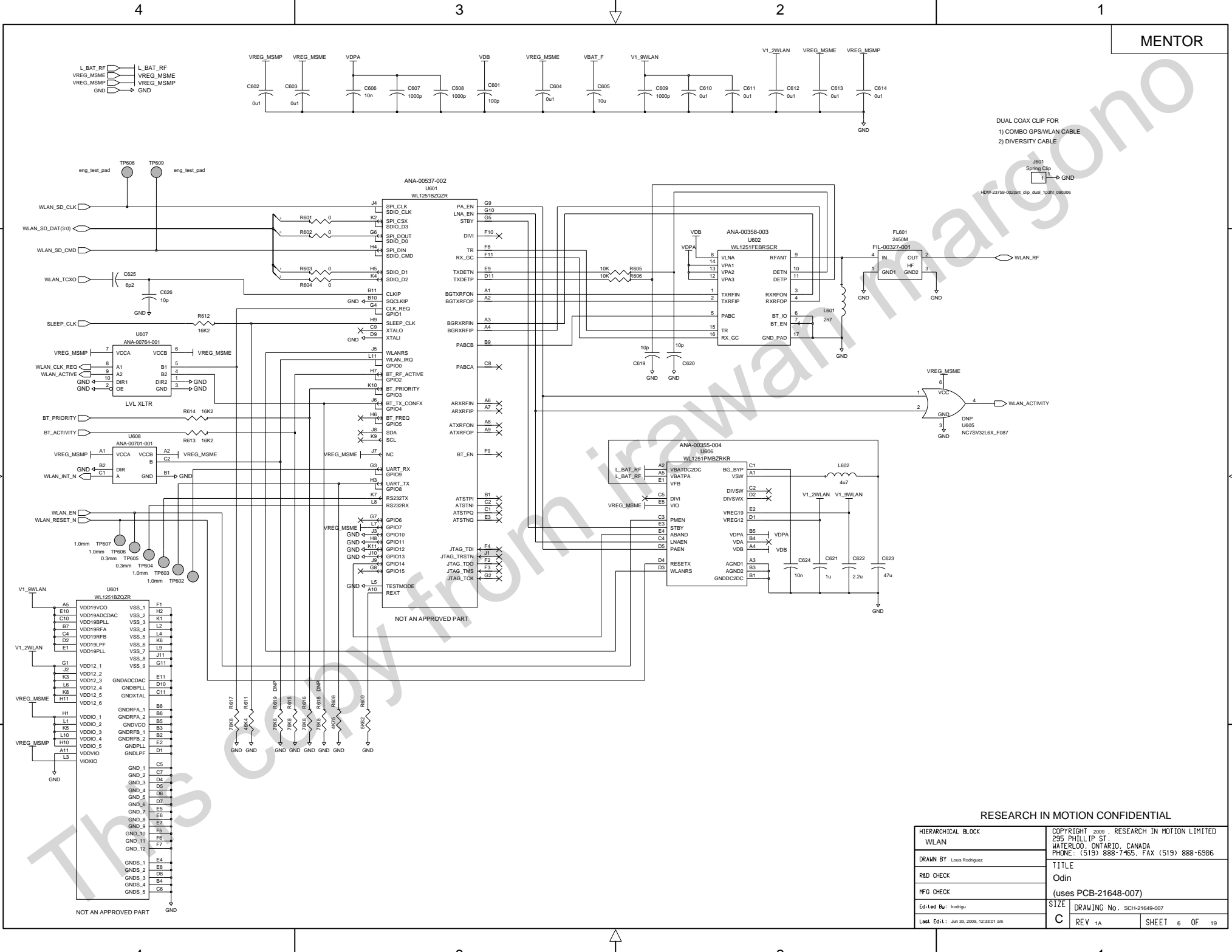

RESEARCH IN MOTION CONFIDENTIAL

HIERARCHICAL BLOCK WLAN		COPYRIGHT 2009, RESEARCH IN MOTION LIMITED 295 PHILLIP ST. WATERLOO, ONTARIO, CANADA PHONE: (519) 888-7465, FAX (519) 888-6306	
DRAWN BY: Louis Rodriguez		TITLE Odin	
R&D CHECK		(uses PCB-21648-007)	
MFG CHECK		SIZE DRAWING No. SCH-21649-007	
Edi Led Bu: Irodru		REV 1A	
Last Edt: Jun 30, 2009, 12:33:01 am		SHEET 6 OF 19	

4

3

2

1

4

3

2

1

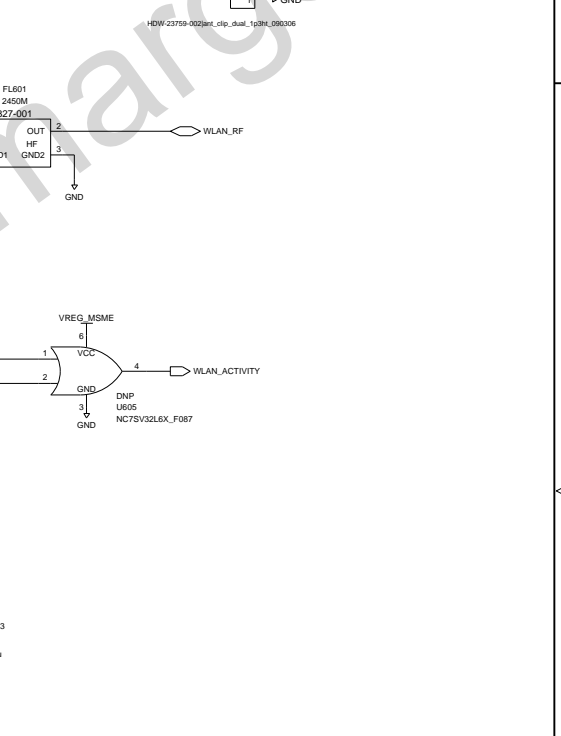
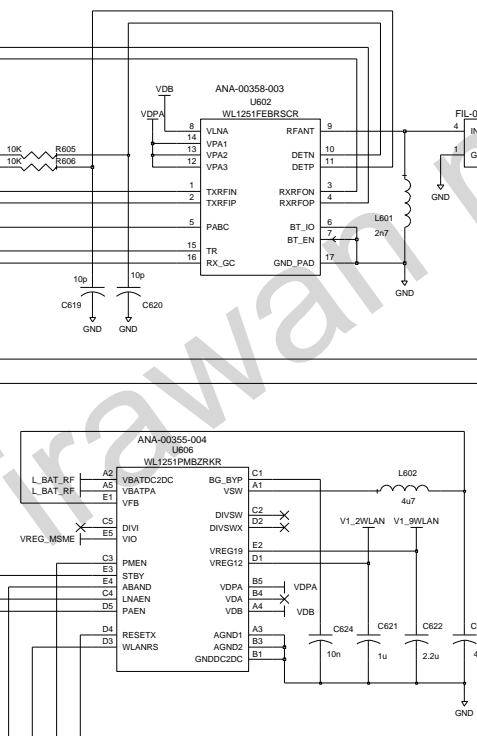
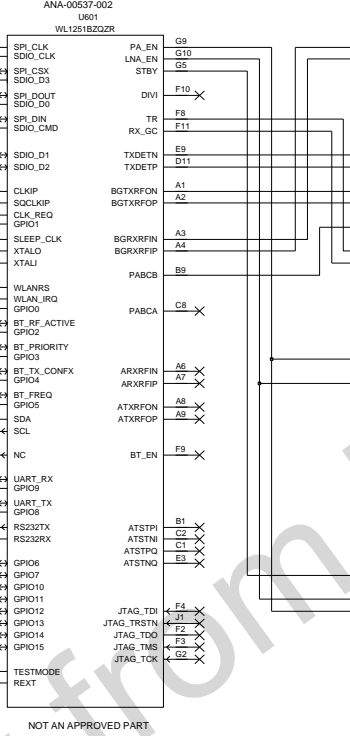
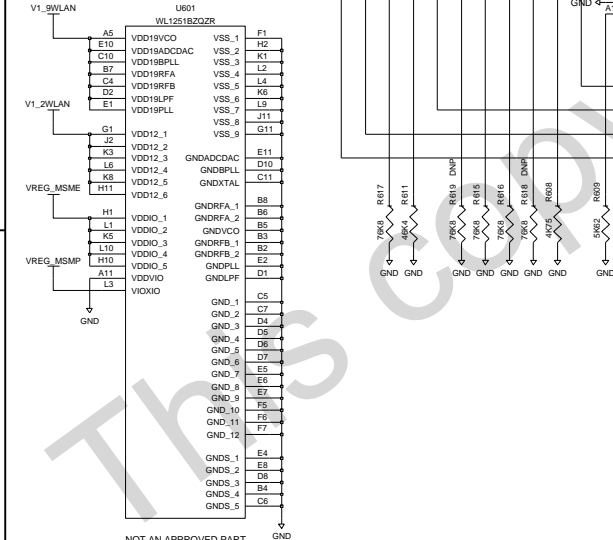
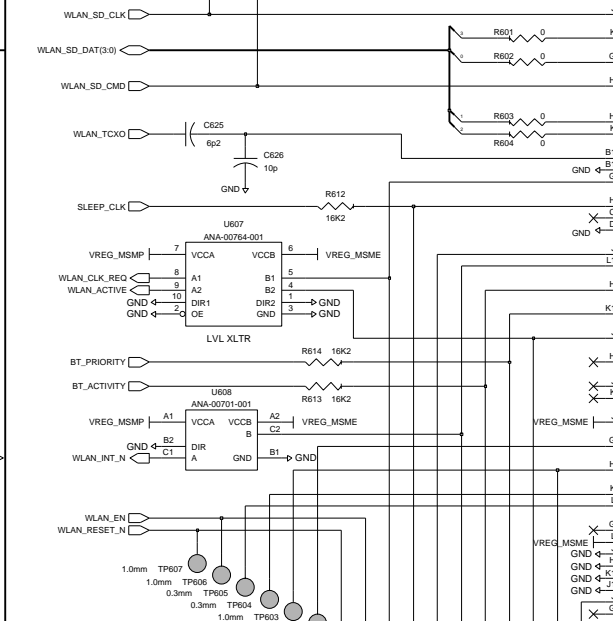
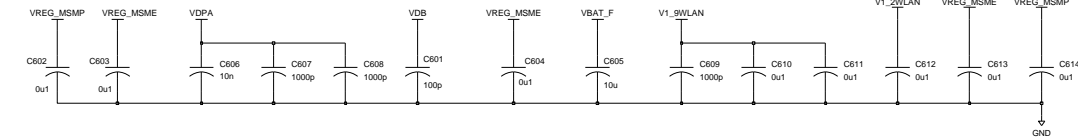
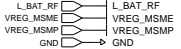

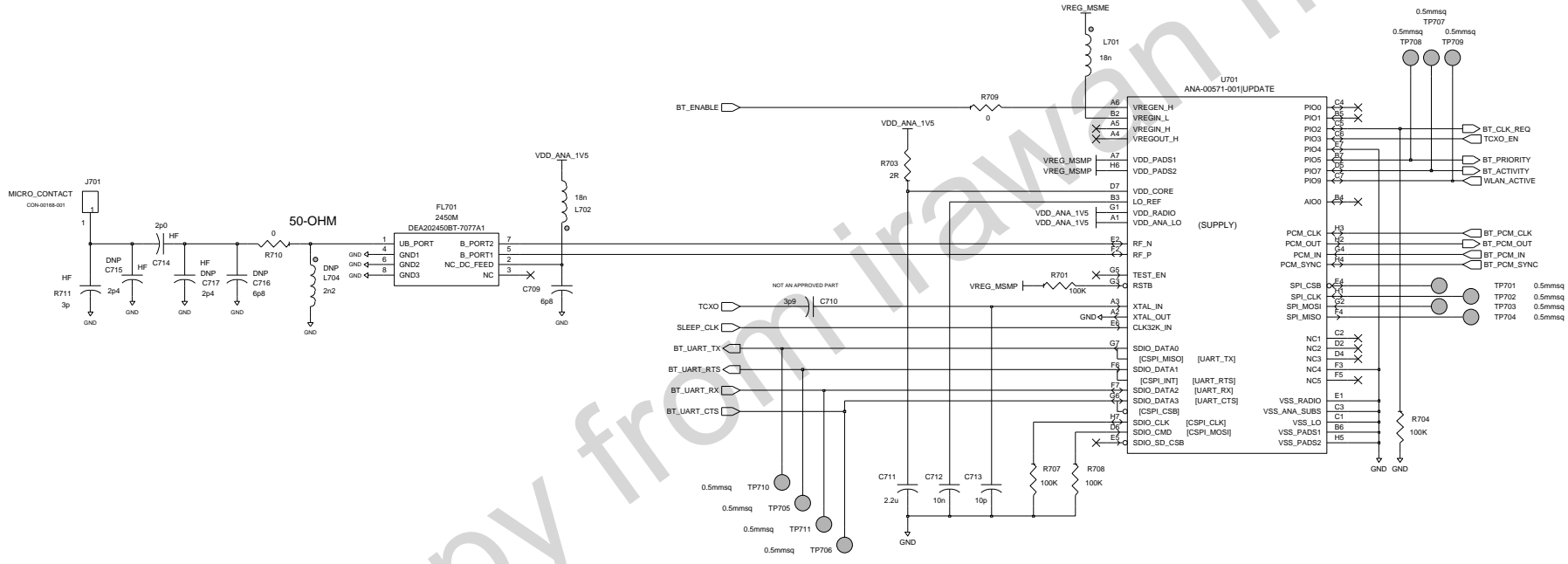
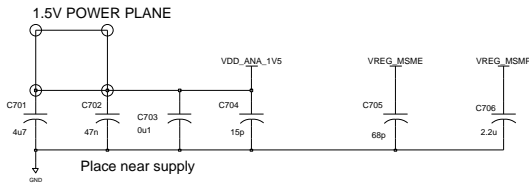
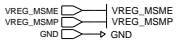

RESEARCH IN MOTION CONFIDENTIAL

HIERARCHICAL BLOCK BLUETOOTH		COPYRIGHT 2009, RESEARCH IN MOTION LIMITED 295 PHILLIP ST. WATERLOO, ONTARIO, CANADA PHONE: (519) 888-7465, FAX (519) 888-6306	
DRAWN BY: Louis Rodriguez		TITLE Odin	
R&D CHECK		(uses PCB-21648-007)	
MFG CHECK		SIZE DRAWING No. SCH-21649-007	
Edi Led By: rkhani		C	
Level: Ed1: Jul 22, 2009, 3:07:03 pm		REV 1A	SHEET 7 OF 19

D

D

C

C

B

B

A

A

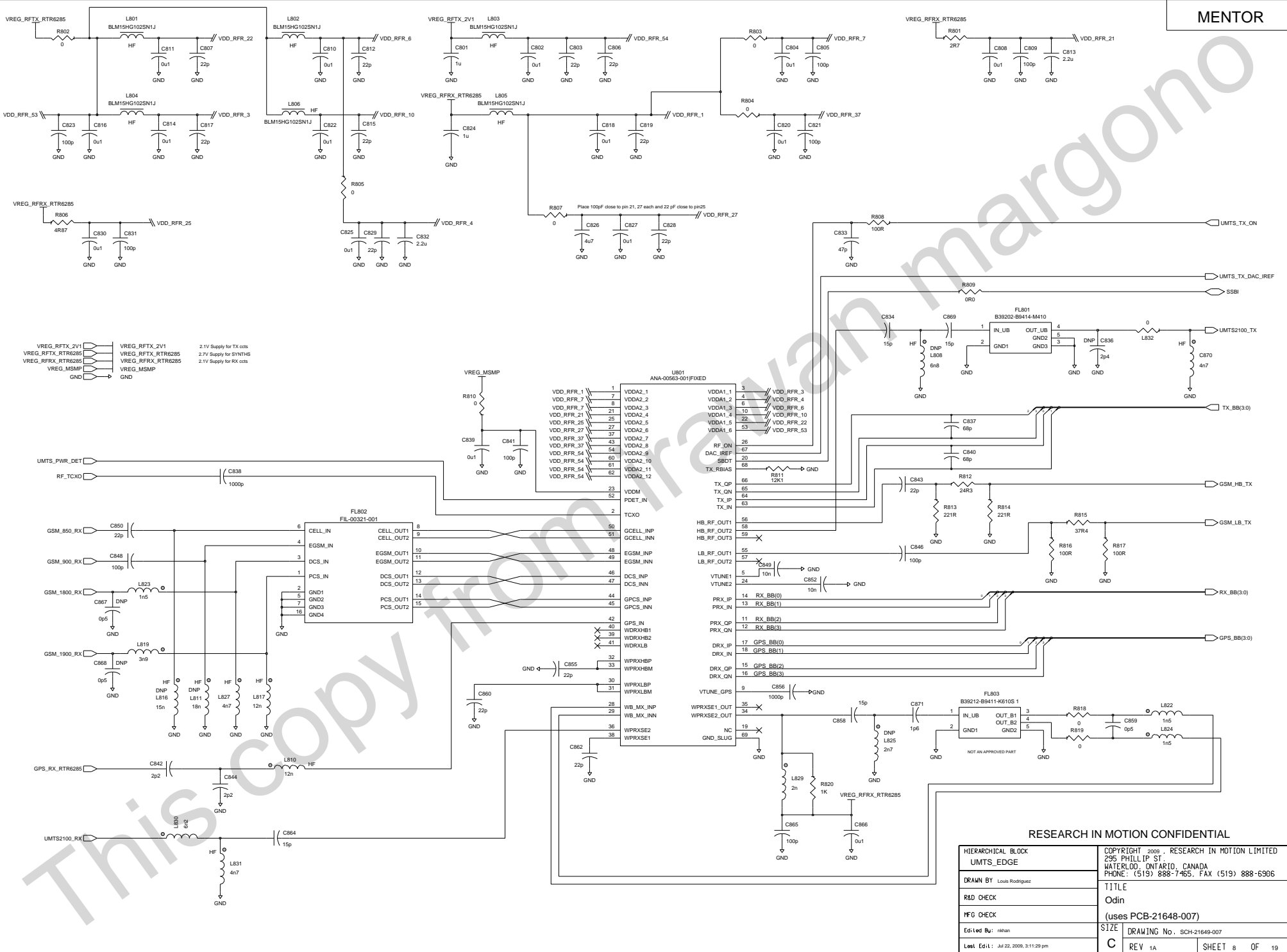

RESEARCH IN MOTION CONFIDENTIAL

HIERARCHICAL BLOCK	UMTS_EDGE	COPYRIGHT 2009, RESEARCH IN MOTION LIMITED
DRAWN BY	Louis Rodriguez	295 PHILLIP ST.
R&D CHECK		WATERLOO, ONTARIO, CANADA
IFG CHECK		PHONE: (519) 888-7465, FAX (519) 888-6306
Edi Led Bu:	rkhan	TITLE
Level	Edi 1: Jul 22, 2009, 3:11:29 pm	Odin
		(uses PCB-21648-007)
		SIZE
		C DRAWING No. SCH-21649-007
		REV 1A SHEET 8 OF 19



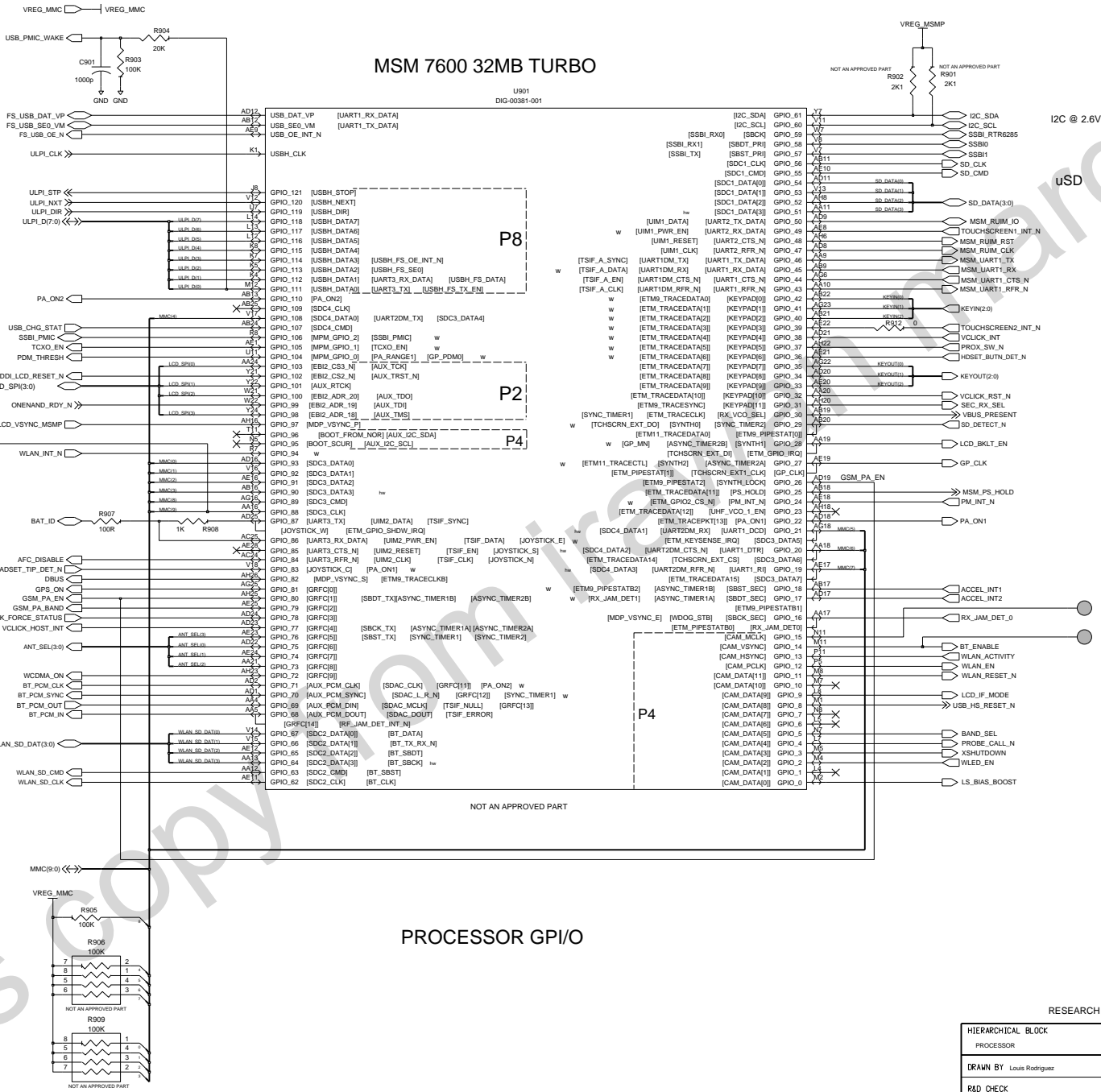

I2C @ 2.6V

uSD

0.5mmsq TP902  
0.5mmsq TP903

RESEARCH IN MOTION CONFIDENTIAL

HIERARCHICAL BLOCK PROCESSOR	COPYRIGHT 2009, RESEARCH IN MOTION LIMITED 295 PHILLIP ST. WATERLOO, ONTARIO, CANADA PHONE: (519) 888-7465, FAX (519) 888-6306
DRAWN BY Louis Rodriguez	TITLE Odin
R&D CHECK	(uses PCB-21648-007)
CFG CHECK	SIZE DRAWING No. SCH-21648-007
Edi Led Bu: Irodrgu	C REV 1A SHEET 9 OF 19
Level: Ed1   Jun 30, 2009, 12:07:00 pm	

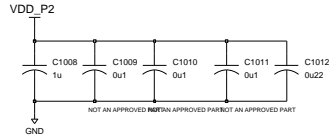
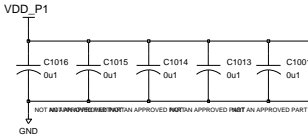
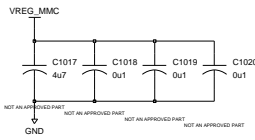

### 7600 MSM 32MB TURBO

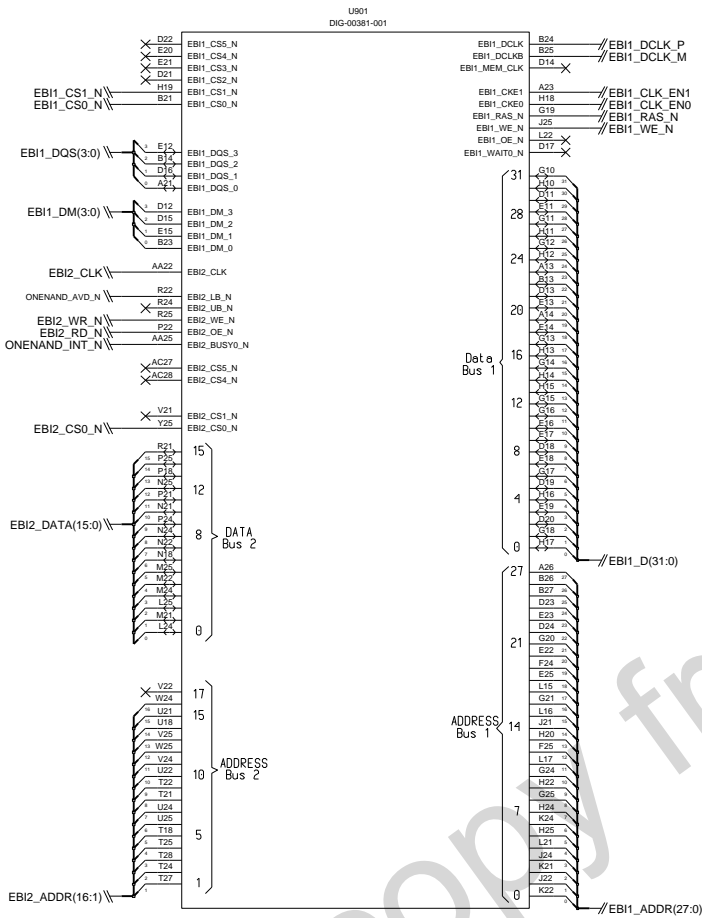

NOT AN APPROVED PART

### 256MB/256MB/2GB

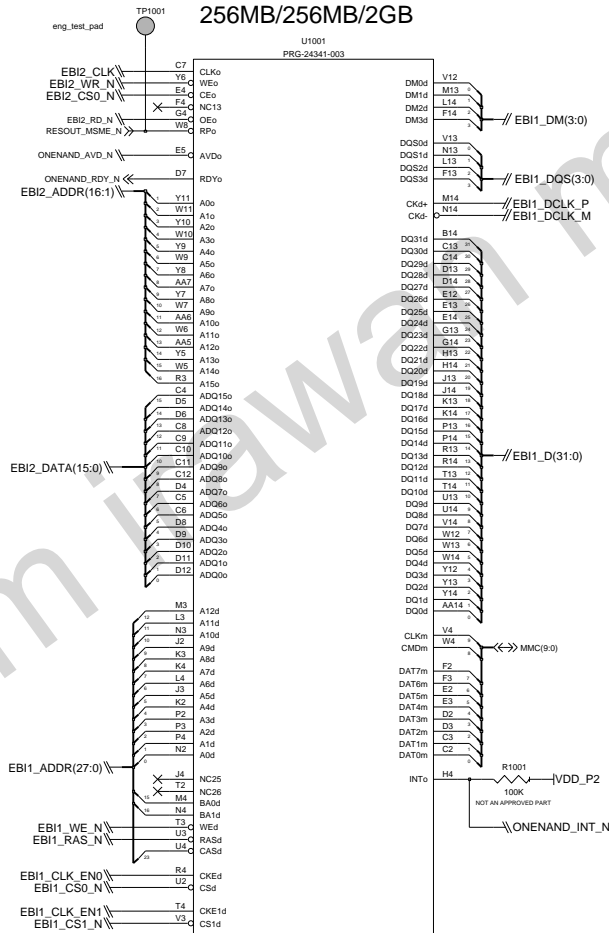

NOT AN APPROVED PART

### 256MB/256MB/2GB

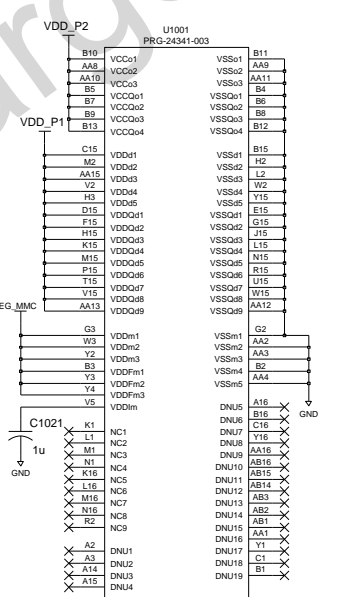

NOT AN APPROVED PART

## PROCESSOR / MEMORY INTERFACE

RESEARCH IN MOTION CONFIDENTIAL

HIERARCHICAL BLOCK PROCESSOR2		COPYRIGHT 2009, RESEARCH IN MOTION LIMITED 295 PHILLIP ST. WATERLOO, ONTARIO, CANADA PHONE: (519) 888-7465, FAX (519) 888-6306	
DRAWN BY: Louis Rodriguez		TITLE Odin	
R&D CHECK		(uses PCB-21648-007)	
MFG CHECK		SIZE DRAWING No. SCH-21649-007	
Edi Led Bu: Irodriugu		C	
Last Edi: Jun 18, 2009, 3:28:34 pm		REV 1A SHEET 10 OF 19	

MSM 7600 32MB TURBO

U001  
DIG-03081-001

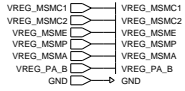

4

3

2

1

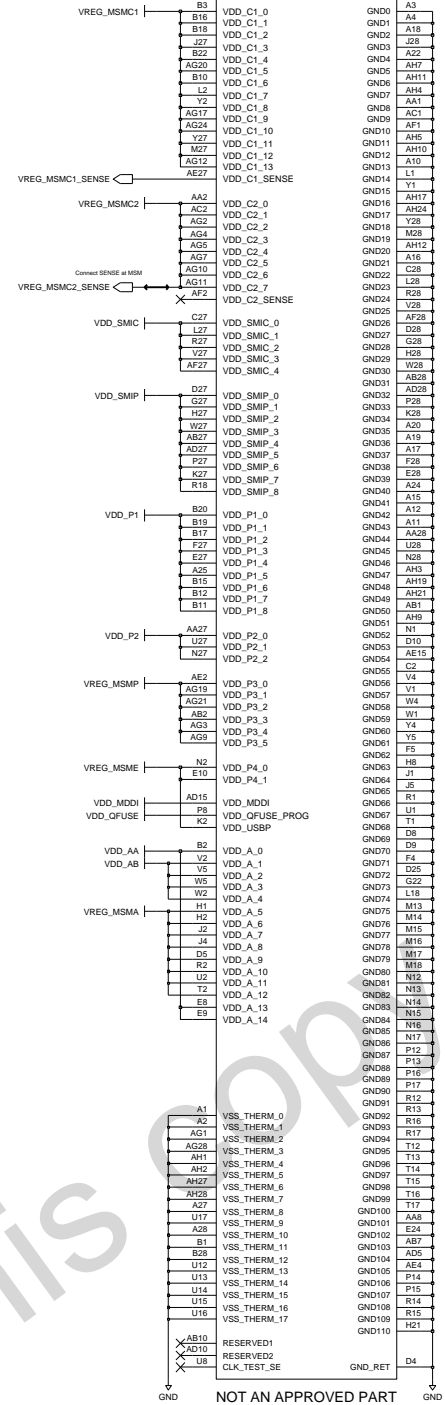

CAD Note: Please VSSN\_MSMC at the branch of MSM and DDR  
CAD Note: All VREG\_MSMA related decoupling caps should attach to inner GND plane and NOT to 1st layer Digital GND floor.  
P1 is Camera interface, could be MSME or MSMP  
P2 is HSUSB interface, could be MSME or MSMP

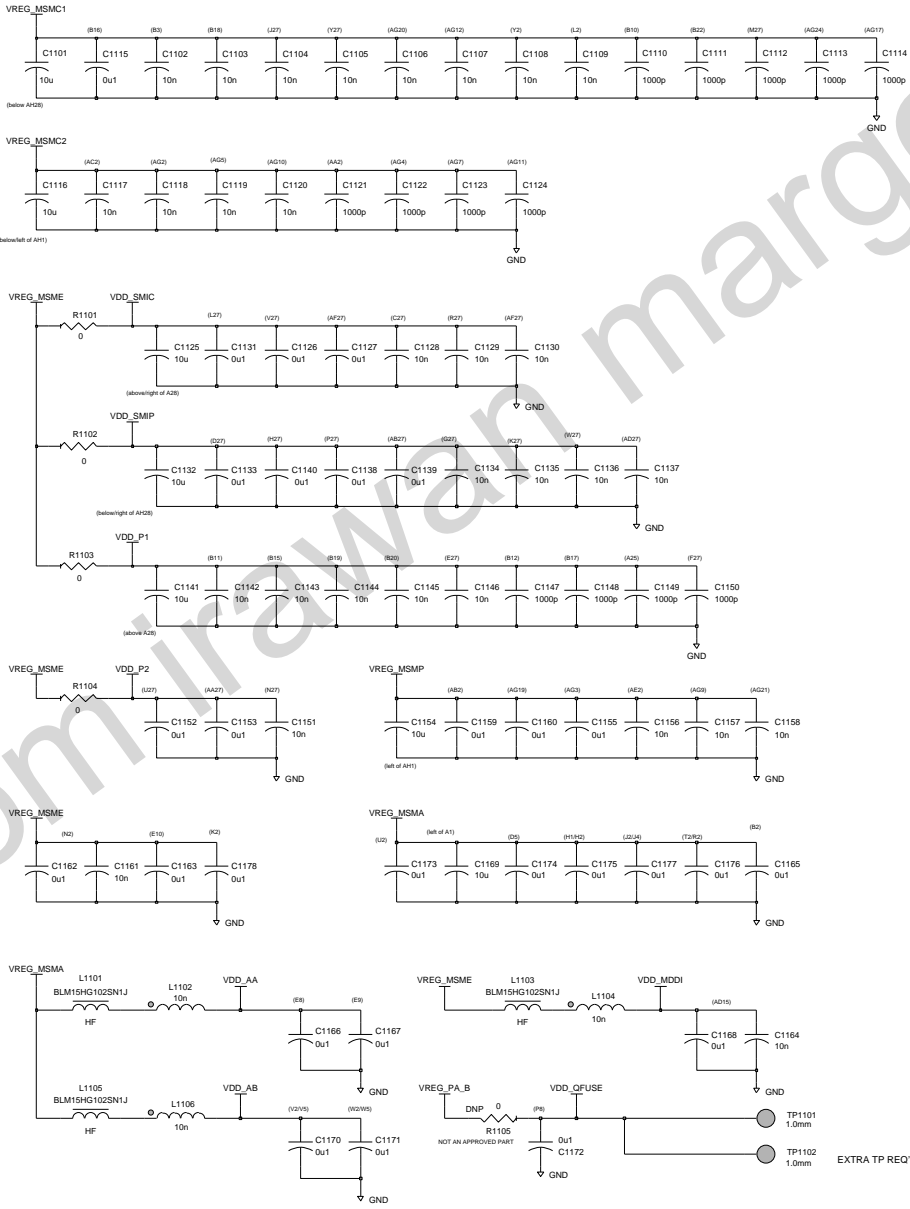

PROCESSOR PWR / GND

RESEARCH IN MOTION CONFIDENTIAL

HIERARCHICAL BLOCK PROCESSOR3		COPYRIGHT 2009, RESEARCH IN MOTION LIMITED 295 PHILLIP ST. WATERLOO, ONTARIO, CANADA PHONE: (519) 888-7465, FAX (519) 888-6306	
DRAWN BY Louis Rodriguez		TITLE Odin	
R&D CHECK		(uses PCB-21648-007)	
MFG CHECK		SIZE DRAWING No. SCH-21649-007	
Edi Led By: Irodrgnu		c	
Last Edt: Jul 1, 2009, 6:24:47 pm		REV 1A	SHEET 11 OF 19

4

3

2

1

Note: vias for TP1205 - TP1210 were removed for security

### MSM 7600 32MB TURBO

U901  
DIG-00381-001

1.2mm req for pogo

JTAG (11x)

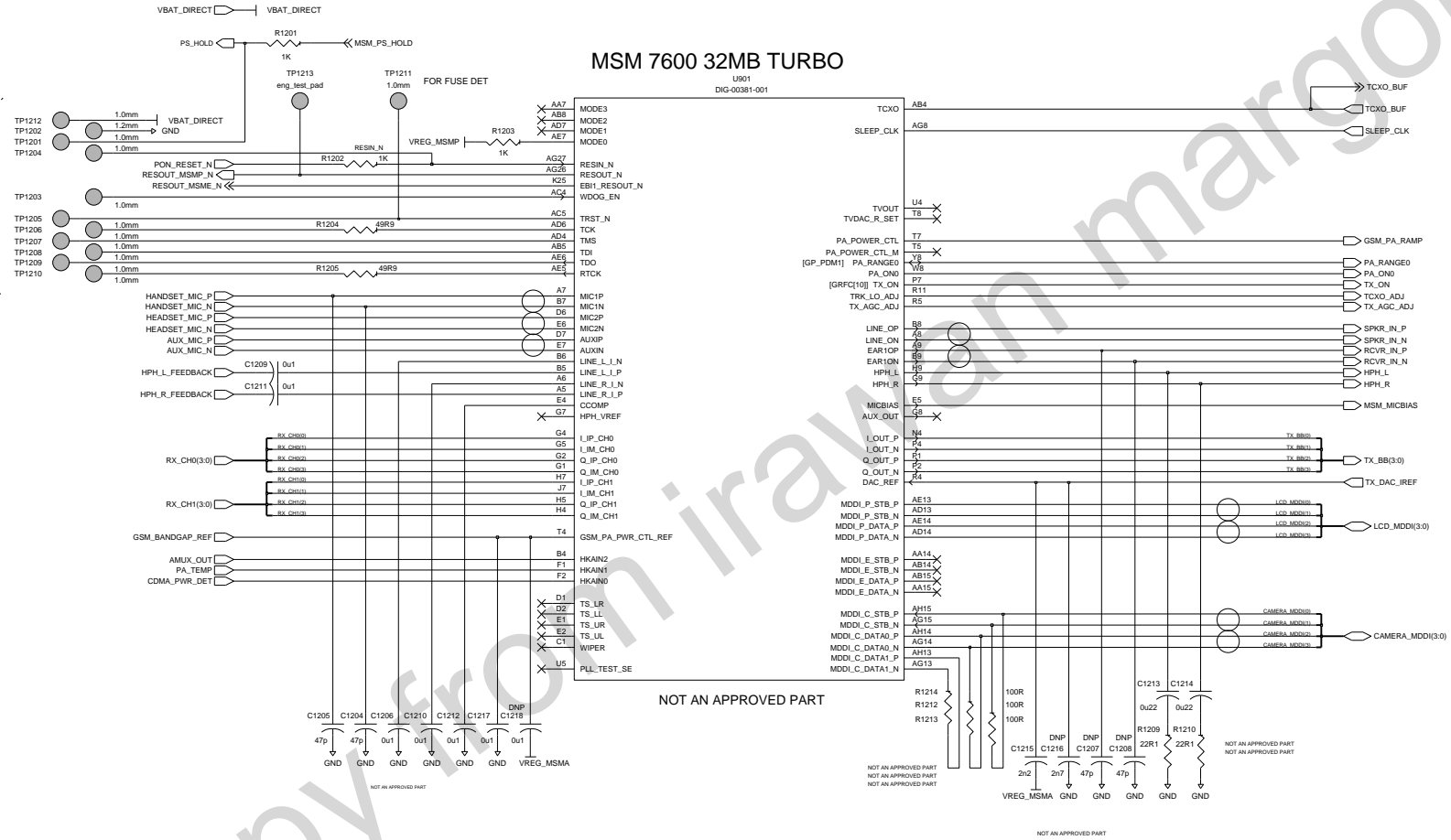

NOT AN APPROVED PART

### PROCESSOR AUDIO / IMAGE PROCESSING

RESEARCH IN MOTION CONFIDENTIAL

HIERARCHICAL BLOCK PROCESSOR4		COPYRIGHT 2009, RESEARCH IN MOTION LIMITED 295 PHILLIP ST. WATERLOO, ONTARIO, CANADA PHONE: (519) 888-7465, FAX (519) 888-6306	
DRAWN BY: Louis Rodriguez		TITLE Odin	
R&D CHECK		(uses PCB-21648-007)	
MFG CHECK		SIZE DRAWING No. SCH-21649-007	
Ed: Led Bu: Irodigu		C	
Level: Ed:1: Aug 6, 2009, 7:01:29 pm		REV 1A SHEET 12 OF 19	

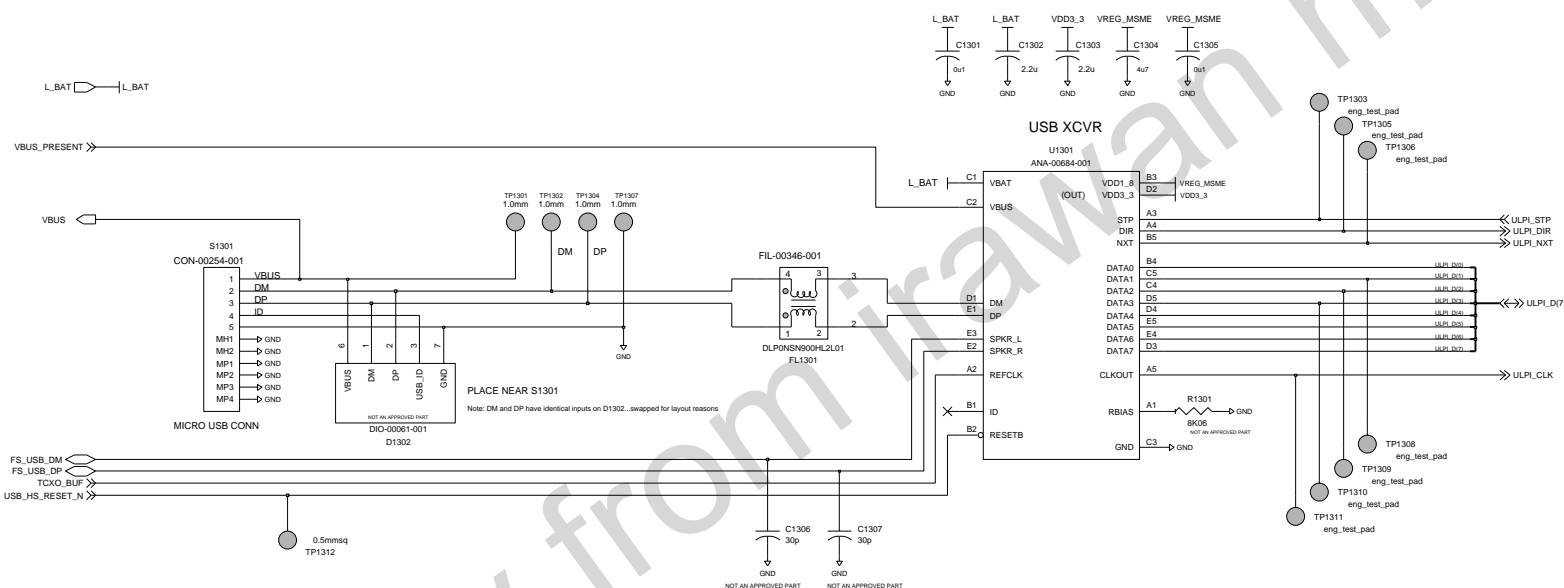

RESEARCH IN MOTION CONFIDENTIAL

HIERARCHICAL BLOCK PROCESSORS		COPYRIGHT 2009, RESEARCH IN MOTION LIMITED 295 PHILLIP ST. WATERLOO, ONTARIO, CANADA PHONE: (519) 888-7465, FAX (519) 888-6306	
DRAWN BY: Louis Rodriguez		TITLE Odin	
R&D CHECK		(uses PCB-21648-007)	
MFG CHECK		SIZE DRAWING No. SCH-21649-007	
Ed: Led Bu: Irodigu		C	
Last Ed: 1: Aug 21, 2009, 12:16:34 pm		REV 1A	SHEET 13 OF 19

This copy from irawan margono

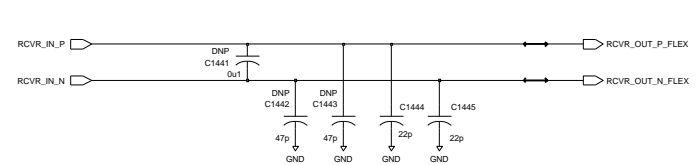
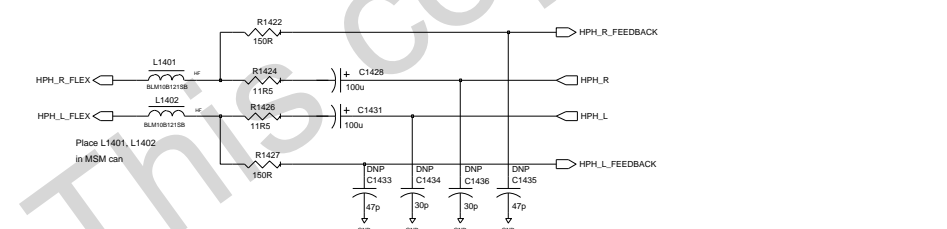
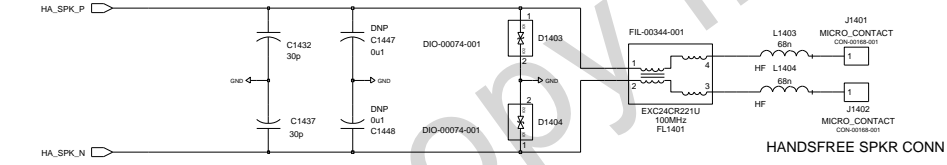
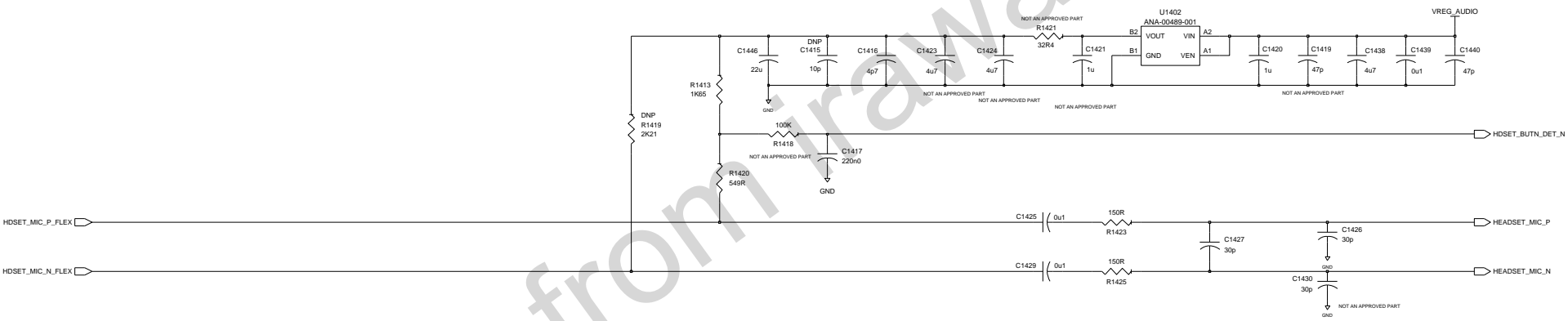
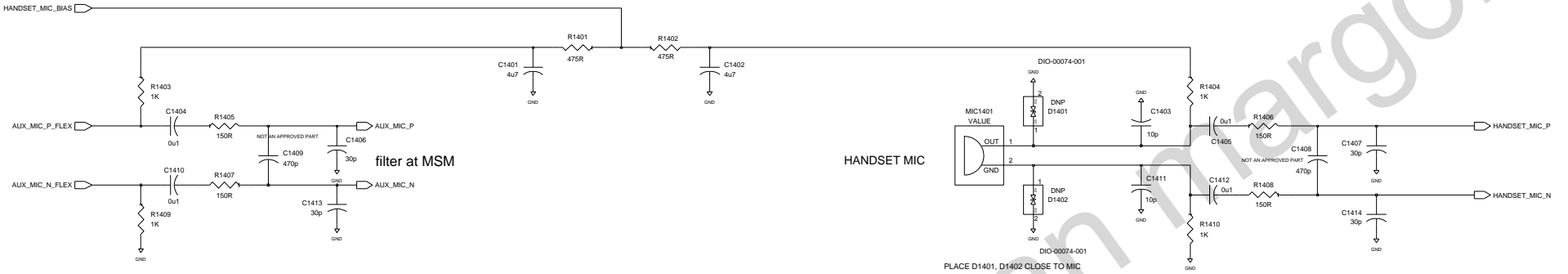
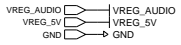

RESEARCH IN MOTION CONFIDENTIAL

HIERARCHICAL BLOCK AUDIO		COPYRIGHT 2009, RESEARCH IN MOTION LIMITED 295 PHILLIP ST. WATERLOO, ONTARIO, CANADA PHONE: (519) 888-7465, FAX (519) 888-6306	
DRAWN BY Louis Rodriguez		TITLE Odin	
R&D CHECK		(uses PCB-21648-007)	
MFG CHECK		SIZE DRAWING No. SCH-21649-007	
Ed: Led Bu: Irodigu		C	
Level Ed:1: Jun 18, 2009, 3:11:19 pm		REV 1A	SHEET 14 OF 19

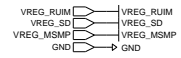

### SIM CONN

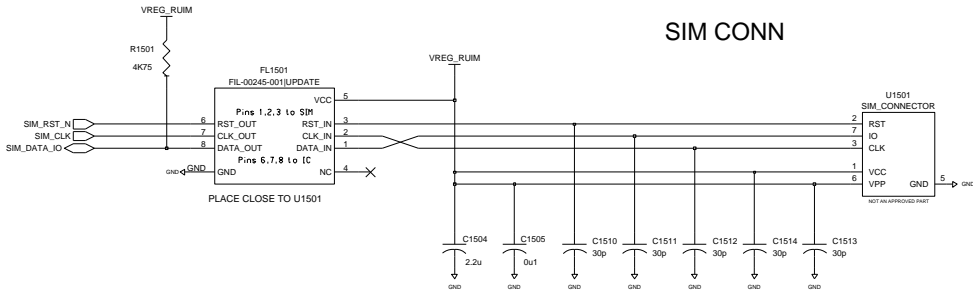

### PROXIMITY SWITCH

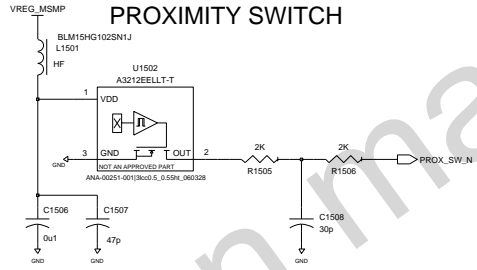

### USD CONN

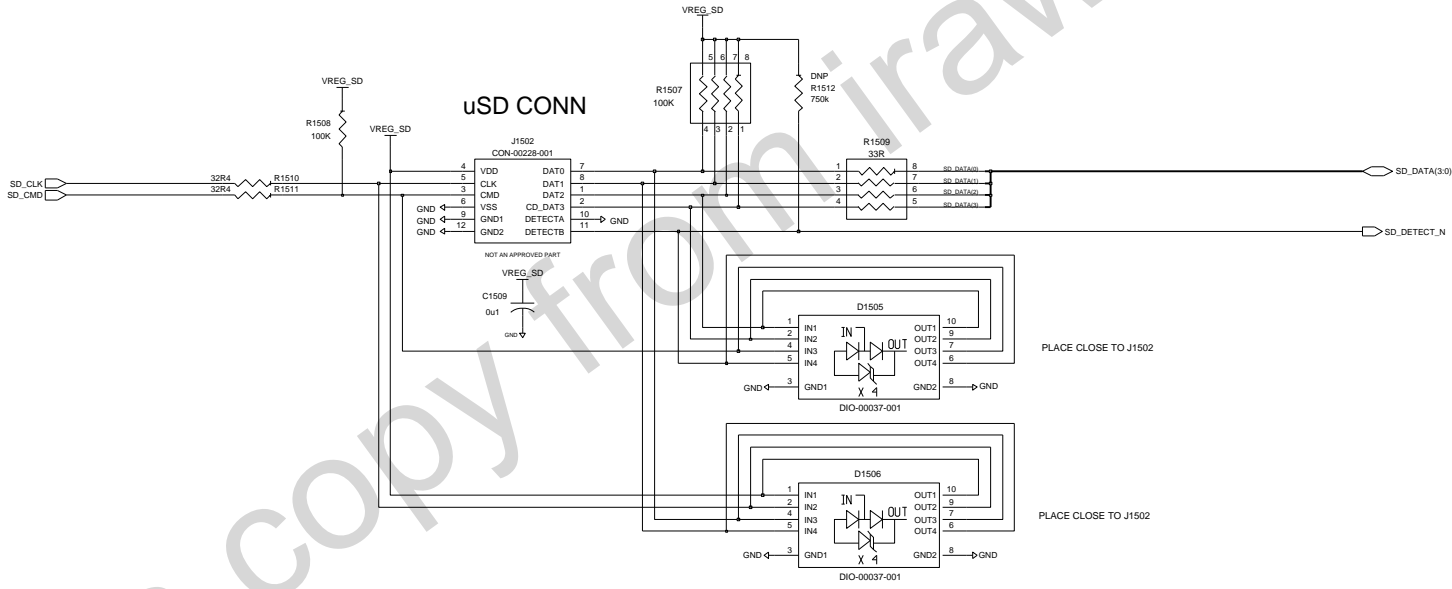

RESEARCH IN MOTION CONFIDENTIAL

HIERARCHICAL BLOCK SIM_USD	COPYRIGHT 2009, RESEARCH IN MOTION LIMITED 295 PHILLIP ST. WATERLOO, ONTARIO, CANADA PHONE: (519) 888-7465, FAX (519) 888-6306
DRAWN BY Louis Rodriguez	TITLE Odin
R&D CHECK	(uses PCB-21648-007)
MFG CHECK	SIZE DRAWING No. SCH-21649-007
Edi Led Bu: Irodigu	C REV 1A SHEET 15 OF 19
Level Edi L: Jun 18, 2009, 3:18:31 pm	

D

D

C

C

B

B

A

A

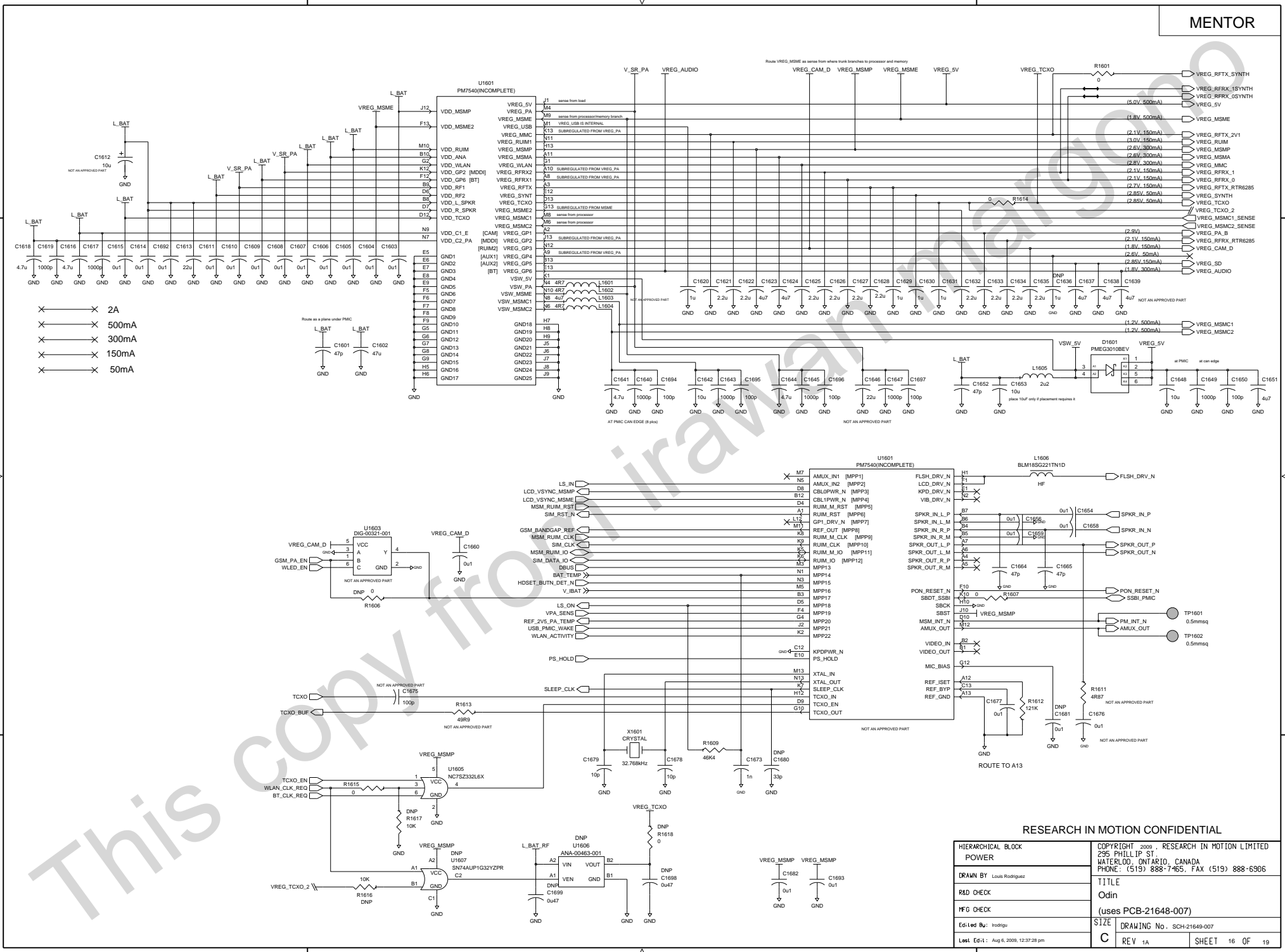

RESEARCH IN MOTION CONFIDENTIAL

HIERARCHICAL BLOCK POWER		COPYRIGHT 2009, RESEARCH IN MOTION LIMITED 295 PHILLIP ST. WATERLOO, ONTARIO, CANADA PHONE: (519) 888-7465, FAX (519) 888-6306	
DRAWN BY	Louis Rodriguez	TITLE	Odin
R&D CHECK			(uses PCB-21648-007)
MFG CHECK		SIZE	DRAWING No. SCH-21649-007
Edi Led Bu:	lrodru	C	REV 1A SHEET 16 OF 19
Label	Edi 1: Aug 6, 2009, 12:37:28 pm		



VBUS

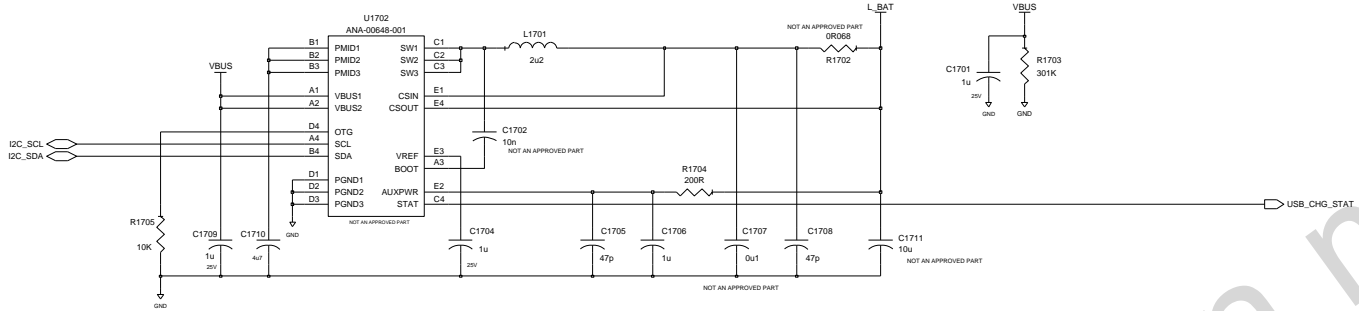

BATT CONN

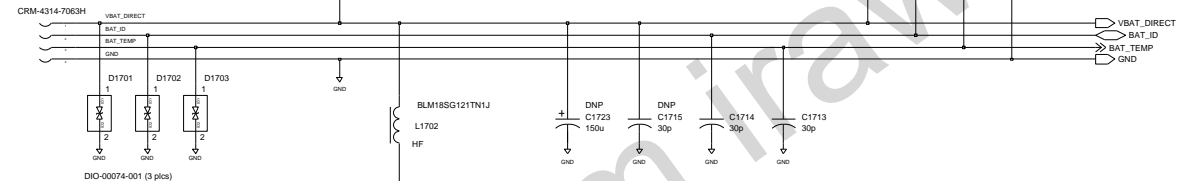

PLACE DIODES NEAR CONN

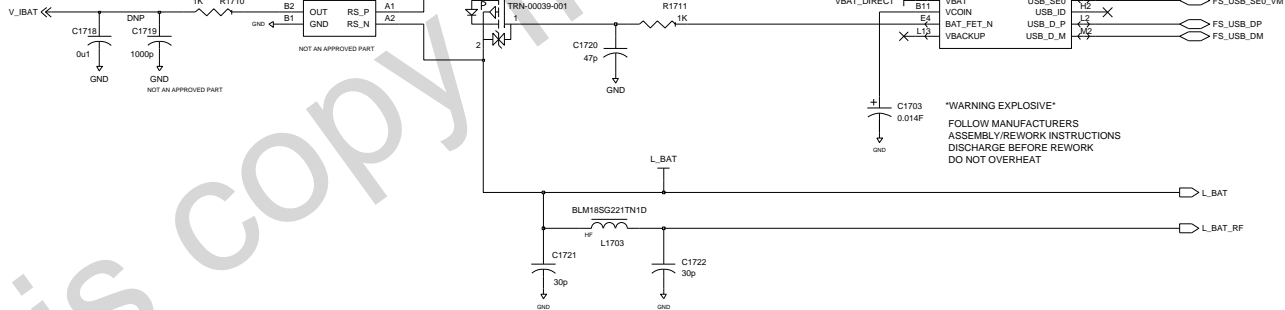

**\*WARNING EXPLOSIVE\***  
 FOLLOW MANUFACTURERS  
 ASSEMBLY/REWORK INSTRUCTIONS  
 DISCHARGE BEFORE REWORK  
 DO NOT OVERHEAT

RESEARCH IN MOTION CONFIDENTIAL

HIERARCHICAL BLOCK POWER2		COPYRIGHT 2009, RESEARCH IN MOTION LIMITED 295 PHILLIP ST. WATERLOO, ONTARIO, CANADA PHONE: (519) 888-7465, FAX (519) 888-6306	
DRAWN BY: Louis Rodriguez		TITLE Odin	
R&D CHECK		(uses PCB-21648-007)	
MFG CHECK		SIZE DRAWING No. SCH-21649-007	
Edi Led Bu: rnkhan		C REV 1A SHEET 17 OF 19	
Last Ed: 1 Jul 22, 2009, 3:17:07 pm			

2A

FLEX CONN

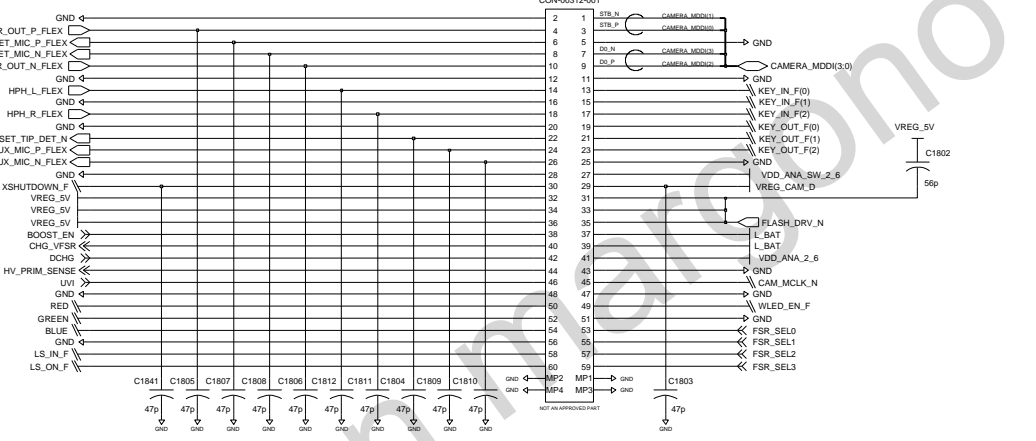

LCD CONN

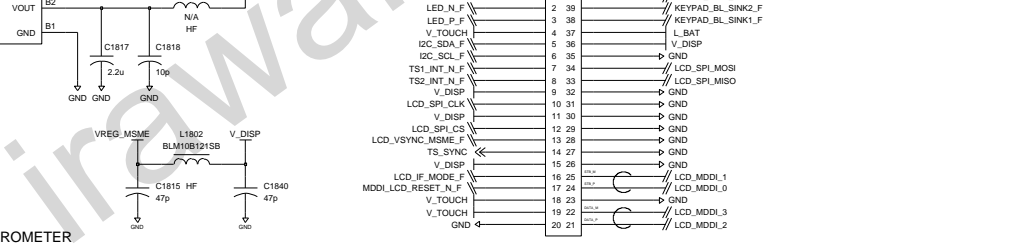

ACCELEROMETER

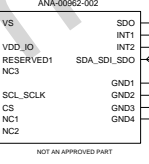

LCD CONN

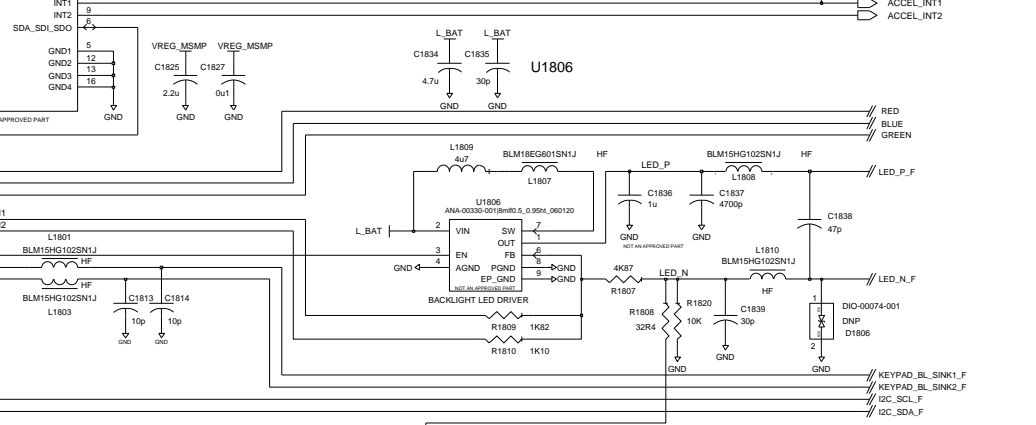

RESEARCH IN MOTION CONFIDENTIAL

HIERARCHICAL BLOCK JOINTERFACE		COPYRIGHT 2000, RESEARCH IN MOTION LIMITED 295 PHILLIP ST. WATERLOO, ONTARIO, CANADA PHONE: (519) 888-7465, FAX (519) 888-6306	
DRAWN BY: Luis Rodriguez		TITLE Odin (uses PCB-21648-007)	
R&D CHECK		SIZE DRAWING No. BCH-21648-007	
MFG CHECK		C REV 1A SHEET 18 OF 19	
Edi Led Bu: poorbatt		Lobl Ed1: Aug 25, 2009, 9:25:02 am	

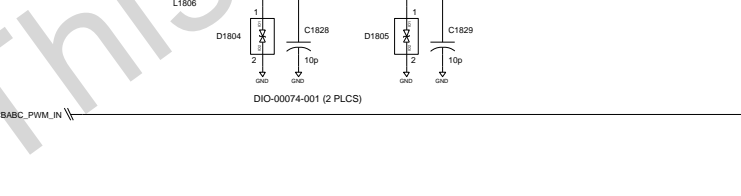
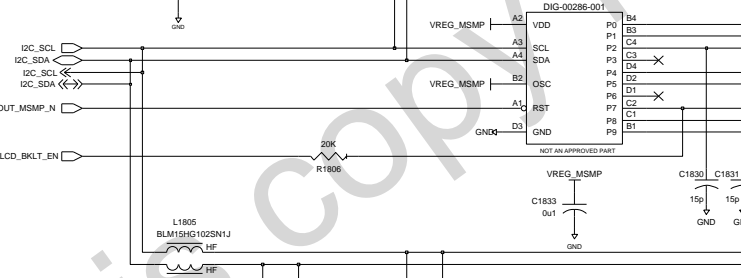
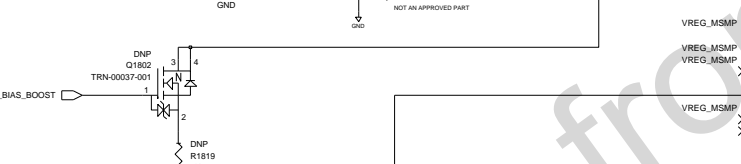
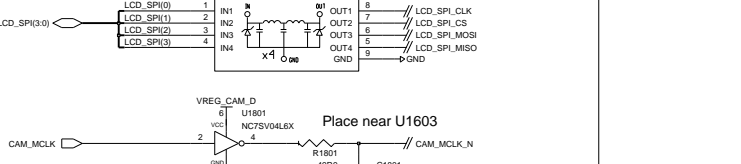
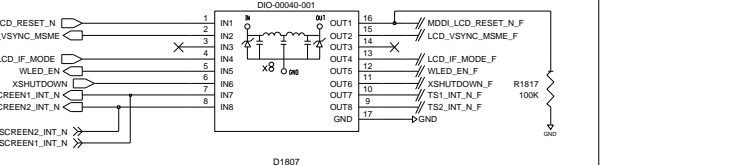
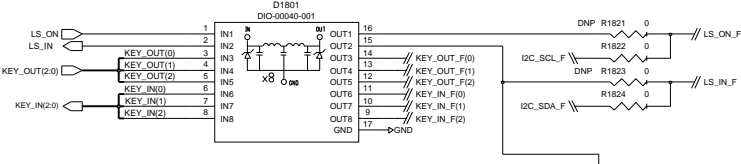
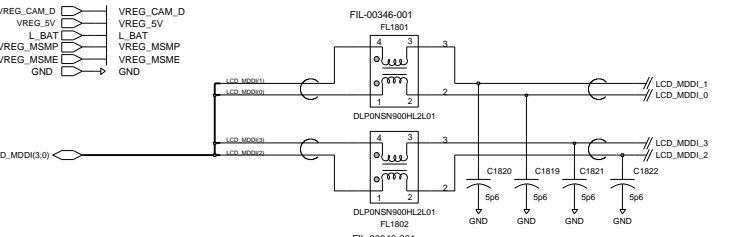

Note: vias for TP1904-TP1901 have been removed for security

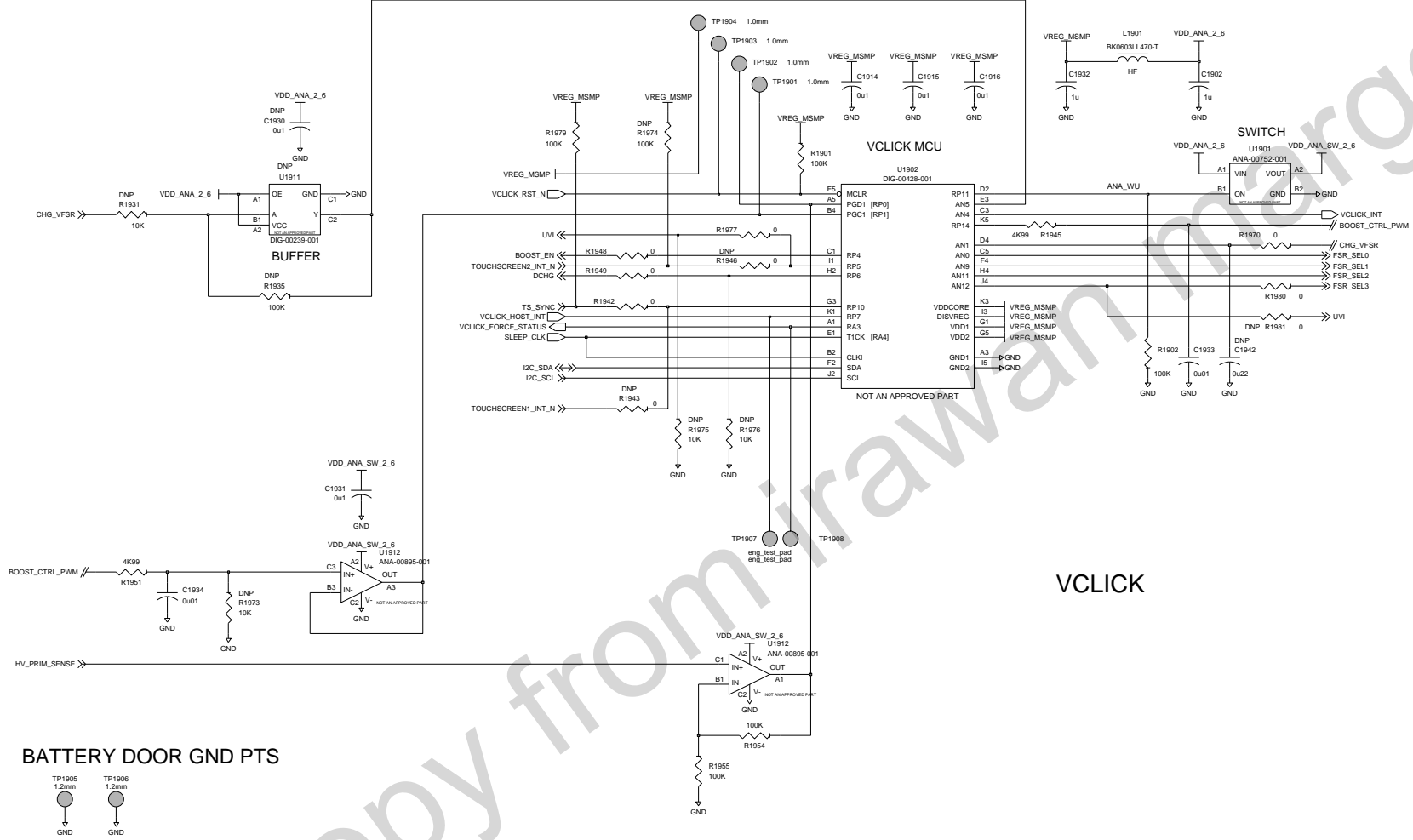

BATTERY DOOR GND PTS

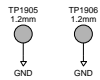

PCB PANEL PERFORATIONS

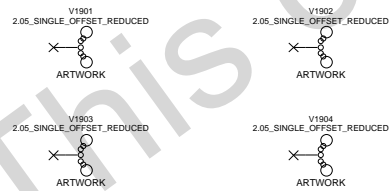

SHIELD CANS

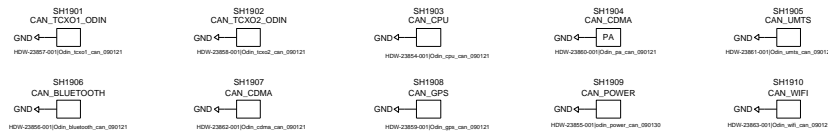

RESEARCH IN MOTION CONFIDENTIAL

HIERARCHICAL BLOCK JOINTERFACE2		COPYRIGHT 2009, RESEARCH IN MOTION LIMITED 295 PHILLIP ST. WATERLOO, ONTARIO, CANADA PHONE: (519) 888-7465, FAX (519) 888-6306	
DRAWN BY: Louis Rodriguez		TITLE Odin (uses PCB-21648-007)	
R&D CHECK		SIZE DRAWING No. SCH-21649-007	
MFG CHECK		C REV 1A SHEET 19 OF 19	
Edi Led Bu: poorbelt		Level Ed1: Jul 24, 2009, 10:22:51 am	