

Sheet	Ref.
TOP	
RF_ANT	2XX
AFE_TX	3XX
WB_AFE	4XX
WB_AFE2	5XX
A=GPS	6XX
AUDIO	7XX
IO_INTERF	8XX
POWER	9XX
POWER2	10XX
SIM/PROX	11XX
BT_WLAN	12XX
TAVOR_GPIO	13XX
TAVOR_MEM	14XX
TAVOR_SERV	15XX
IO_INTERF2	16XX
TAVOR_POW	17XX
KEYPAD 1	18XX
KEYPAD 2	19XX

RESEARCH IN MOTION CONFIDENTIAL

HIERARCHICAL BLOCK

COPYRIGHT 2010 RESEARCH IN MOTION LIMITED
295 PHILLIP ST.
WATERLOO, ONTARIO CANADA

PHONE (519) 888-7465 FAX (519) 888-6986

TITLE
R011 Main PCB Schematic

Uses PCB-29964-009

DRAWN BY: Flor1da PDC

RWD CHECK: Flor1da PDC

MFG CHECK: UNKNOWN

EDITED BY: ma7loris

LAST EDIT: 2010/11/25 09:56:45

SIZE: C

DRAWING No. SCH-29965-009

REV 6 SHEET 1 of 19

RF_ANT

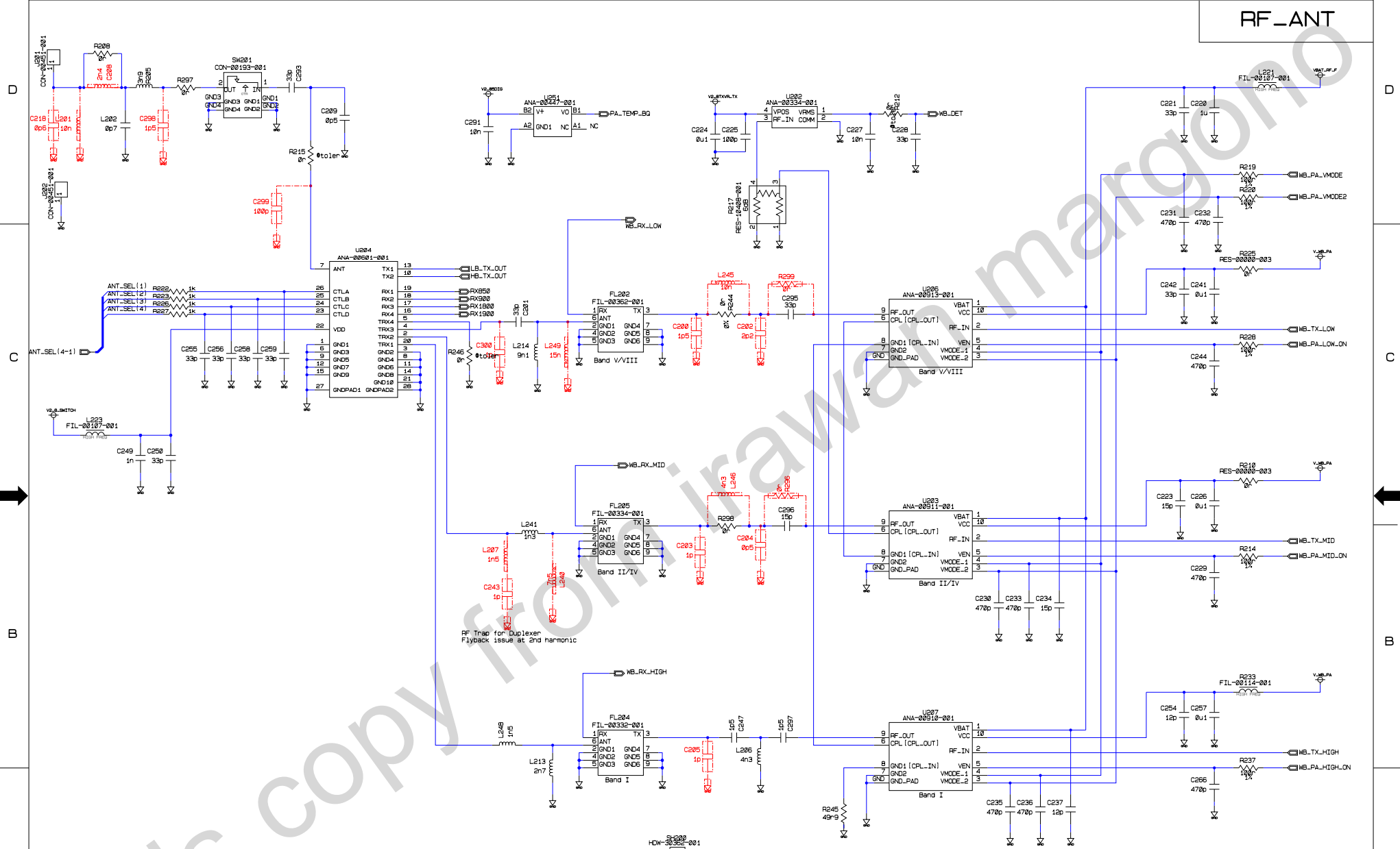

This copy is for internal use only. All rights reserved.

RESEARCH IN MOTION CONFIDENTIAL	
HIERARCHICAL BLOCK	COPYRIGHT 2010 RESEARCH IN MOTION LIMITED 295 PHILIP ST. WATERLOO, ONTARIO CANADA
DRAWN BY	PHONE (519) 888-7465, FAX (519) 888-6806
RWD CHECK	TITLE
MFG CHECK	R011 Main PCB Schematic
EDITED BY:	Uses PCB-29964-009
LAST EDIT:	SIZE
2010/11/25 09:59:13	DRAWING No. SCH-29965-009
	REV 6 SHEET 2 of 19

AFE_TX

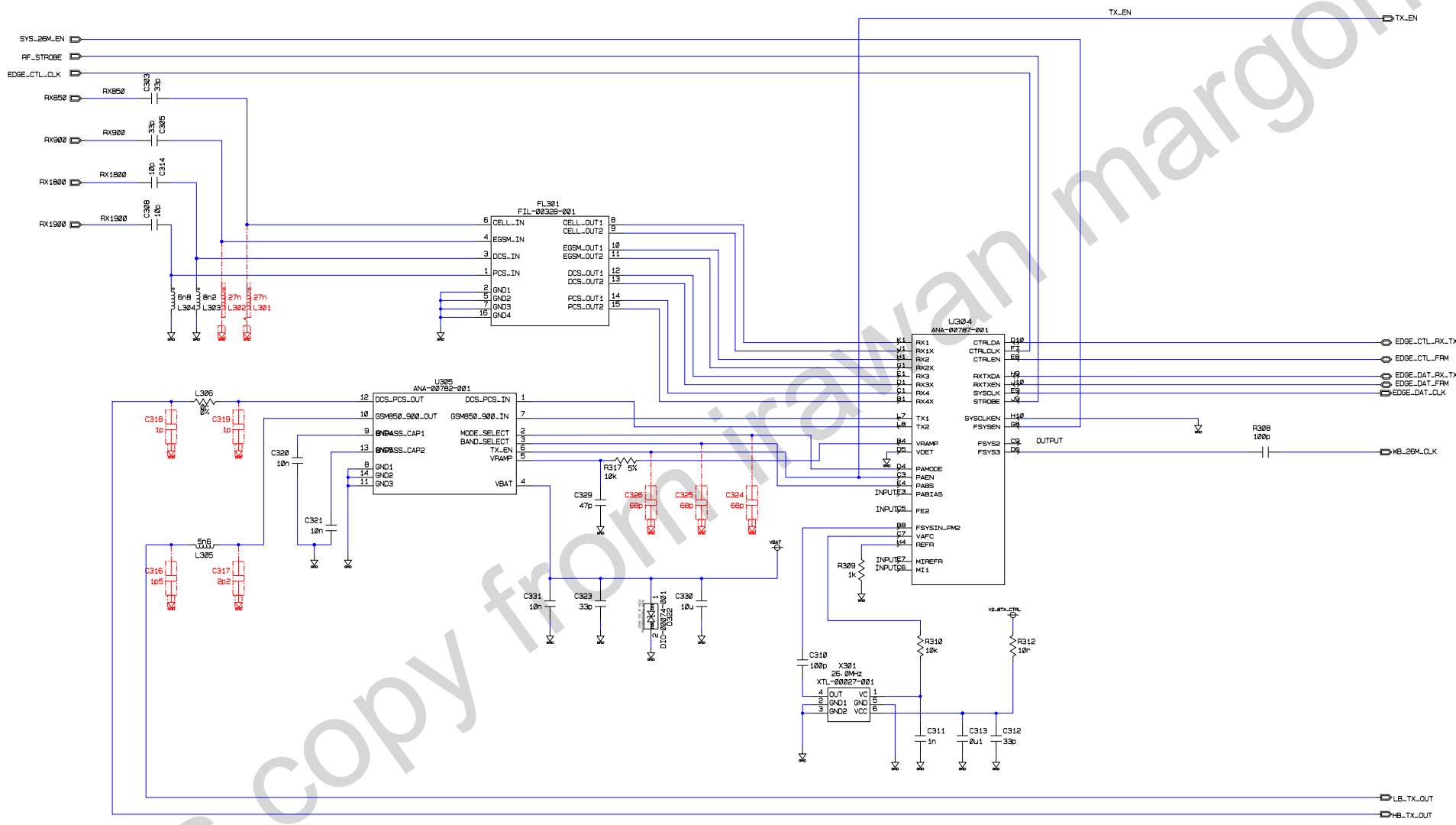

RESEARCH IN MOTION CONFIDENTIAL

HIERARCHICAL BLOCK	COPYRIGHT 2010 RESEARCH IN MOTION LIMITED 295 PHILIP ST. WATERLOO, ONTARIO CANADA
DRAWN BY Florida RDC	PHONE (519) 888-7465 FAX (519) 888-6906
RAD CHECK Florida RDC	TITLE R011 Main PCB Schematic
MFG CHECK UNKNOWN	Uses PCB-29964-009
EDITED BY: maffores	SIZE DRAWING No. SCH-29965-009
LAST EDIT: 2010/11/25 16:42:56	REV 6 SHEET 3 of 19

WB_AFE

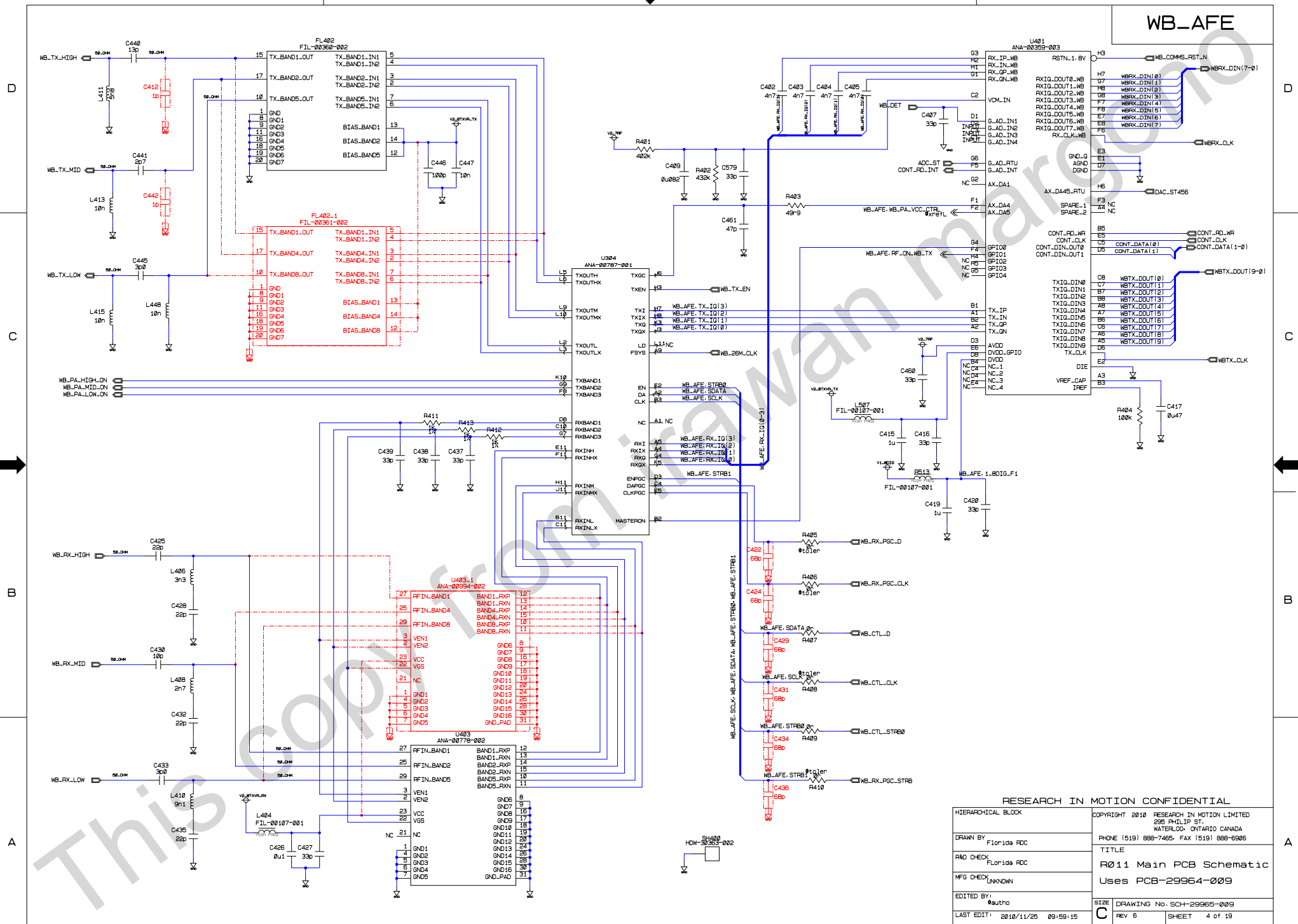

RESEARCH IN MOTION CONFIDENTIAL	
HIERARCHICAL BLOCK	COPYRIGHT 2010 RESEARCH IN MOTION LIMITED 295 PHILIP ST. WATERLOO, ONTARIO CANADA
DRAWN BY F1or1da PDC	PHONE (519) 888-7465, FAX (519) 888-6686
RWD CHECK F1or1da PDC	TITLE R011 Main PCB Schematic
MFG CHECK UNKNOWN	Uses PCB-29964-009
EDITED BY 0autho	SIZE DRAWING No. SCH-29965-009
LAST EDIT: 2010/11/25 09:59:15	REV 6 SHEET 4 of 19

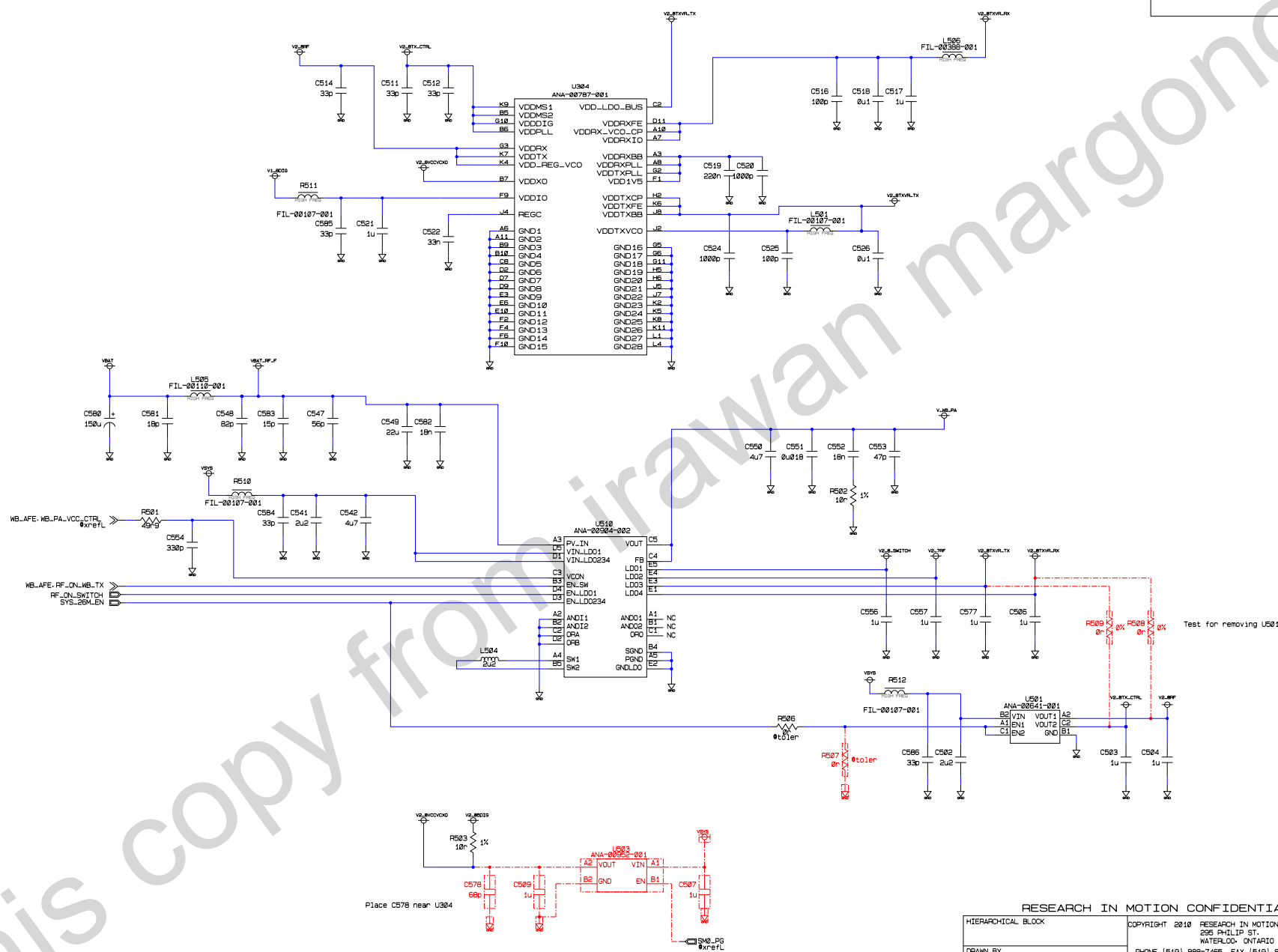

RESEARCH IN MOTION CONFIDENTIAL	
HIERARCHICAL BLOCK	COPYRIGHT 2010 RESEARCH IN MOTION LIMITED 295 PHILLIP ST. WATERLOO, ONTARIO CANADA
DRAWN BY: F1or1da PDC	PHONE (519) 886-7465 FAX (519) 886-6986
RWD CHECK: F1or1da PDC	TITLE: R011 Main PCB Schematic
MFG CHECK: UNKNOWN	Uses PCB-29964-009
EDITED BY: mar1ores	SIZE: DRAWING No. SCH-29965-009
LAST EDIT: 2010/11/25 09:59:16	REV 6 SHEET 5 of 19

A-GPS

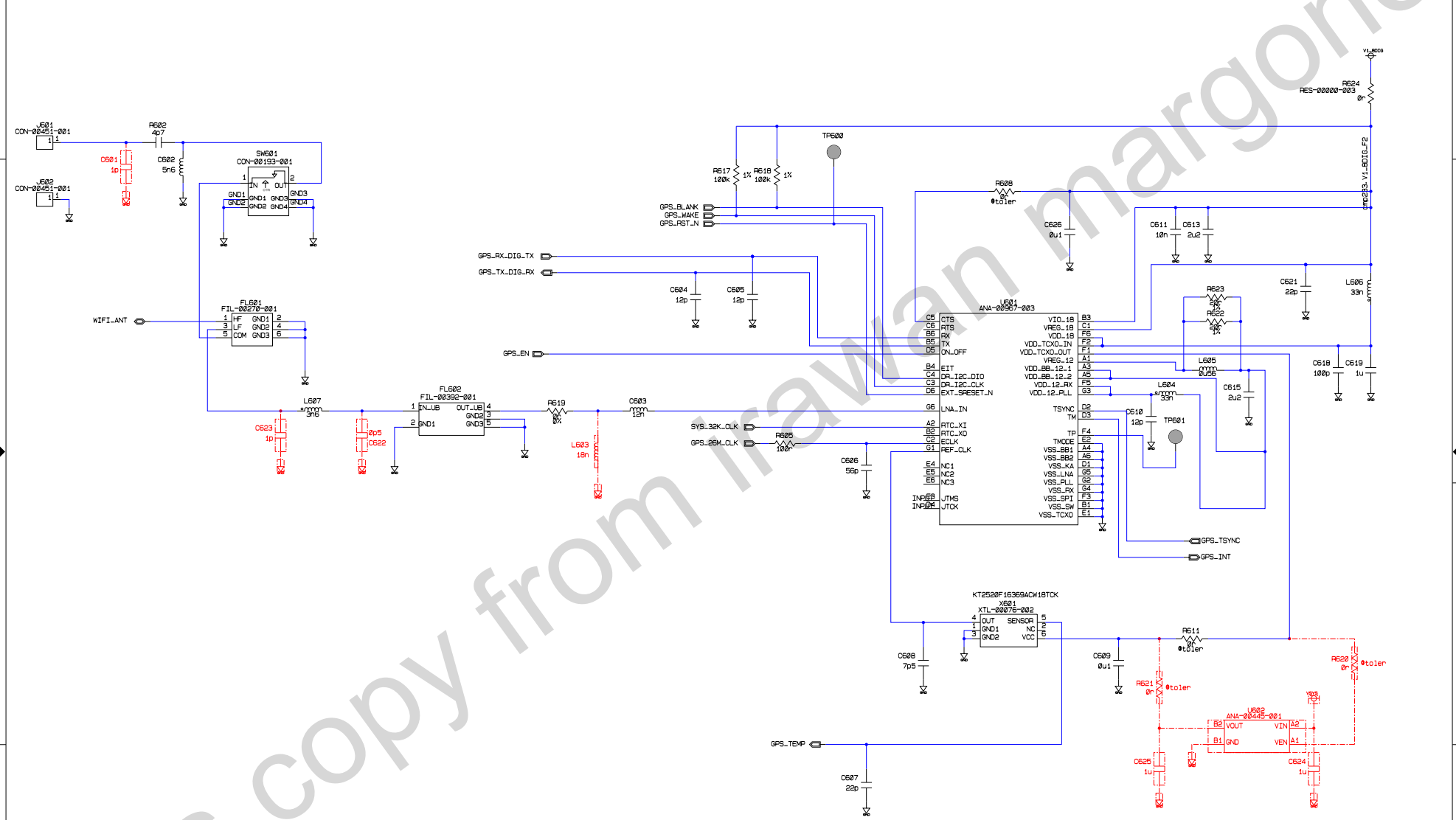

RESEARCH IN MOTION CONFIDENTIAL

HIERARCHICAL BLOCK	COPYRIGHT 2010 RESEARCH IN MOTION LIMITED 295 PHILIP ST. WATERLOO, ONTARIO CANADA PHONE (519) 888-7465, FAX (519) 888-6906
DRAWN BY: FJorlida RDC	TITLE
RWD CHECK: FJorlida RDC	R011 Main PCB Schematic
MFG CHECK: UNKNOWN	Uses PCB-29964-009
EDITED BY: @autho	SIZE
LAST EDIT: 2010/11/25 13:31:48	DRAWING No. SCH-29965-009
	REV 6 SHEET 6 of 19

D

D

C

C

B

B

A

A

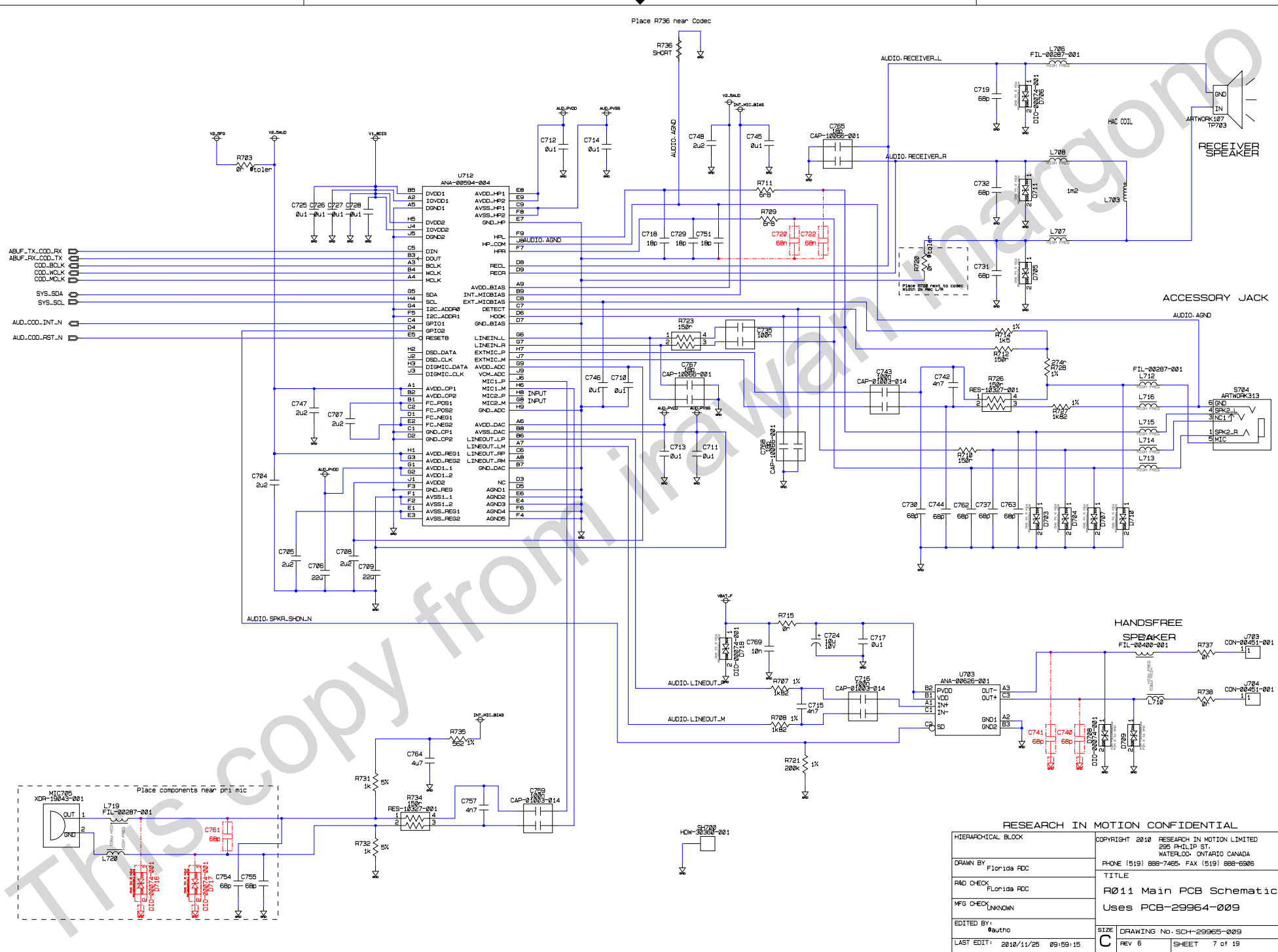

RESEARCH IN MOTION CONFIDENTIAL

HIERARCHICAL BLOCK	COPYRIGHT 2010 RESEARCH IN MOTION LIMITED 295 PHILLIP ST. WATERLOO, ONTARIO CANADA PHONE (519) 888-7465, FAX (519) 888-6986
DRAWN BY F1or1da PDC	TITLE R011 Main PCB Schematic Uses PCB-29964-009
RWD CHECK F1or1da PDC	SIZE DRAWING No. SCH-29965-009
MFG CHECK UNKNOWN	REV 6 SHEET 7 of 19
EDITED BY: @autho	
LAST EDIT: 2010/11/25 09:59:15	

LCD CONNECTOR

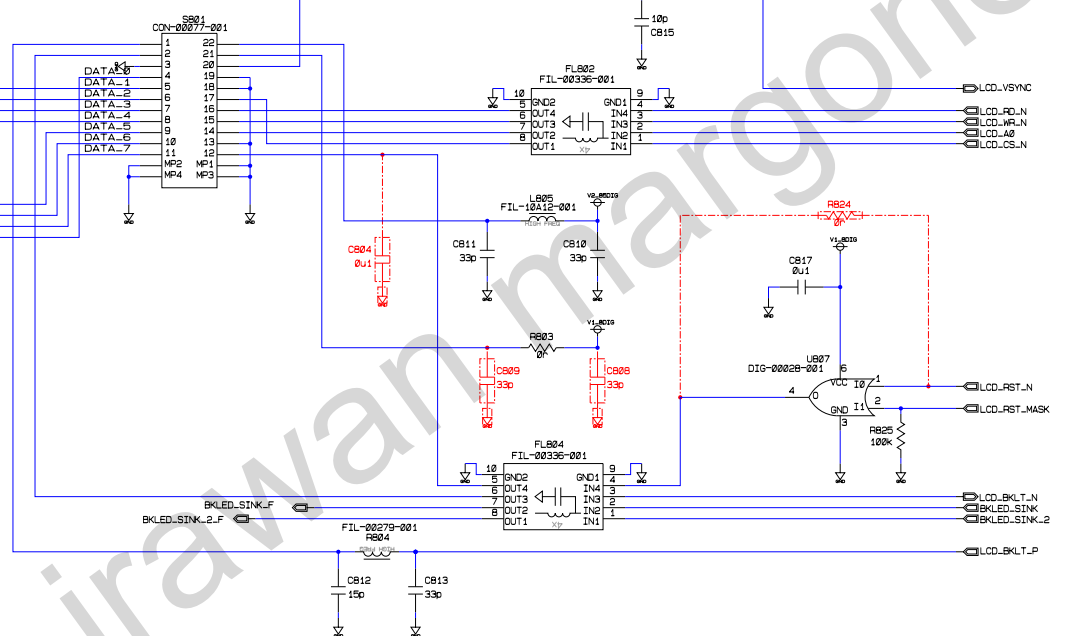

OPTICAL NAVIGATION MODULE CONNECTOR

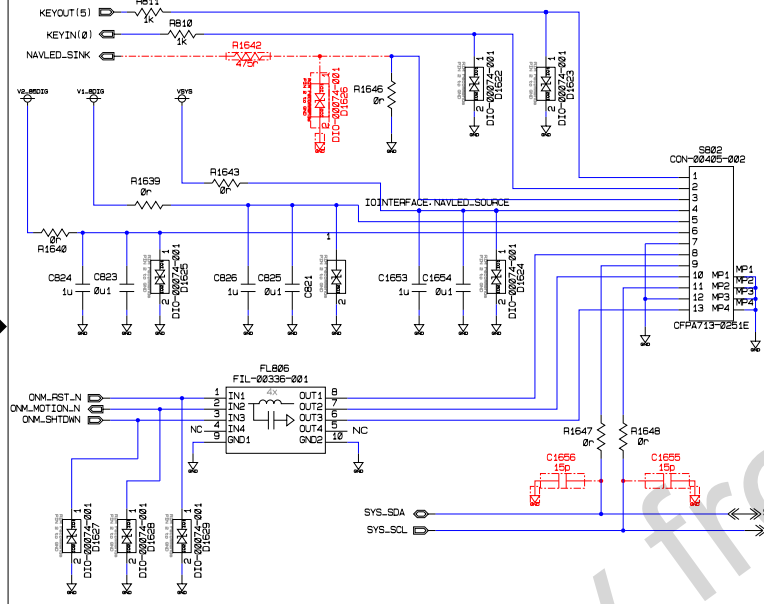

CHARGE/USB CONNECTOR

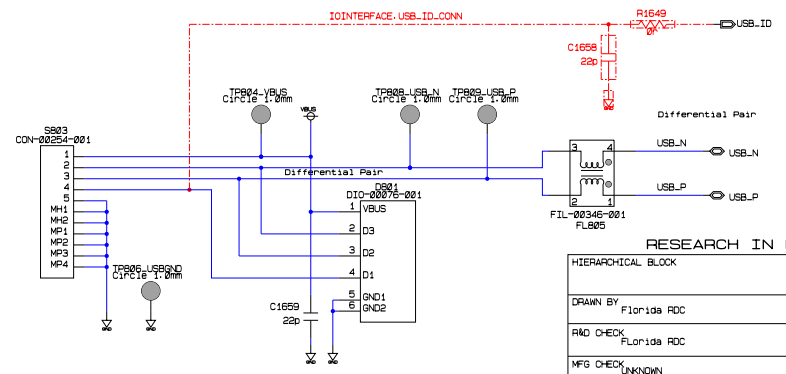

RESEARCH IN MOTION CONFIDENTIAL

HIERARCHICAL BLOCK	COPYRIGHT 2010 RESEARCH IN MOTION LIMITED 295 PHILIP ST. WATERLOO, ONTARIO CANADA
DRAWN BY: F1or1da RDC	PHONE (519) 889-7465 FAX (519) 889-6986
RWD CHECK: F1or1da RDC	TITLE: R011 Main PCB Schematic
MFG CHECK: UNKNOWN	Uses PCB-29964-009
EDITED BY: @autho	SIZE: DRAWING No. SCH-29965-009
LAST EDIT: 2010/11/25 09:59:16	REV 6 SHEET 8 of 19

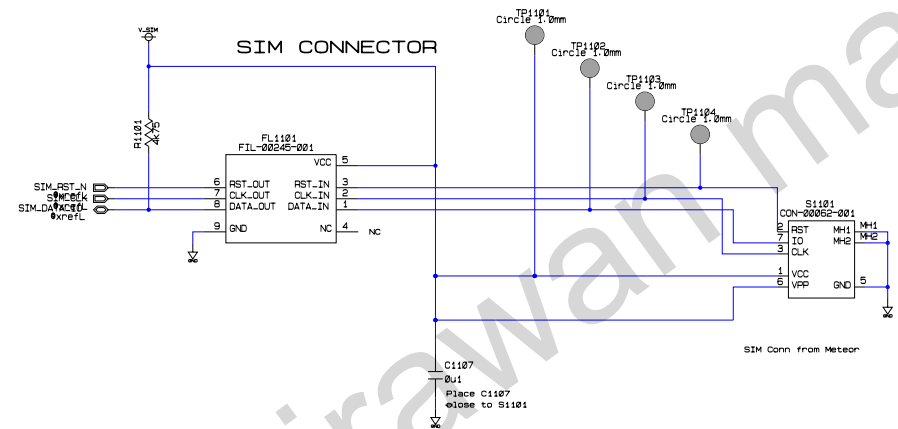

**HOLSTER MAGNET DETECTION
(hall effect proximity sensor)**

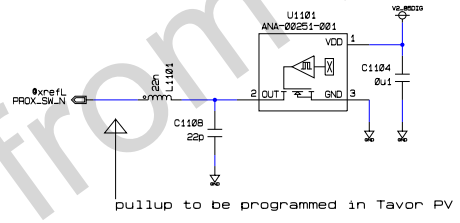

RESEARCH IN MOTION CONFIDENTIAL

HIERARCHICAL BLOCK	COPYRIGHT 2010 RESEARCH IN MOTION LIMITED 295 PHILIP ST. WATERLOO, ONTARIO CANADA
DRAWN BY: F1or1da RDC	PHONE (519) 888-7465 FAX (519) 888-6986
RWD CHECK: F1or1da RDC	TITLE
MFG CHECK: UNKNOWN	R011 Main PCB Schematic Uses PCB-29964-009
EDITED BY: 0autho	SIZE
LAST EDIT: 2010/11/25 09:59:17	DRAWING No. SCH-29965-009
	REV 6 SHEET 11 of 19

BT_WLAN

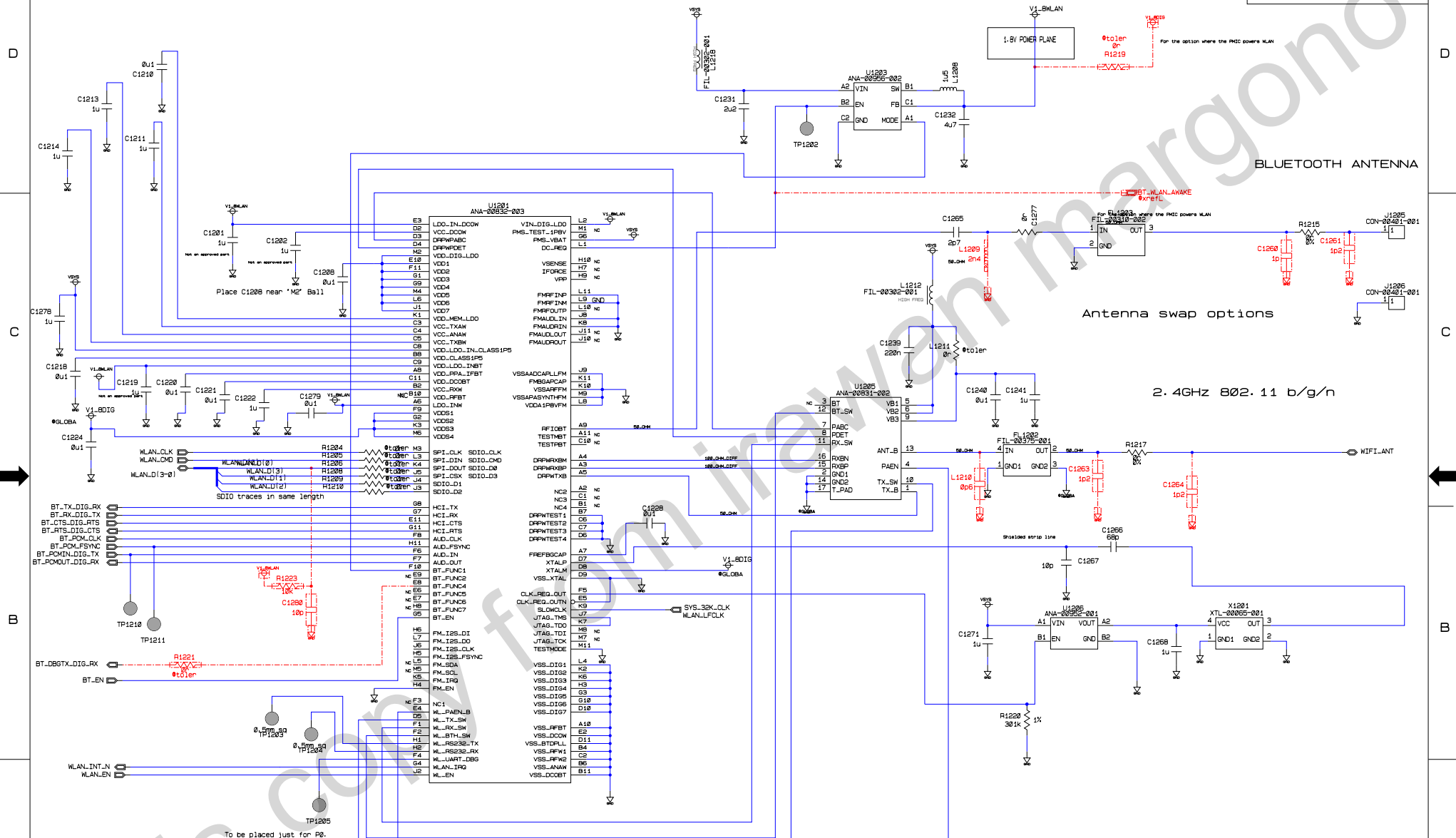

RESEARCH IN MOTION CONFIDENTIAL

HIERARCHICAL BLOCK	COPYRIGHT 2010 RESEARCH IN MOTION LIMITED 295 PHILIP ST. WATERLOO, ONTARIO CANADA PHONE (519) 888-7465, FAX (519) 888-6906
DRAWN BY F10r1da RDC	TITLE R011 Main PCB Schematic
RWD CHECK F10r1da RDC	Uses PCB-29964-009
MFG CHECK UNKNOWN	
EDITED BY: jjacob	SIZE DRAWING No. SCH-29965-009
LAST EDIT: 2010/11/25 14:05:34	REV 6 SHEET 12 of 19

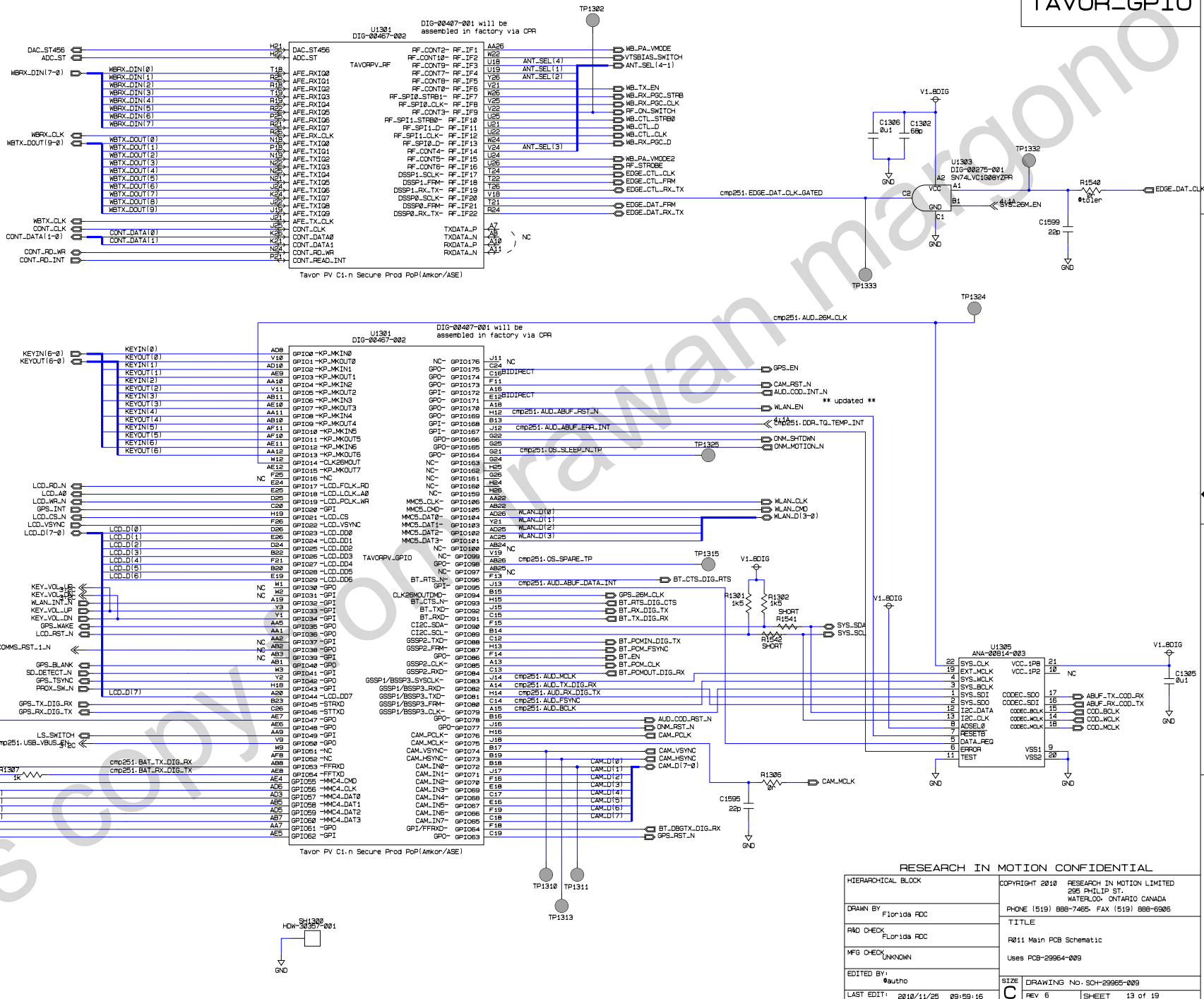

RESEARCH IN MOTION CONFIDENTIAL	
HIERARCHICAL_BLOCK	COPYRIGHT 2010 RESEARCH IN MOTION LIMITED 295 PHILLIP ST. WATERLOO, ONTARIO CANADA
DRAWN BY	F1or1da FDC
PHONE	(519) 889-7465 FAX (519) 889-6986
RWD CHECK	F1or1da FDC
TITLE	R#11 Main PCB Schematic
MFG CHECK	UNKNOWN
Uses PCB	29964-009
EDITED BY:	0autho
SIZE	DRAWING No. SCH-29965-009
LAST EDIT:	2010/11/25 09:59:16
REV	6
SHEET	13 of 19

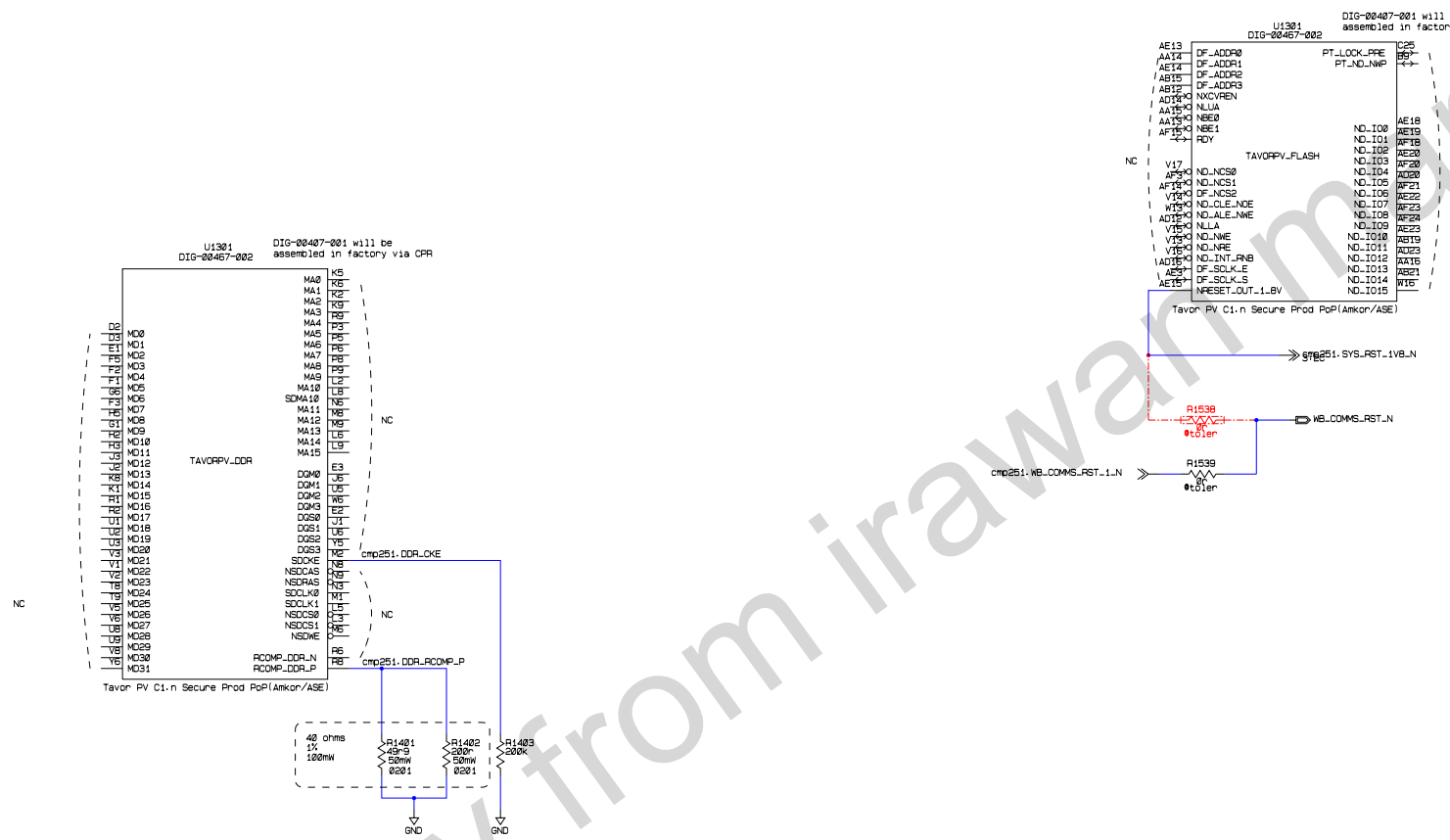

U1301 DIG-02407-021 will be assembled in factory via CPR
DIG-02467-002

U1301 DIG-02407-021 will be assembled in factory via CPR
DIG-02467-002

U1401 PRG-31766-022
Stacked Part

Unprogrammed Moonstone 1s STK-02023-022

RESEARCH IN MOTION CONFIDENTIAL

HIERARCHICAL BLOCK	COPYRIGHT 2010 RESEARCH IN MOTION LIMITED 295 PHILIP ST. WATERLOO, ONTARIO CANADA
DRAWN BY F1or1da PDC	PHONE (519) 888-7465 FAX (519) 888-6986
RWD CHECK F1or1da PDC	TITLE R011 Main PCB Schematic
MFG CHECK UNKNOWN	Uses PCB-29964-009
EDITED BY: 0autho	SIZE DRAWING No. SCH-29965-009
LAST EDIT: 2010/11/25 09:59:17	REV 6 SHEET 14 of 19

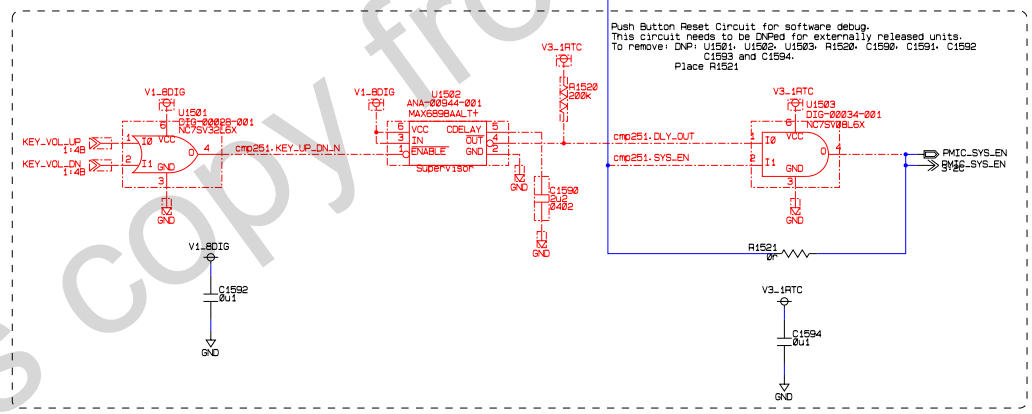
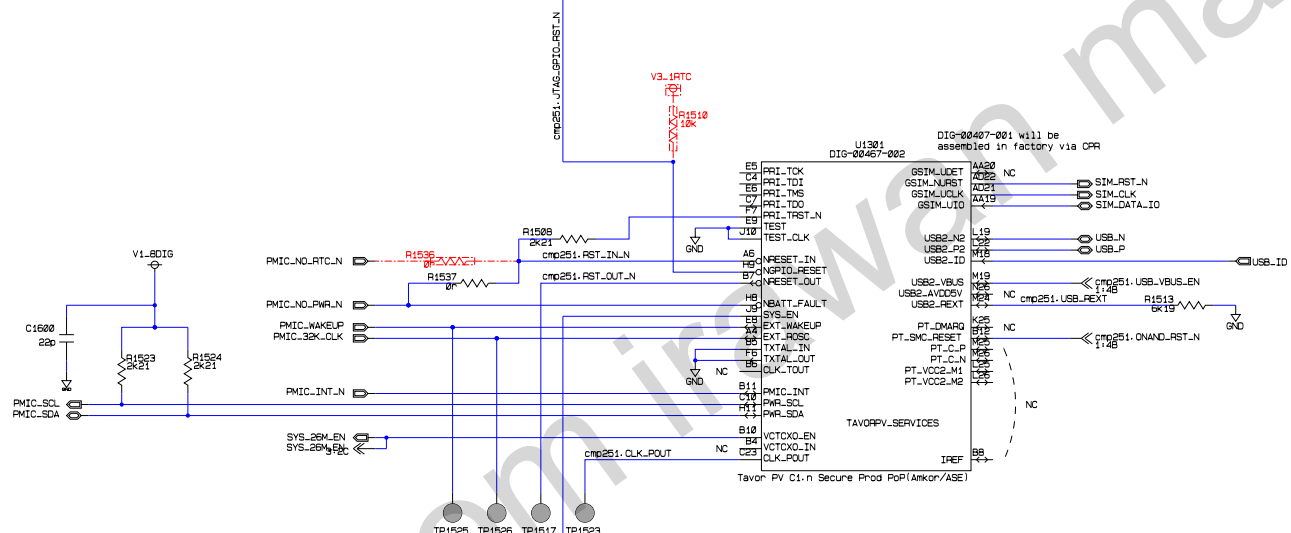
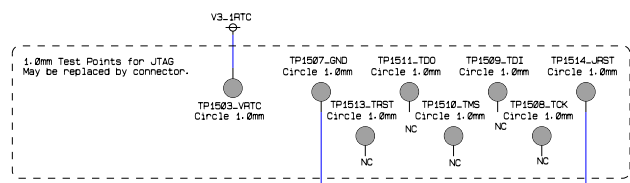

U1381
DIG-00467-002

DIG-00467-001 will be assembled in factory via CPR

E5	PRI_TCK	AA20	NC	SIM_RST_N
E4	PRI_TDI	AA22	NC	SIM_CLK
C7	PRI_TMS	AA19	NC	SIM_DATA_IO
F7	PRI_TDO	AA19	NC	SIM_DATA_IO
F7	PRI_TRST_N	AA19	NC	SIM_DATA_IO
J10	TEST	L19	NC	USB_N
H9	TEST_CLK	M19	NC	USB_P
H9	NRESET_IN	M19	NC	USB_ID
E7	NRESET_OUT	M19	NC	USB_VBUS_EN
H8	BATT_FAULT	M19	NC	USB_VBUS
J5	SYS_EN	M19	NC	USB_REXT
E5	EXT_WAKEUP	M19	NC	USB_REXT_N
E6	EXT_POSC	M19	NC	ONAND_RST_N
B8	XTAL_IN	M19	NC	ONAND_RST_N
F6	XTAL_OUT	M19	NC	ONAND_RST_N
B5	CLK_TOUT	M19	NC	ONAND_RST_N
B11	PMIC_INT	M19	NC	ONAND_RST_N
F11	PWR_SCL	M19	NC	ONAND_RST_N
F11	PWR_SDA	M19	NC	ONAND_RST_N
B10	VCCXO_EN	M19	NC	ONAND_RST_N
B4	VCCXO_IN	M19	NC	ONAND_RST_N
C23	CLK_POUT	M19	NC	ONAND_RST_N

TAVORPV_SERVICES

Tavor PV C1.n Secure Prod PoP(Amkor/ASE)

RESEARCH IN MOTION CONFIDENTIAL

HIERARCHICAL BLOCK	COPYRIGHT 2010 RESEARCH IN MOTION LIMITED 295 PHILIP ST. WATERLOO, ONTARIO CANADA
DRAWN BY F1or1da PDC	PHONE (519) 886-7465 FAX (519) 886-6986
RWD CHECK F1or1da PDC	TITLE R011 Main PCB Schematic
MFG CHECK UNKNOWN	Uses PCB-29964-009
EDITED BY: 0autho	SIZE DRAWING No. SCH-29965-009
LAST EDIT: 2010/11/25 09:59:17	REV 6 SHEET 15 of 19

IO_INTERF2

TRI-COLOR LED

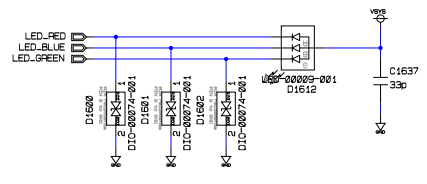

Ambient Light Sensor LIGHT SENSOR

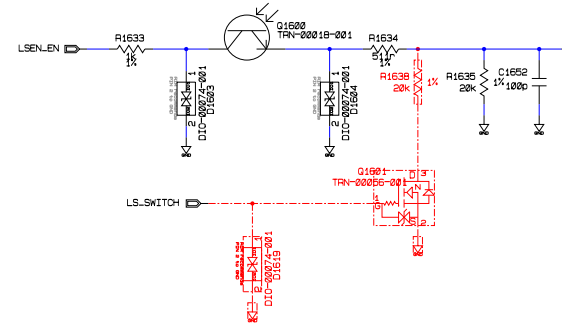

SD Card Connector

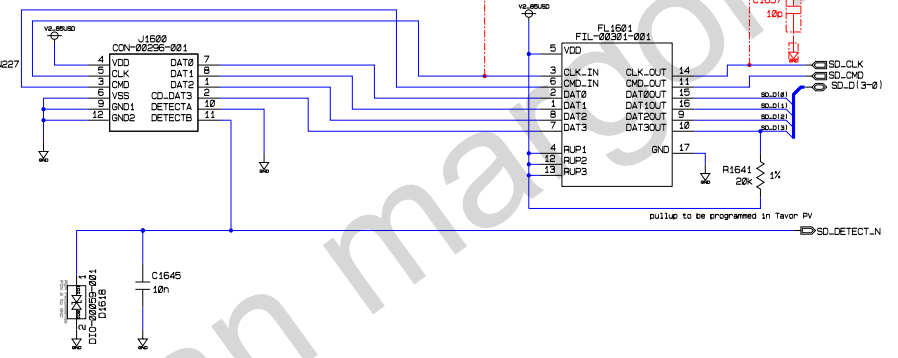

2MP Camera

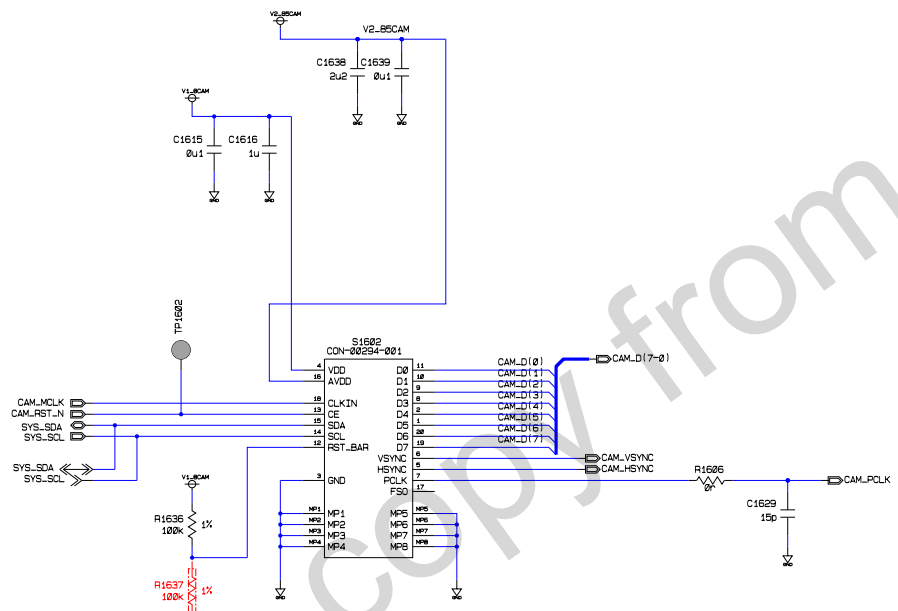

RESEARCH IN MOTION CONFIDENTIAL

HIERARCHICAL BLOCK	COPYRIGHT 2010 RESEARCH IN MOTION LIMITED 295 PHILIP ST. WATERLOO, ONTARIO CANADA
DRAWN BY: F1or1da RDC	PHONE (519) 888-7465 FAX (519) 888-6986
R&D CHECK: F1or1da RDC	TITLE
MFG CHECK: UNKNOWN	R011 Main PCB Schematic
EDITED BY: @autho	Uses PCB-29964-009
LAST EDIT: 2010/11/25 09:59:16	SIZE: DRAWING No. SCH-29965-009
	REV 6 SHEET 16 of 19

TAVOR_POW

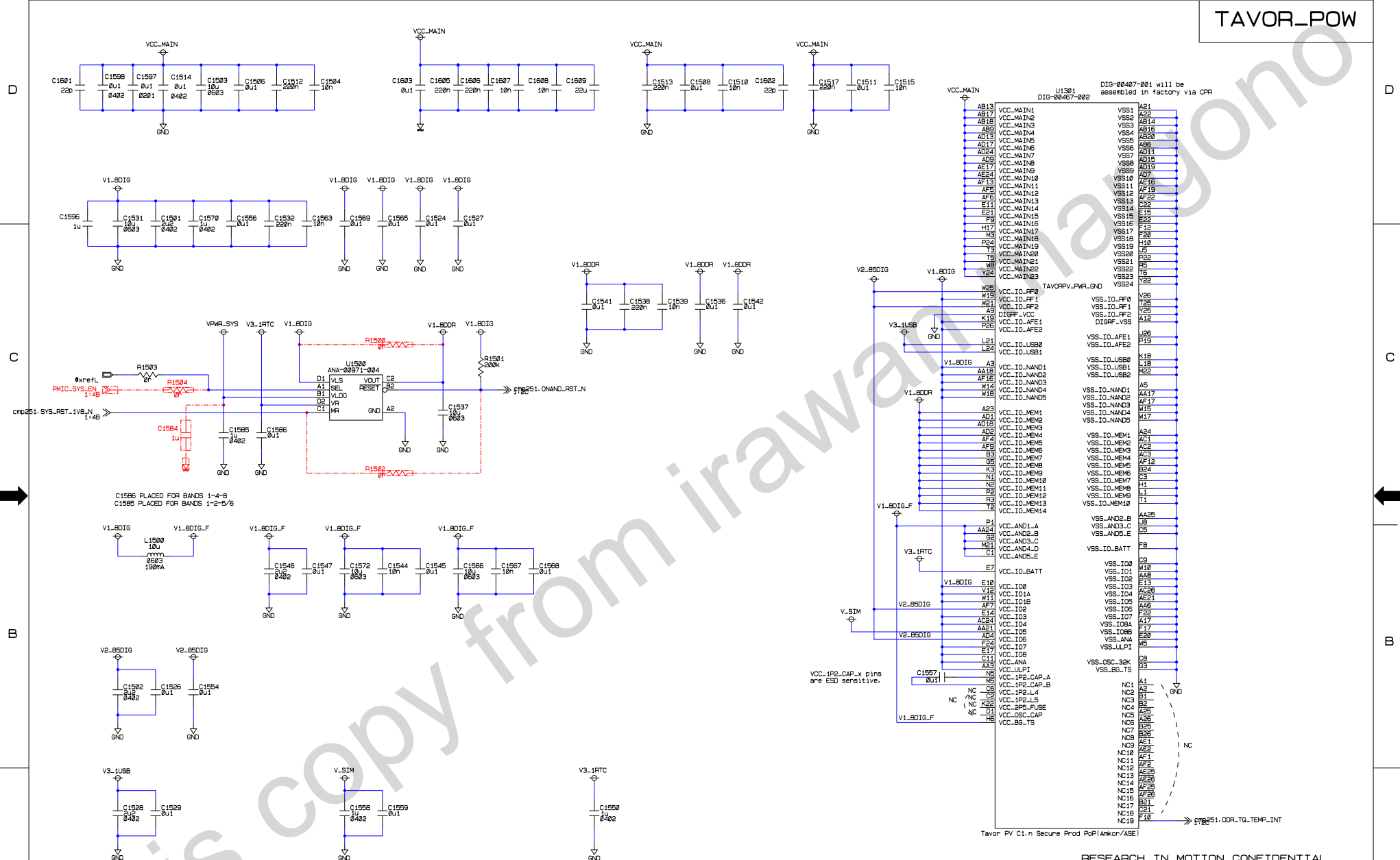

RESEARCH IN MOTION CONFIDENTIAL

HIERARCHICAL BLOCK	COPYRIGHT 2010 RESEARCH IN MOTION LIMITED 295 PHILLIP ST. WATERLOO, ONTARIO CANADA PHONE (519) 886-7465, FAX (519) 886-6986
DRAWN BY FLor:ida PDC	TITLE R011 Main PCB Schematic
RWD CHECK FLor:ida PDC	Uses PCB-29964-009
MFG CHECK UNKNOWN	
EDITED BY maflones	SIZE DRAWING No. SCH-29965-009
LAST EDIT: 2010/11/25 09:59:17	REV 6 SHEET 17 of 19

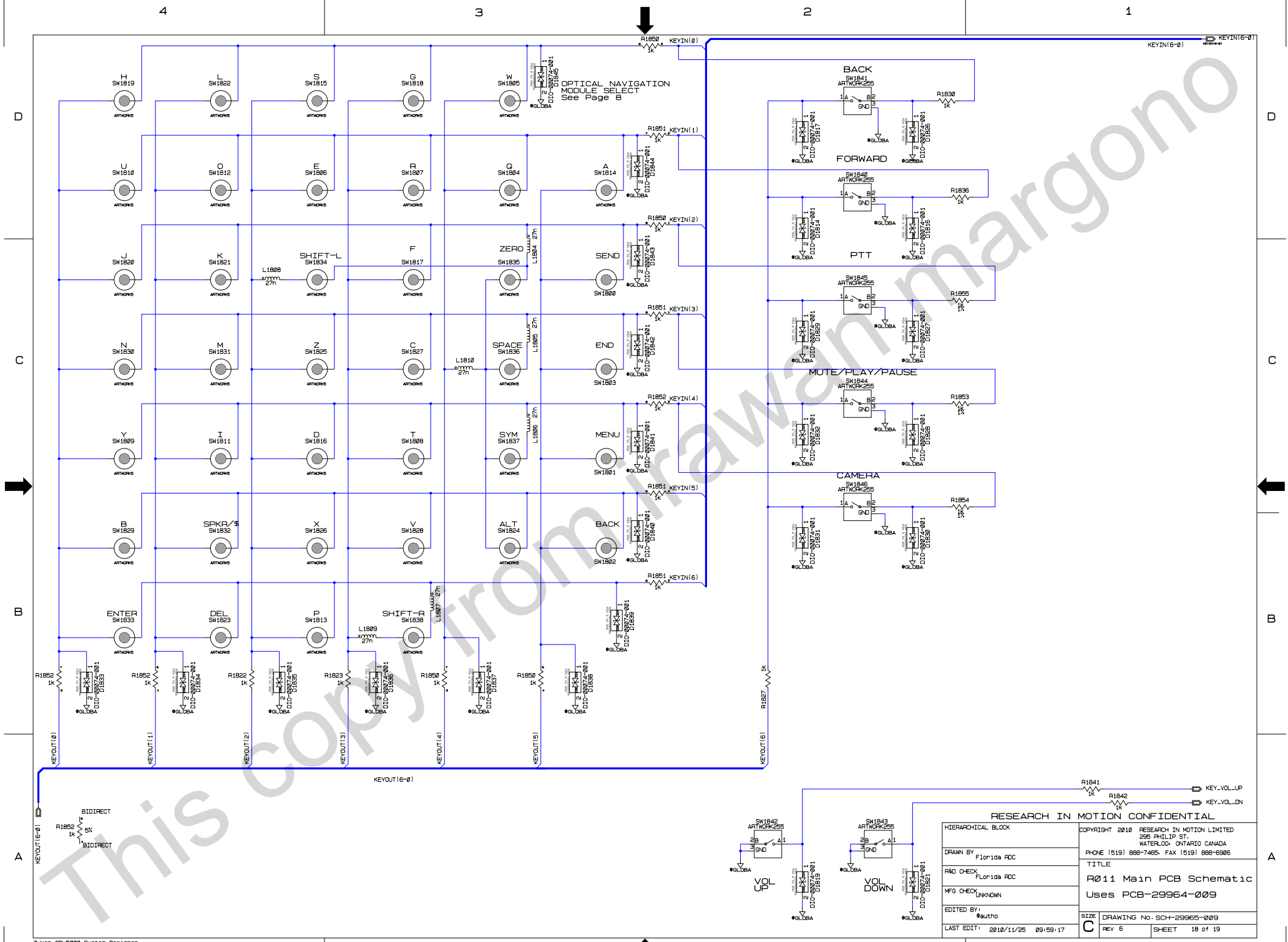

RESEARCH IN MOTION CONFIDENTIAL	
HIERARCHICAL BLOCK	COPYRIGHT 2010 RESEARCH IN MOTION LIMITED 295 PHILIP ST. WATERLOO, ONTARIO CANADA PHONE (519) 889-7465, FAX (519) 888-6906
DRAWN BY F1or1da PDC	TITLE R011 Main PCB Schematic Uses PCB-29964-009
RAD CHECK F1or1da PDC	SIZE DRAWING No. SCH-29965-009
MFG CHECK UNKNOWN	REV 6 SHEET 18 of 19
EDITED BY: aoutho	LAST EDIT: 2010/11/25 09:59:17

D

D

C

C

B

B

A

A

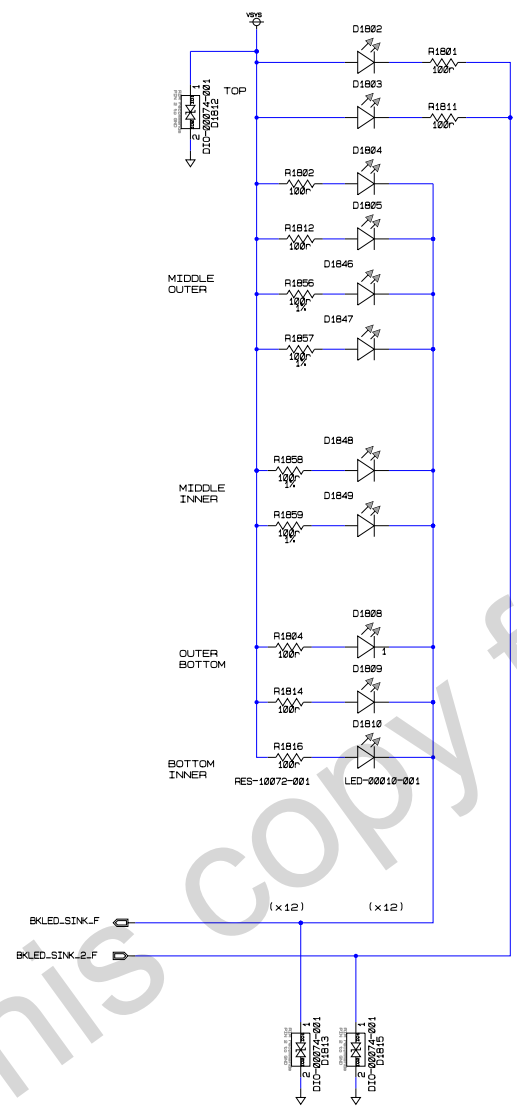

RESEARCH IN MOTION CONFIDENTIAL

HIERARCHICAL BLOCK	COPYRIGHT 2010 RESEARCH IN MOTION LIMITED 295 PHILIP ST. WATERLOO, ONTARIO CANADA
DRAWN BY F1or1da RDC	PHONE (519) 888-7465 FAX (519) 888-6986
R&D CHECK F1or1da RDC	TITLE R011 Main PCB Schematic
MFG CHECK UNKNOWN	Uses PCB-29964-009
EDITED BY: maflores	SIZE DRAWING No. SCH-29965-009
LAST EDIT: 2010/11/25 09:59:17	REV 6 SHEET 19 of 19