

D

D

C

C

B

B

A

A

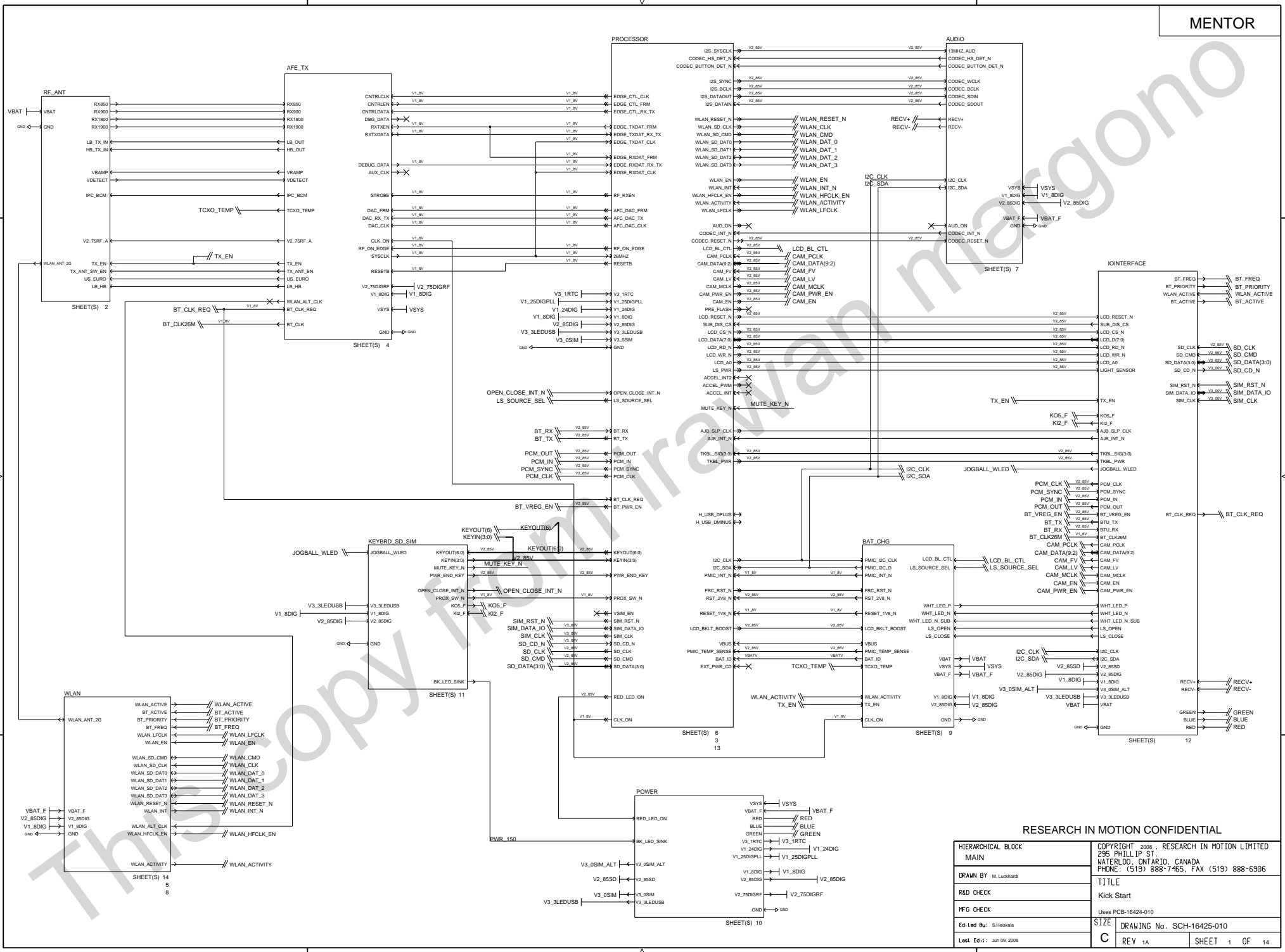

RESEARCH IN MOTION CONFIDENTIAL

HIERARCHICAL BLOCK		COPYRIGHT 2008, RESEARCH IN MOTION LIMITED	
MAIN		295 PHILLIP ST.	
DRAWN BY M. Luckhard		WATERLOO, ONTARIO, CANADA	
R&D CHECK		PHONE: (519) 888-7465, FAX (519) 888-6306	
IFG CHECK		TITLE	
Edi Led Bu: S.Heskala		Kick Start	
Lest: Ed1: Jun 09, 2008		Uses PCB-16424-010	
SIZE		DRAWING No. SCH-16425-010	
C		REV 1A	
		SHEET 1 OF 14	

U401
MM5600R2

A3	GND1	GND37	F8
A7	GND2	GND38	F7
A8	GND3	GND39	F6
A10	GND4	GND40	F5
A11	GND5	GND41	G4
B11	GND6	GND42	G5
B10	GND7	GND43	G6
B8	GND8	GND44	G8
B7	GND9	GND45	G9
C4	GND10	GND46	G8
C6	GND11	GND47	G9
GND12	GND48	H11	
C7	GND13	GND49	H9
C8	GND14	GND50	H8
C11	GND15	GND51	H8
C12	GND16	GND52	H7
D11	GND18	GND54	H6
D9	GND19	GND55	H4
D8	GND20	GND56	J6
D6	GND21	GND57	J11
D5	GND22	GND58	J10
D5	GND23	GND59	J12
E4	GND24	GND60	K11
E4	GND25	GND61	K10
E5	GND26	GND62	K7
E6	GND27	GND63	K8
E7	GND28	GND64	K7
E8	GND29	GND65	K2
E9	GND30	GND66	L6
E10	GND31	GND67	L4
E11	GND32	GND68	L5
F12	GND33	GND69	L7
F11	GND34	GND70	L9
F10	GND35	GND71	L11
F9	GND36	GND72	

ANA-0021-001|259x0.8_1.4ht_010502_04

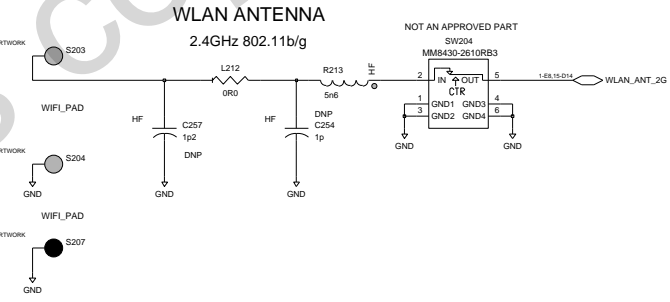
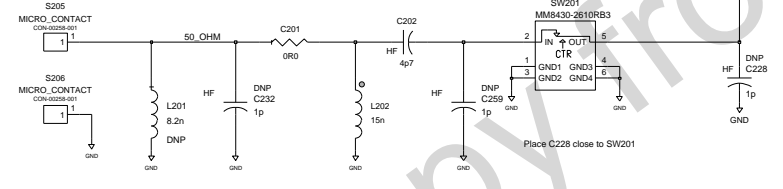
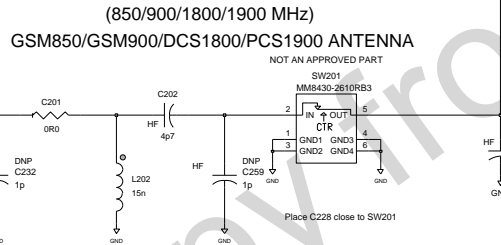
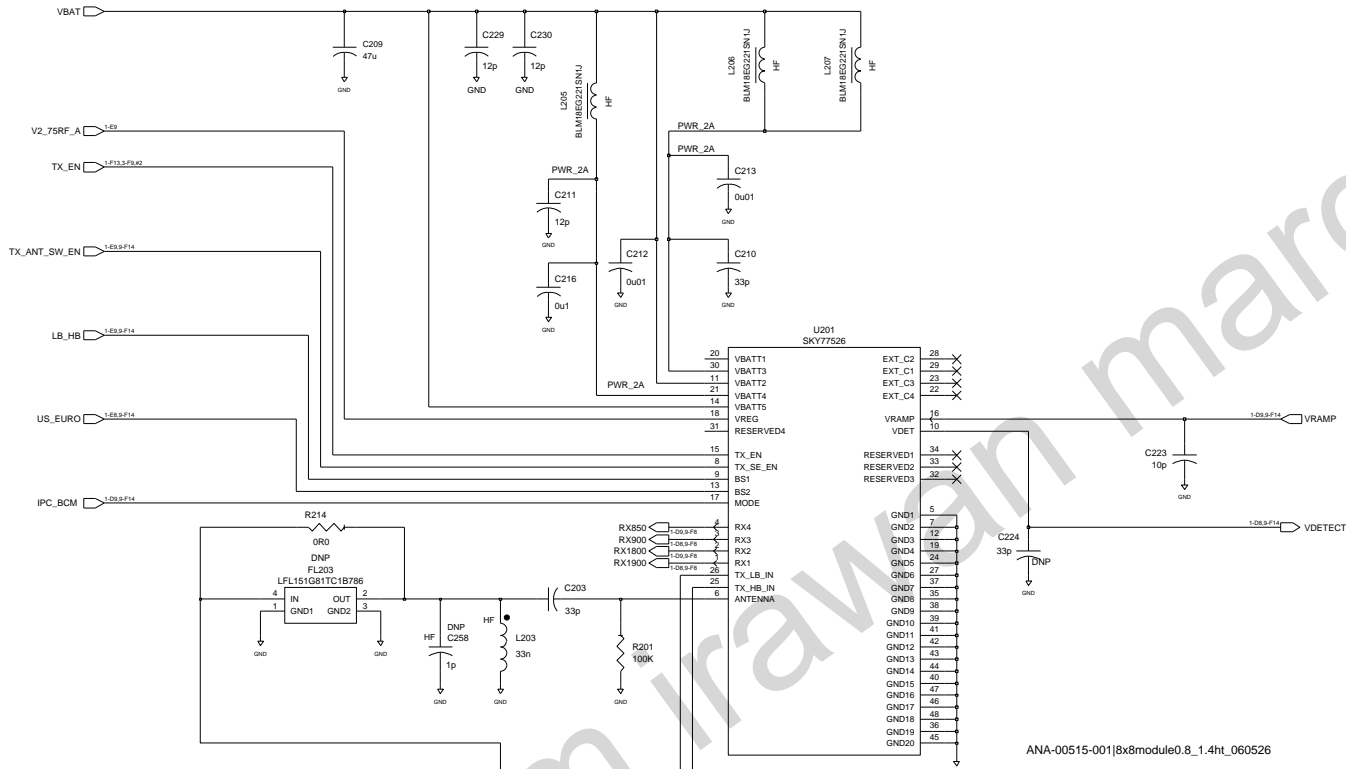

RESEARCH IN MOTION CONFIDENTIAL

HIERARCHICAL BLOCK RF_ANT	COPYRIGHT 2008, RESEARCH IN MOTION LIMITED 295 PHILLIP ST. WATERLOO, ONTARIO, CANADA PHONE: (519) 888-7465, FAX (519) 888-6306
DRAWN BY M. Luckhardt	TITLE Kick Start
R&D CHECK	Uses PCB-16424-010
HFQ CHECK	SIZE
Edi Led By: S.Heskala	DRAWING No. SCH-16425-010
Level Ed1: Jun 09, 2008	C REV 1A SHEET 2 OF 14

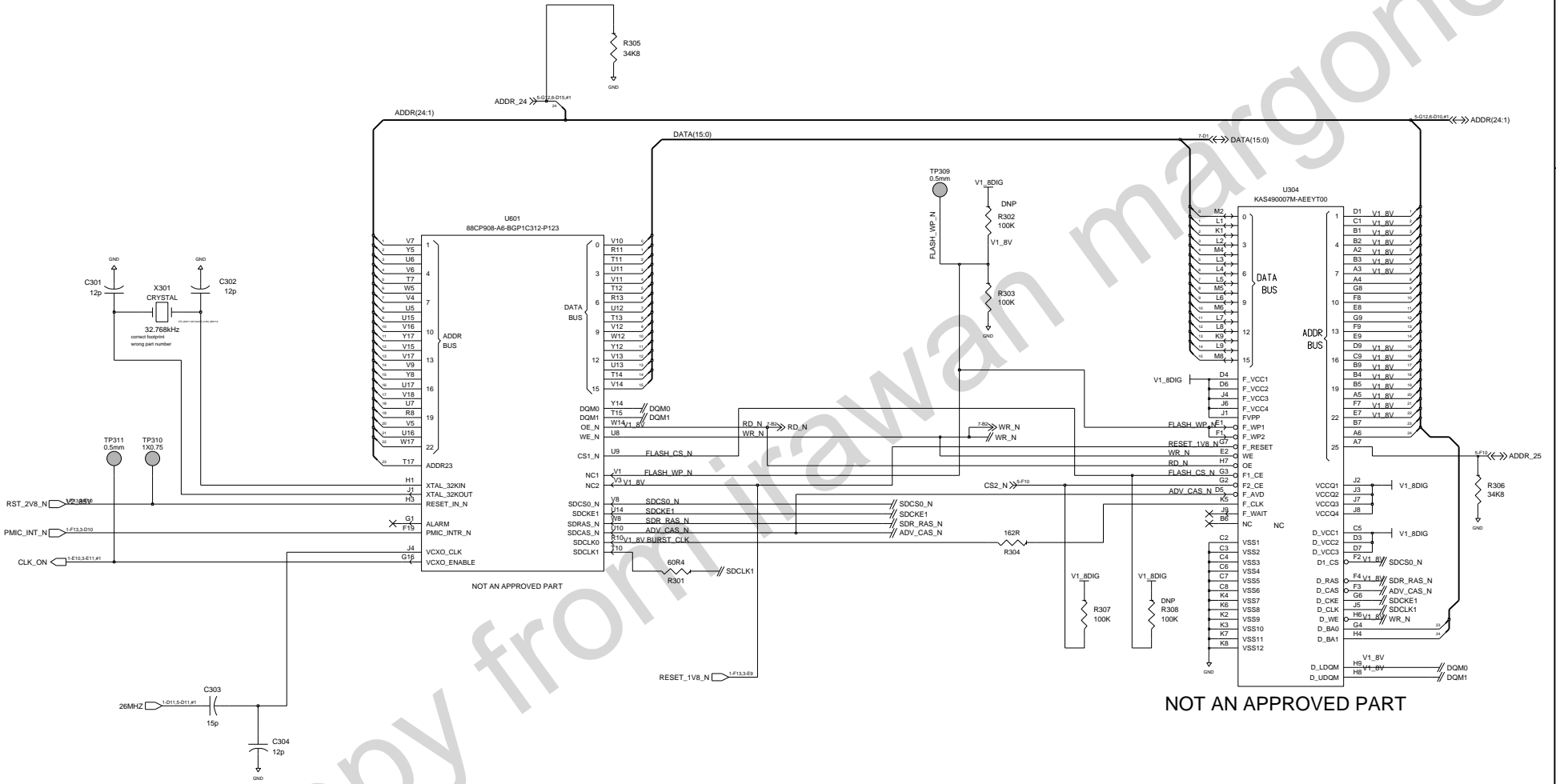

This copy from Irawan margono

NOT AN APPROVED PART

RESEARCH IN MOTION CONFIDENTIAL

HIERARCHICAL BLOCK PROCESSOR_I2		COPYRIGHT 2008, RESEARCH IN MOTION LIMITED 295 PHILLIP ST. WATERLOO, ONTARIO, CANADA PHONE: (519) 888-7465, FAX (519) 888-6306	
DRAWN BY: M. Luckhardt		TITLE Kick Start	
R&D CHECK		Uses PCB-16424-010	
MFG CHECK		SIZE DRAWING No. SCH-16425-010	
Edi Led By: S.Hestala		C REV 1A SHEET 3 OF 14	
Level Ed1: Jun 09, 2008			

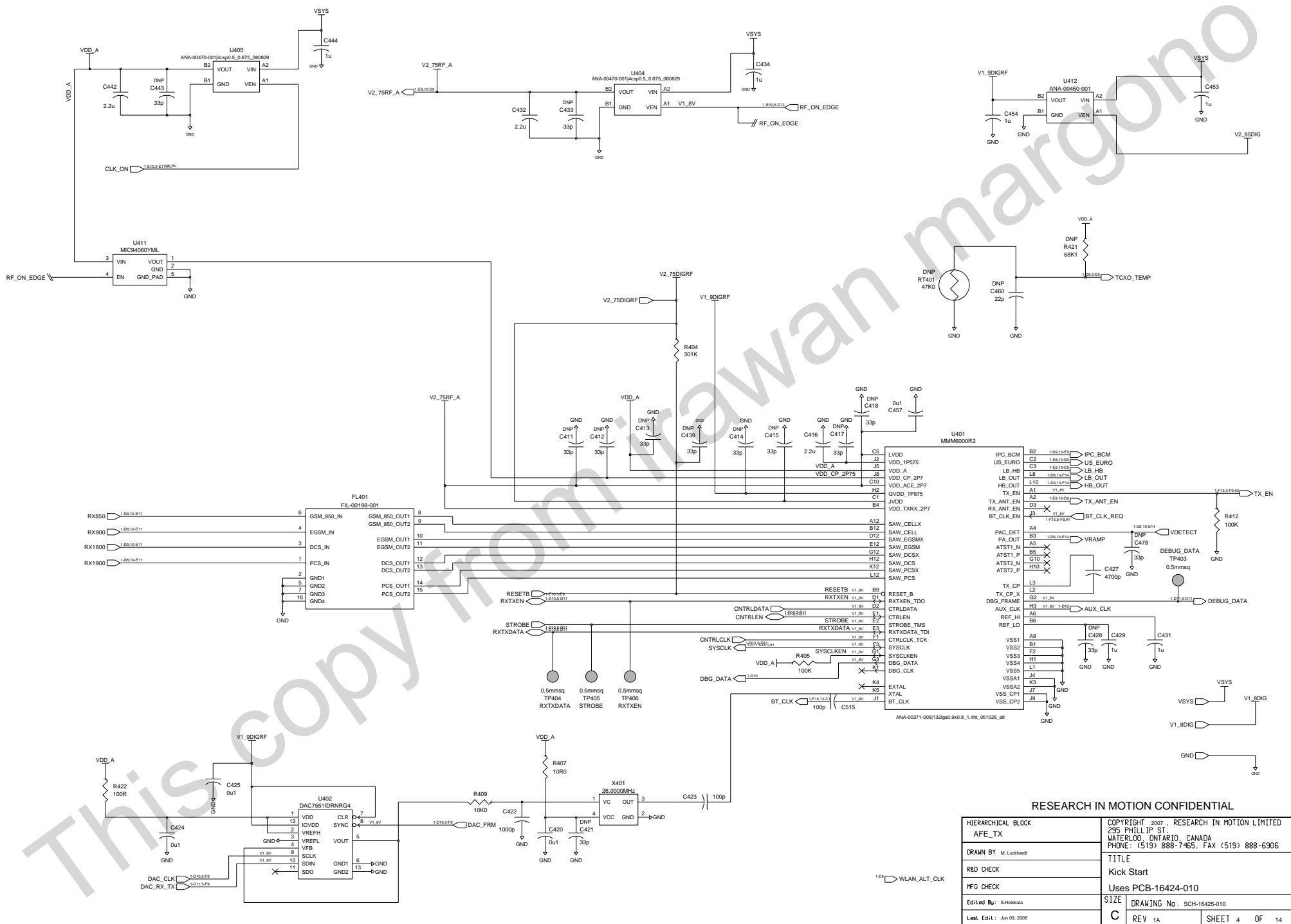

RESEARCH IN MOTION CONFIDENTIAL

HIERARCHICAL BLOCK AFE_TX	COPYRIGHT 2007, RESEARCH IN MOTION LIMITED 295 PHILLIP ST. WATERLOO, ONTARIO, CANADA PHONE: (519) 888-7465, FAX (519) 888-6306
DRAWN BY: M. Luckhardt	TITLE Kick Start
R&D CHECK	Uses PCB-16424-010
RFG CHECK	SIZE DRAWING No. SCH-16425-010
Edi Led Bu: S.Hestala	C REV 1A SHEET 4 OF 14
Level Ed14: Jun 09, 2008	

4

3

2

1

MENTOR

D

D

C

C

B

B

A

A

This copy from irawan margono

RESEARCH IN MOTION CONFIDENTIAL

HIERARCHICAL BLOCK WLAN2		COPYRIGHT 2008, RESEARCH IN MOTION LIMITED 295 PHILLIP ST. WATERLOO, ONTARIO, CANADA PHONE: (519) 888-7465, FAX (519) 888-6306	
DRAWN BY: M. Luckhardt		TITLE Kick Start	
R&D CHECK		Uses PCB-16424-010	
MFG CHECK		DRAWING No. SCH-16425-010	
Edi Led By: mukhar		SIZE C	REV 1A SHEET 5 OF 14
Level: Ed14: Jan 7, 2008, 2:19:03 pm			

4

3

2

1

D

C

B

A

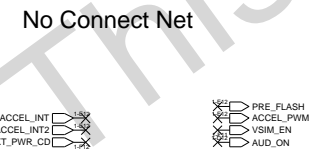
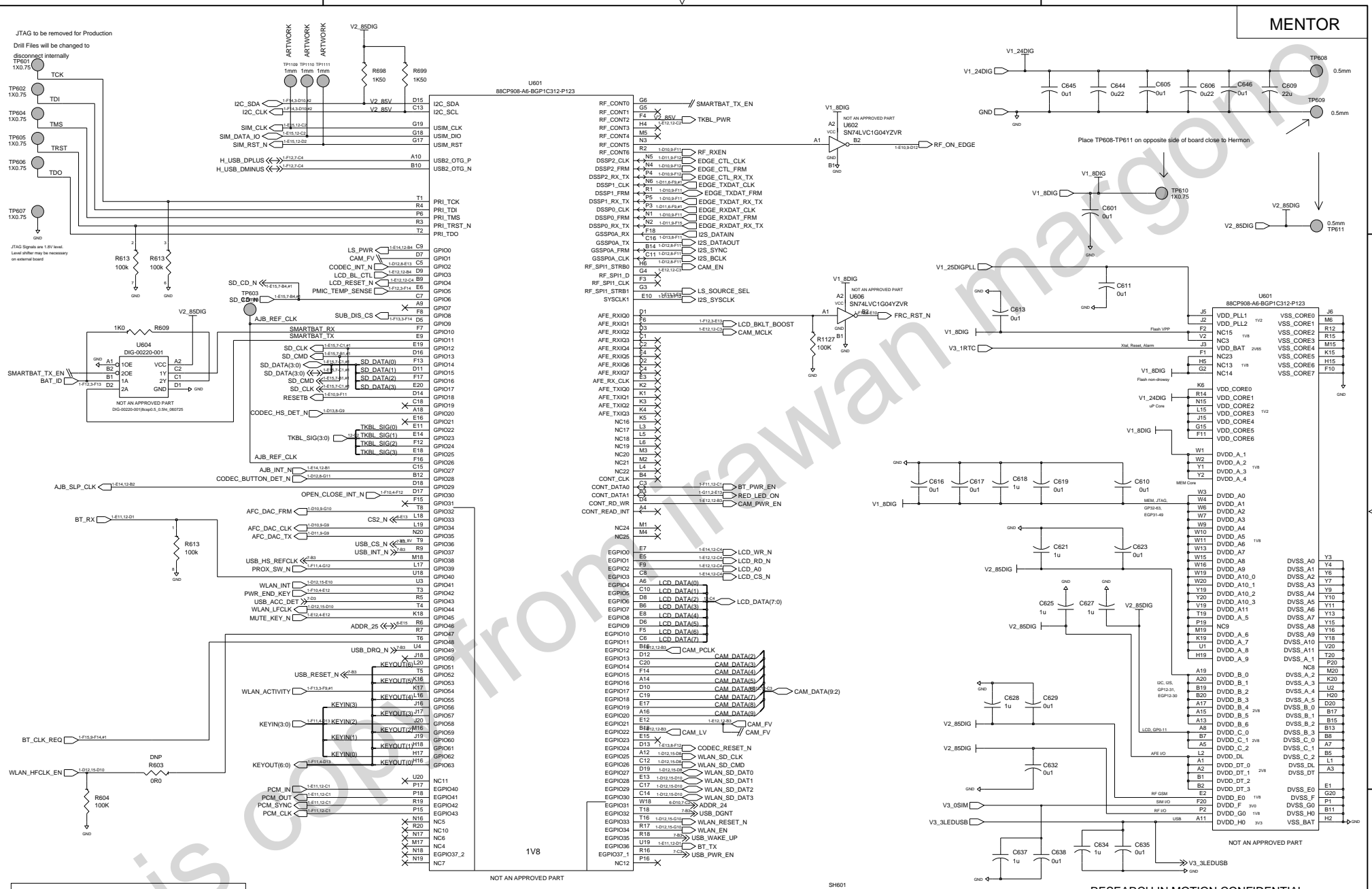

HIERARCHICAL BLOCK PROCESSOR	COPYRIGHT 2008, RESEARCH IN MOTION LIMITED 295 PHILLIP ST. WATERLOO, ONTARIO, CANADA PHONE: (519) 888-7465, FAX (519) 888-6306
DRAWN BY M. Luckhardt	
R&D CHECK	TITLE Kick Start
IFG CHECK	Uses PCB-16424-010
Edi Led By: S.Heskala	SIZE DRAWING No. SCH-16425-010
Label Ed1: Jun 09, 2008	C REV 1A SHEET 6 OF 14

D

D

C

C

B

B

A

A

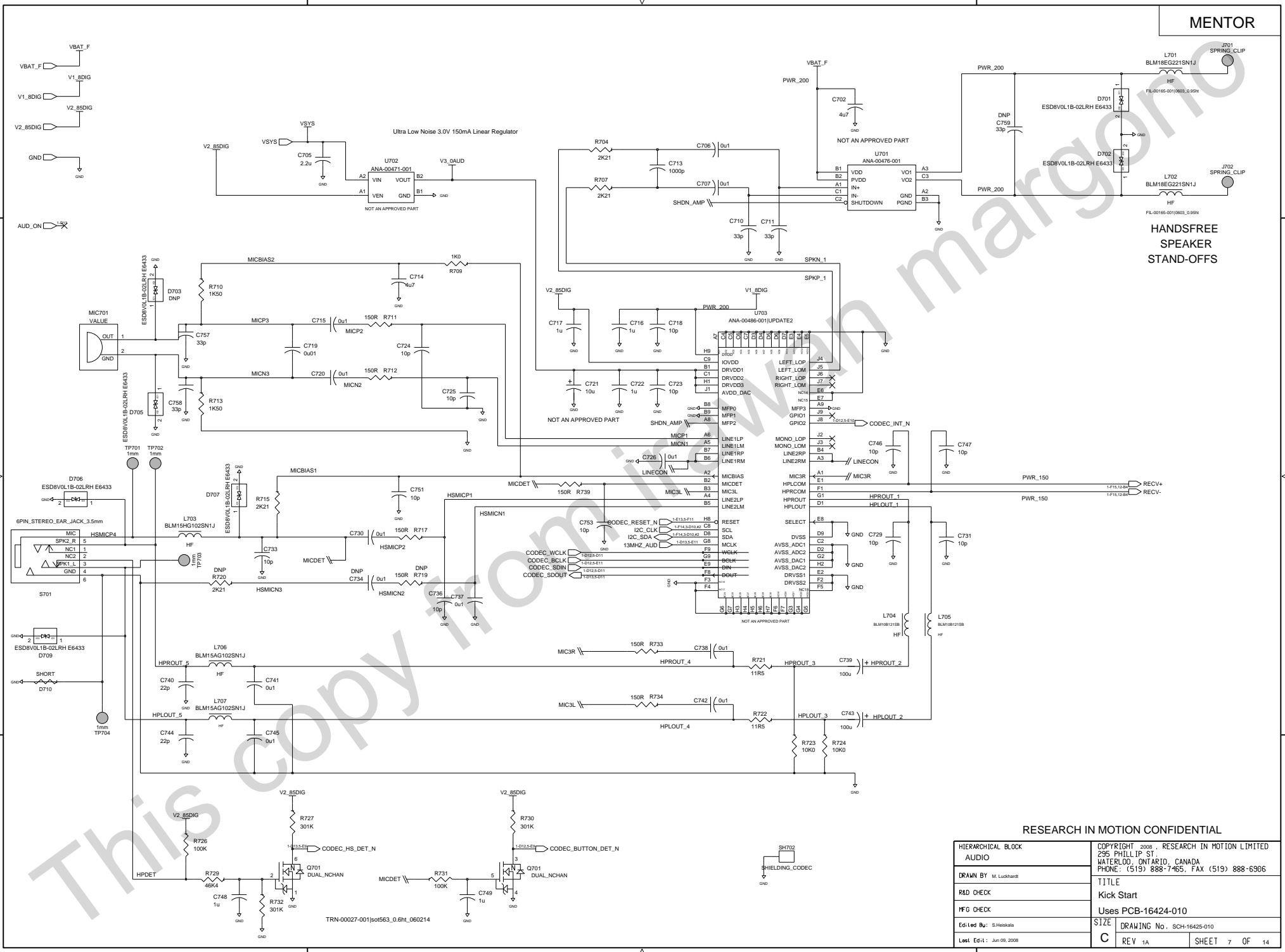

HANDSFREE
SPEAKER
STAND-OFFS

RESEARCH IN MOTION CONFIDENTIAL

HIERARCHICAL BLOCK AUDIO		COPYRIGHT 2008, RESEARCH IN MOTION LIMITED 295 PHILLIP ST. WATERLOO, ONTARIO, CANADA PHONE: (519) 888-7465, FAX (519) 888-6306	
DRAWN BY: M. Luckhardt		TITLE Kick Start	
R&D CHECK		Uses PCB-16424-010	
MFG CHECK		SIZE DRAWING No. SCH-16425-010	
Ed: Led Bu: S.Heskala		C REV 1A SHEET 7 OF 14	
Lobl Ed: 1 Jun 09, 2008			

4

3

2

1

MENTOR

D

D

C

C

B

B

A

A

This copy from irawan margono

RESEARCH IN MOTION CONFIDENTIAL

HIERARCHICAL BLOCK WLAN3		COPYRIGHT 2008, RESEARCH IN MOTION LIMITED 295 PHILLIP ST. WATERLOO, ONTARIO, CANADA PHONE: (519) 888-7465, FAX (519) 888-6306	
DRAWN BY: M. Luckhard		TITLE Kick Start	
R&D CHECK		Uses PCB-16424-010	
MFG CHECK		SIZE	DRAWING No. SCH-16425-010
Edi Led By: mukhar		C	REV 1A
Level: Ed14: Jan 7, 2008, 2:19:54 pm			SHEET 8 OF 14

4

3

2

1

4

3

2

1

D

D

C

C

B

B

A

A

4

3

2

1

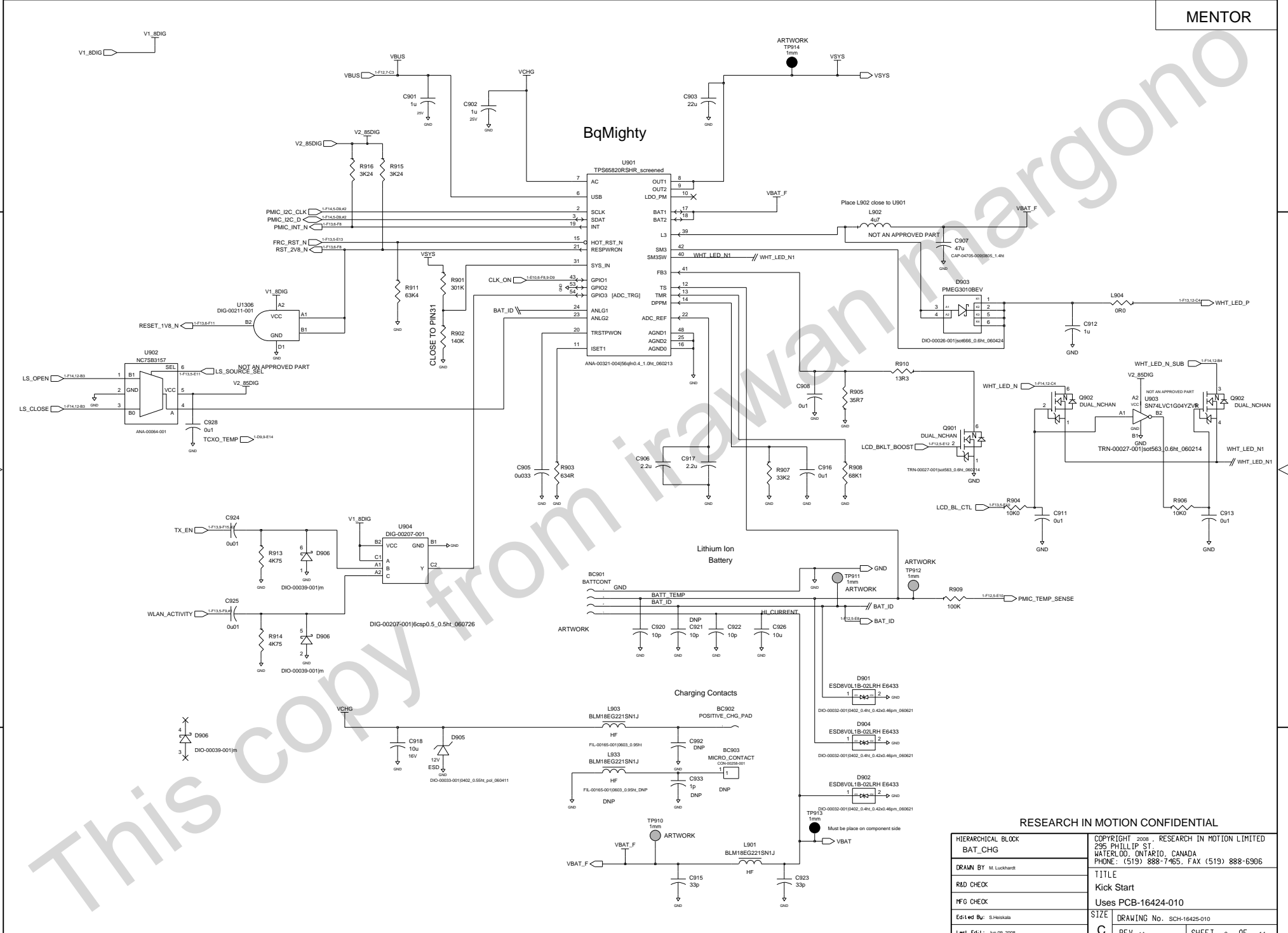

RESEARCH IN MOTION CONFIDENTIAL

HIERARCHICAL BLOCK BAT_CHG	COPYRIGHT 2008, RESEARCH IN MOTION LIMITED 295 PHILLIP ST WATERLOO, ONTARIO, CANADA PHONE: (519) 888-7465, FAX (519) 888-6906
DRAWN BY M. Luchardt	TITLE Kick Start
R&D CHECK	Uses PCB-16424-010
MFG CHECK	SIZE DRAWING No. SCH-16425-010
Edited by: S. Haskala	C REV 1A SHEET 9 OF 14
Last Edt1: Jun 09, 2008	

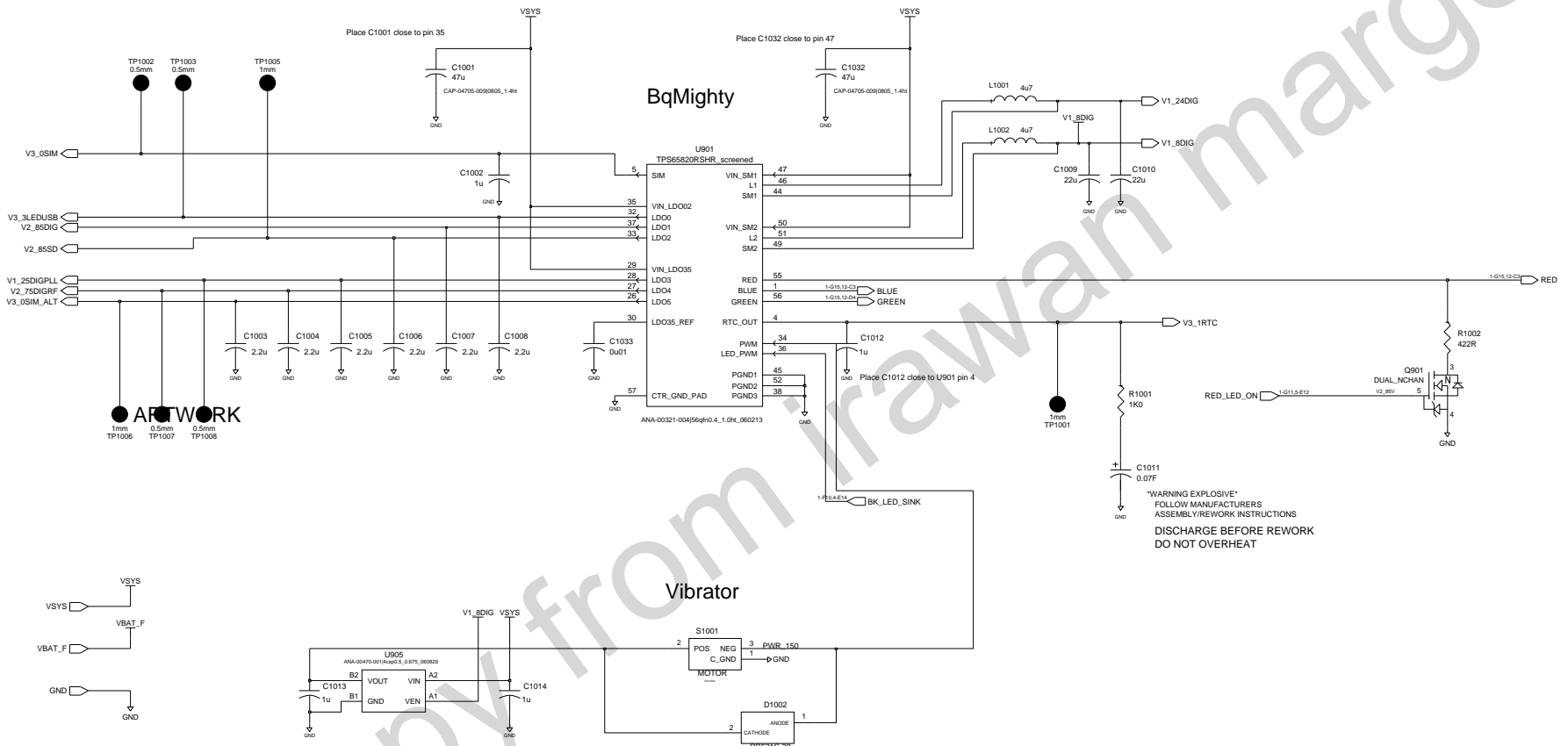

RESEARCH IN MOTION CONFIDENTIAL

HIERARCHICAL BLOCK POWER		COPYRIGHT 2008, RESEARCH IN MOTION LIMITED 295 PHILLIP ST. WATERLOO, ONTARIO, CANADA PHONE: (519) 888-7465, FAX (519) 888-6306	
DRAWN BY: M. Luckhardt		TITLE Kick Start	
R&D CHECK		Uses PCB-16424-010	
MFG CHECK		SIZE	
Edi Led Bu: S.Heskala		DRAWING No. SCH-16425-010	
Level Ed1: Jun 09, 2008		C REV 1A SHEET 10 OF 14	

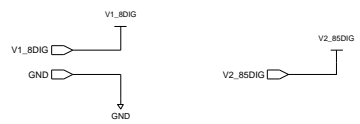
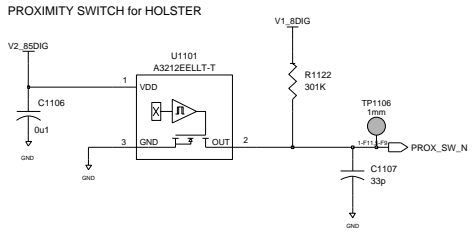
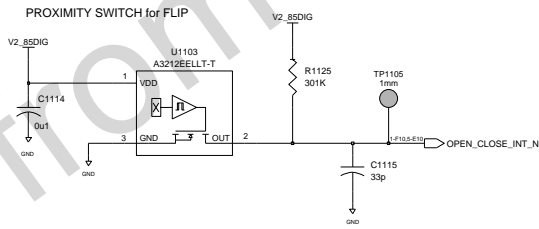
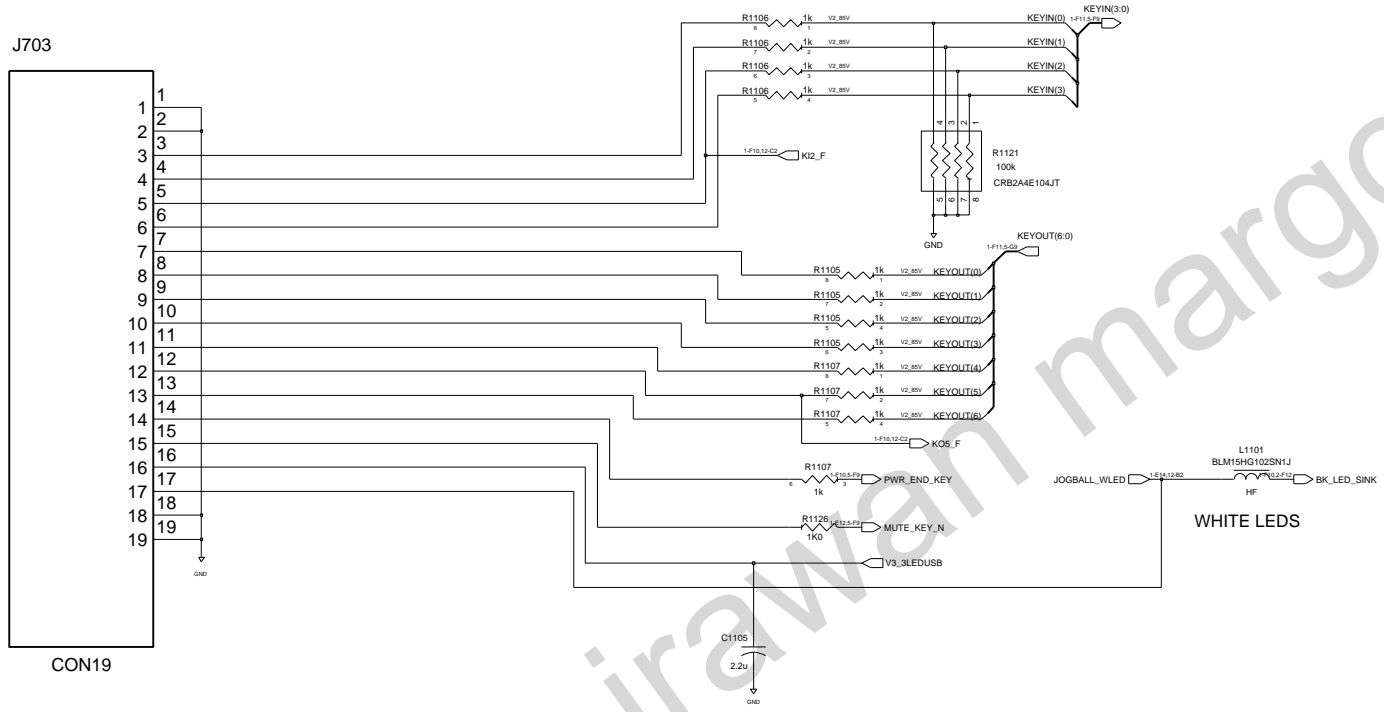

RESEARCH IN MOTION CONFIDENTIAL

HIERARCHICAL BLOCK KEYBRD_SD_SIM		COPYRIGHT 2008, RESEARCH IN MOTION LIMITED 295 PHILLIP ST. WATERLOO, ONTARIO, CANADA PHONE: (519) 888-7465, FAX (519) 888-6306	
DRAWN BY: M. Luckhardt		TITLE Kick Start	
R&D CHECK		Uses PCB-16424-010	
MFG CHECK		SIZE	
Edi Led Bu: S.Heskala		DRAWING No. SCH-16425-010	
Level Edi L: Jun 09, 2008		C REV 1A SHEET 11 OF 14	

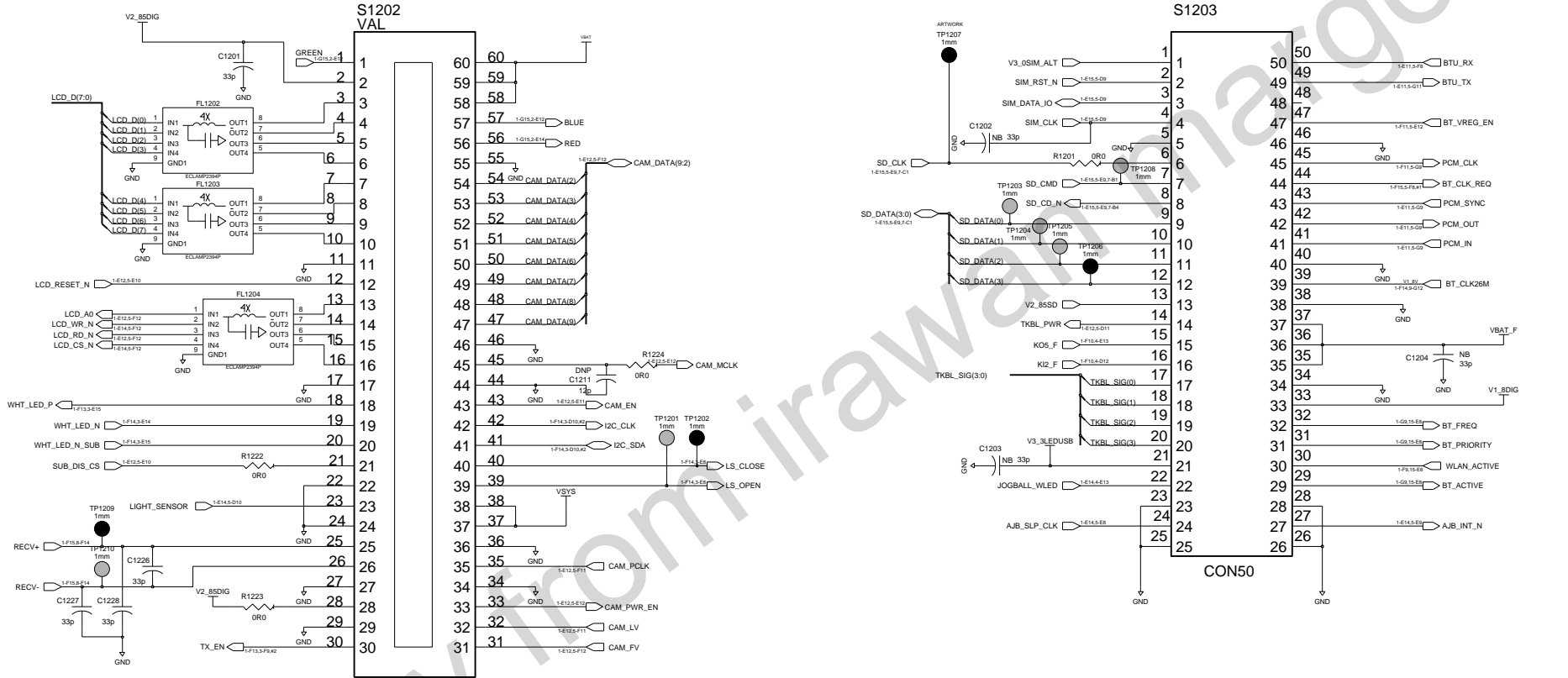

RESEARCH IN MOTION CONFIDENTIAL

HIERARCHICAL BLOCK JOINTERFACE2		COPYRIGHT 2008, RESEARCH IN MOTION LIMITED 295 PHILLIP ST. WATERLOO, ONTARIO, CANADA PHONE: (519) 888-7465, FAX (519) 888-6306	
DRAWN BY: M. Luckhardt		TITLE Kick Start	
R&D CHECK		Uses PCB-16424-010	
MFG CHECK		SIZE DRAWING No. SCH-16425-010	
Edi Led Bu: S.Hessala		C REV 1A SHEET 12 OF 14	
Level: Ed14: Jun 09, 2008			

HS-USB CONTROLLER

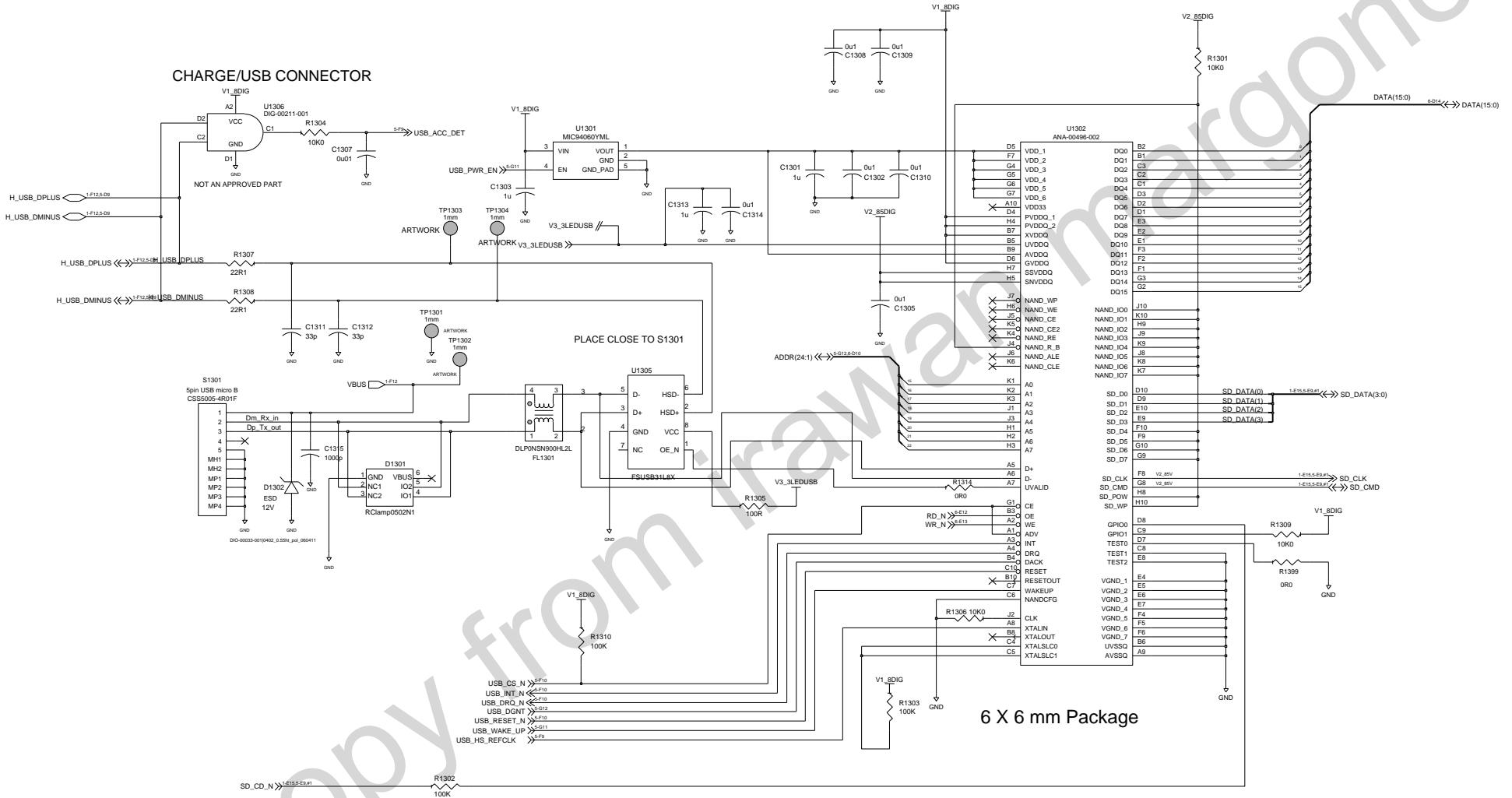

RESEARCH IN MOTION CONFIDENTIAL

HIERARCHICAL BLOCK PROCESSOR_I3		COPYRIGHT 2008, RESEARCH IN MOTION LIMITED 295 PHILLIP ST. WATERLOO, ONTARIO, CANADA PHONE: (519) 888-7465, FAX (519) 888-6306	
DRAWN BY: M. Luckhardt		TITLE Kick Start	
R&D CHECK		Uses PCB-16424-010	
MFG CHECK		SIZE DRAWING No. SCH-16425-010	
Edi Led Bu: S.Hestala		C REV 1A SHEET 13 OF 14	
Level Ed14: Jun 9, 2008			

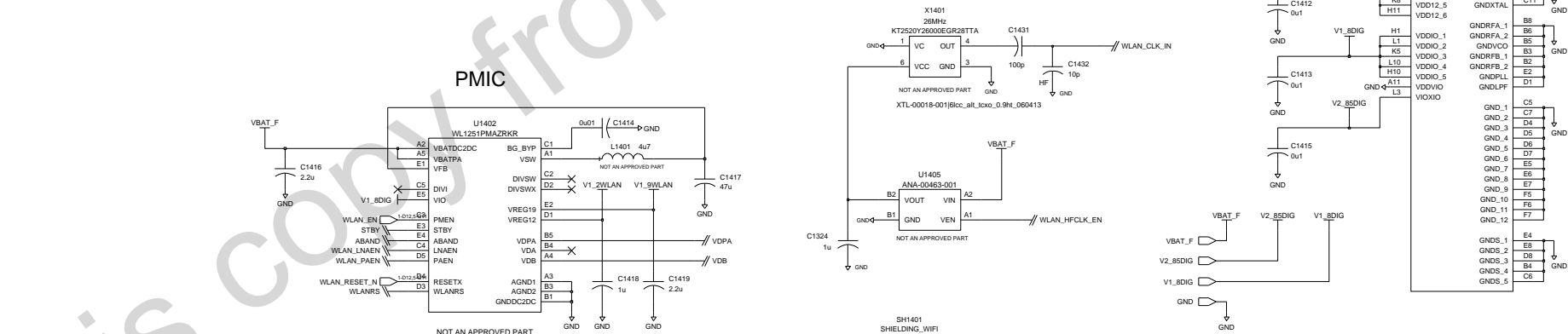
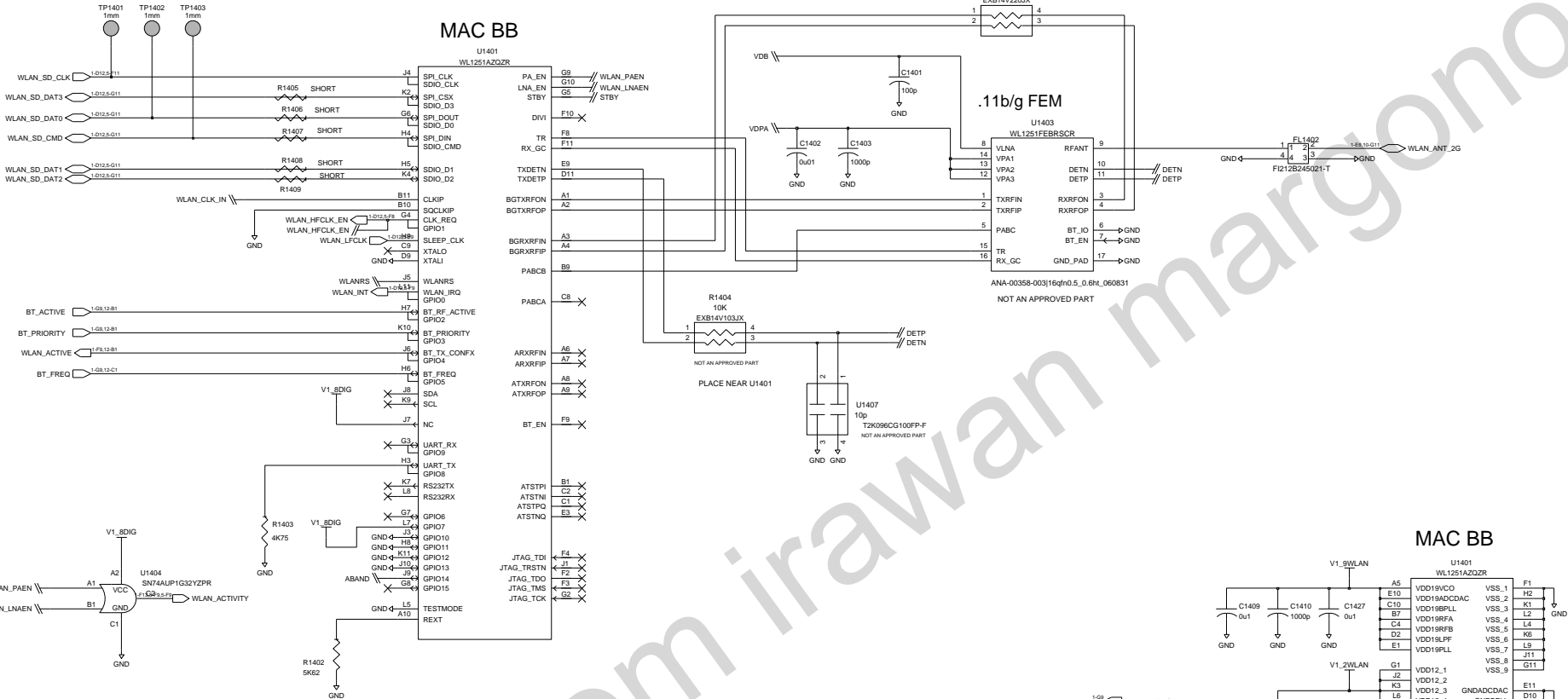

WLAN

HIERARCHICAL BLOCK WLAN		COPYRIGHT 2008, RESEARCH IN MOTION LIMITED 295 PHILLIP ST. WATERLOO, ONTARIO, CANADA PHONE: (519) 888-7465, FAX (519) 888-6306	
DRAWN BY M. Luckhard	R&D CHECK	TITLE Kick Start	
HFG CHECK	Uses PCB-16424-010		
Edi Led Bu: S.Heskala	SIZE DRAWING No. SCH-16425-010		
Level: Ed1:1 Jun 09, 2008	REV 1A		SHEET 14 OF 14